

WP & WPS Series Work Positioners

Installation, Operation and Service Manual

Model Number _____

Serial # _____

Date placed in service _____

**IMPORTANT: READ CAREFULLY
BEFORE INSTALLING OR OPERATING LIFT**

Part orders are subject to a \$50 minimum charge.



This manual was current at the time of printing. To obtain the latest, most updated version, please contact Presto Lifts Customer Service Department or go to our website: www.PrestoLifts.com -- you will find a complete list of current owner's manuals to print.

TABLE OF CONTENTS

SECTION 1:	
Introduction.....	3
SECTION 2:	
Safety	3
SECTION 3:	
Installation.....	3
A. Inspection	3
B. Removing from Pallet	3
SECTION 4:	
Operation.....	4
A. Operating Instructions.....	4
B. Daily Operations Maintenance Checks	4
SECTION 5:	
Maintenance.....	4
A. Instructions.....	4
B. Monthly Operations Maintenance Checks	4
SECTION 6:	
Service.....	5
RESTOCKING POLICY.....	15
RETURN MATERIALS AUTHORIZATION (RMA) PROCEDURES	15
LIMITED WARRANTY.....	20

List of Figures

Figure 1: Model WP.....	7
Figure 2: Model WPS	14
Figure 3: WP & WPS Rear View	15
Figure 4: Steering Assembly	17
Figure 5: Floor Lock Assembly.....	18
Figure 6: Chain Roller Assemblies	19
Figure 7: 1000, 1500 & 2700 lb. Cylinder.....	20
Figure 8: 2000 lb. Capacity Cylinder.....	21
Figure 9: Work Positioner Back Plate Assembly	22
Figure 10: DC Power Wiring Schematic	24
Figure 11: Standard DC Power Pack Illustration.....	25
Figure 12: DC Power Pack With Remote Control Illustration	26
Figure 13: AC Power Wiring Schematic.....	27
Figure 14: Standard AC Power Pack Illustration.....	28
Figure 15: AC Power Pack With Remote Control Illustration.....	29

List of Tables

Table 1: Steering Components	7
Table 2: Cylinder Components	14
Table 3: Replacement Parts.....	15

SECTION 1

INTRODUCTION

This manual attempts to provide all of the information necessary for the safe and proper installation, operation and maintenance of Presto's Battery Operated Work Positioner. It is important that all personnel involved with the installation, maintenance or operation of the Work Positioner read this manual. Additional manuals are available at www.prestolifts.com

The battery-operated Work Positioner is equipped with a data plate that has a serial number and model identification. Please refer to these numbers when ordering parts or requesting further information.

The battery-operated Work Positioner is designed for lifting, lowering and positioning a wide variety of loads. Call Presto for further instructions where unique situations arise that are not covered in this manual.

The battery-operated Work Positioner is designed for only indoor, non-hazardous locations. These units are not for personnel lifting. All equipment is manually propelled and has a hydraulically powered vertical travel.

SECTION 2

SAFETY

The battery-operated Work Positioner is a very powerful lift capable of doing large amounts of work.

Carefully read this manual before installing or operating this lift. Some hazards have been identified that may occur during the installation, maintenance and use of this lift.

WARNING!

- Do not perform any repair work on lifts if there is a load on the forks or platform.
- Do not perform any repair work if the forks or platform is in the raised position.

- All personnel must stand clear of the lift while in motion.
- Do not put hands or feet under the forks or platform.
- Do not stand underneath the forks or platform.
- Do not stand in front of the Work Positioner while in motion.
- Do not stand, sit or climb on the lift.
- Do not use the lift on soft, uneven or unstable surfaces.
- Do not exceed the load center or capacity.

SECTION 3

INSTALLATION

A. INSPECTION

The lift is tested and inspected prior to shipment. Inspect the Work Positioner completely upon receipt, to determine if there is any damage caused during shipment by the freight company and that the lift is complete. A freight claim must be filed with the freight company if damage is apparent. Do Not use the lift if there appears to be any damage. Check the following with the lift in a collapsed position:

- Check for signs of damage especially to the back cabinet that houses the battery, electrical/hydraulic power pack.
- Check all connections for tightness. Is there hydraulic fluid visible?
- Check base frame for dimensions and structural integrity.
- Inspect for any bent or damaged metal parts.

B. REMOVING FROM PALLET:

Remove all packaging materials prior to removing the lift from the pallet. Visually inspect the lift as closely as possible.

Carefully pick up the lift taking into consideration the center of gravity of the lift with an overhead hoist or forklift. Use a hoist and nylon sling with a minimum of 2,000-lb capacity if you choose to pick the lift up with an overhead hoist.

Pick the lift up by the top cross member of the lift. Have all personnel completely cleared from the area because the lift will begin to swing when it is clear of the pallet.

Pick the lift up approximately six inches above the pallet. Once raised and secure remove the pallet from below the lift then lower the lift.

SECTION 4 **OPERATION**

A. OPERATING INSTRUCTIONS:

1. To raise the lift, push the control handle or activate the UP BUTTON on a remote control.
2. To lower the lift, pull the control handle or activate the DOWN BUTTON on a remote control.
3. Whenever the controls are released, the lift stops.

AUTHORIZED OPERATORS SHOULD READ AND UNDERSTAND ALL INSTRUCTIONS, PRECAUTIONS AND WARNINGS. IMPROPER USE OF THIS LIFT COULD RESULT IN INJURY AND/OR DAMAGE TO THE LOAD AND/OR EQUIPMENT.

- Inspect the lift for damaged or worn parts. Do not use if not in safe operating condition.
- Use lift only on hard level surfaces.
- Make sure load is evenly distributed, not loose or unstable and is as far back as possible on the platform or forks. Do not pick up loads on the tips of the forks or edge of platform.
- Adjust forks to the maximum practical width on a fork model lift if they are adjustable. Pick loads up on both forks, not one.
- Do not overload. Check load center and lift weight capacities that are located on the data plate.
- Make sure work area is clear of all obstructions.
- Check overhead clearance before lifting loads or transporting.

- Make sure floor lock pad is in firm contact with floor before lifting load, lowering load or using as a workstation.
- Brace or block lift when sliding loads on or off platform or forks.

B. DAILY OPERATIONS MAINTENANCE CHECKS:

1. Battery

- Check for corroded and loose terminals. A white powder substance will be present if there is any existing corrosion.
- Check for loose battery tie-downs.
- Visually inspect for any cracks or damage to the casing.

2. Charger

- Inspect wire connections.
- Check power cord for nicks/damage.
- Check charger for proper mounting.

3. Hydraulic System

- Inspect pump and cylinder for oil leaks.
- Check hydraulic oil level. Unscrew breather plug on power unit with forks platform fluid will be $\frac{1}{2}$ - $\frac{3}{4}$ of an inch from opening all the way down.
- Check hydraulic fittings and hoses

4. Frame Assembly

- Check floor lock.
- Check placement of safety screen.
- Check chain roller assembly.
- Check for any worn or damaged parts.

SECTION 5 **MAINTENANCE**

A. INSTRUCTIONS:

- Grease wheels and casters at least once a month to maintain easy roll of lift.
- Use only Hydraulic Oil (Conoco Super Hydraulic 32 or equivalent) in the hydraulic system. NEVER USE HYDRAULIC BRAKE FLUID.
- *Do not* overload your lift.

B. MONTHLY MAINTENANCE CHECKS:

reference.

1. Battery

- Clean terminals.
- Clean battery compartment area.
- Check specific gravity -- fully charged battery should read 1265.
- Check fluid level in all cells. Fill with distilled water as necessary to bring fluid to within $\frac{3}{4}$ " of the top.

2. Hydraulic System

- Clean and inspect hydraulic cylinder.
- Lubricate chains with a rust inhibitive chain lubricant.
- Check chain tension. The chains should be tight enough so that they do not come off the chain roller assembly. The tension should be adjusted so that the chains bear equal amounts of load weight.

3. Frame Assembly

- Clean and lubricate all roller bearings and cam followers.
- Clean and inspect all welds.
- Check wheels for wear and damage.
- Inspect nameplate for legibility. Place the serial and model number shown on the nameplate on the cover of the manual for future

SECTION 6

SERVICE

IF LIFT DOES NOT RISE TO FULL HEIGHT -- check for leaks or shortage of oil. Maintain the proper oil level.

IF THE LIFT TENDS TO CREEP DOWNWARD UNDER A LOAD -- a speck of dirt may be obstructing the seating of the valve and allowing leakage. To correct, follow these instructions:

- Raise lift to full lifting height and then lower it to lowest point of lift. It may be necessary to do this five or six times. In lowering the lift, lower it in stages, that is, lower the lift six inches to a foot at a time. This will dislodge the dirt and lift will operate properly.

Figure 1: Model WP

WP Component Identification	
Item	Description
1	Cylinder
2	Flow Control Valve
3	Chain Roller Assembly
4	Load Wheel
5	Floor lock Assembly
6	Lead Wheel

Figure 2: Model WPS

WPS Component Identification	
Item	Description
1	Cylinder
2	Flow Control Valve
3	Chain Roller Assembly
4	Load Wheel
5	Floor lock Assembly
6	Lead Wheel

Component Identification of Rear View of WP and WPS	
Item	Description
4	Load Wheel
5	Floor lock Assembly
6	Lead Wheel
7	Slave Wheel
8	Battery
9	DC Motor
10	Battery Charger
11	Steering Handle
12	Operating Lever

Figure 3: WP & WPS Rear View

Table 1: Steering Components

Steering Assembly Item and Part Numbers	
Item Number	Description and Part Number
1	N0338 - Washer
2	N0817 - Bolt
3	N0250 - Washer, Lock
4	1004-026 - Bearing
5	72045-6 - Shaft, Collar
6	1004-006 - Bearing Holder
7	1004-010 - Bar, Actuator
8	1004-043 - Pivot Assembly
9	1004-025 - Collar With Set Screw
10	1004-042-01 - Pivot Link (WP)
10	1004-042-02 - Pivot Link (WPS)
11	1004-030 - Assembly, Actuator
12	1004-024-01 - Spring
13	1004-028 - Assembly Handle
14	1004-022-02A - Caster Assembly with Actuator
15	N1255 - Pin (Expansion)
16	N1275 - Pin (Expansion)
17	N1280 - Pin Clevis
18	C101C8 - Wheel With Bearing 8x2, 1000# & 2000# Capacity
18	30001082 - Wheel With Bearing 8x2, 3000# & 4000# Capacity
19	1004-029 - Coupling
20	N1081 - Screw
20	N0280 - Washer
20	N0160 - Nut
20	1004-032-01 - Spacer

Figure 4: Steering Assembly

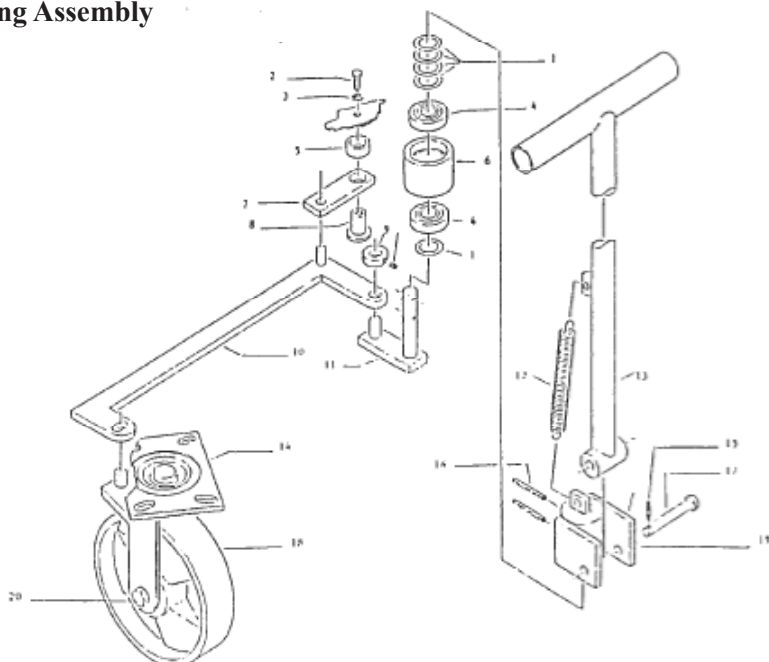

Figure 5: Floor Lock Assembly

Floor Lock Assembly Detail	
Item	Description
1	0574 – Handle, Lock
2	N0180 – Nut, Lock Handle
3	C108 – Spacer
4	N1110 – Bolt, Lock Handle
5	PSL28A – Rings, Retaining
6	PSL28 – Pin
7	PSL25 – Lever, Lock
8	N0180 – Nut, Locking
9	PSL22 – Stud, Adjusting
10	PSL24 – Mount, Rubber
11	PSL26 – Spring, Lock Return
12	PSL21D – Holder, Foot Pad
13	M437 – Pad, Foot

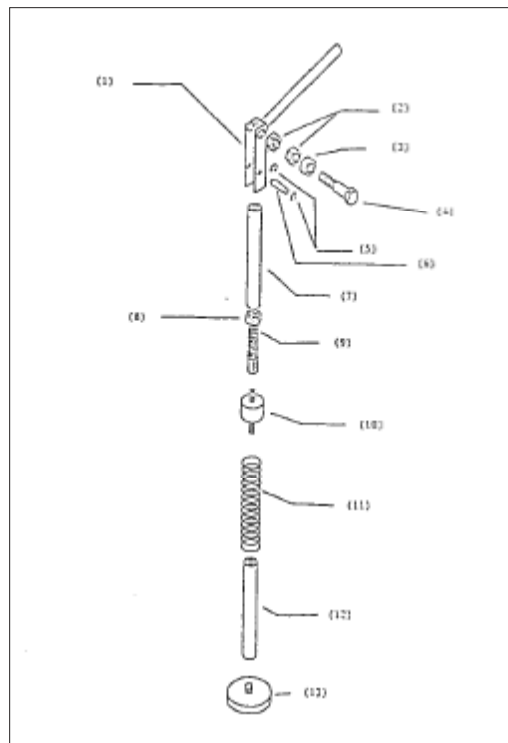

Figure 6: Chain Roller Assemblies; Assemblies Only, No Parts Available.

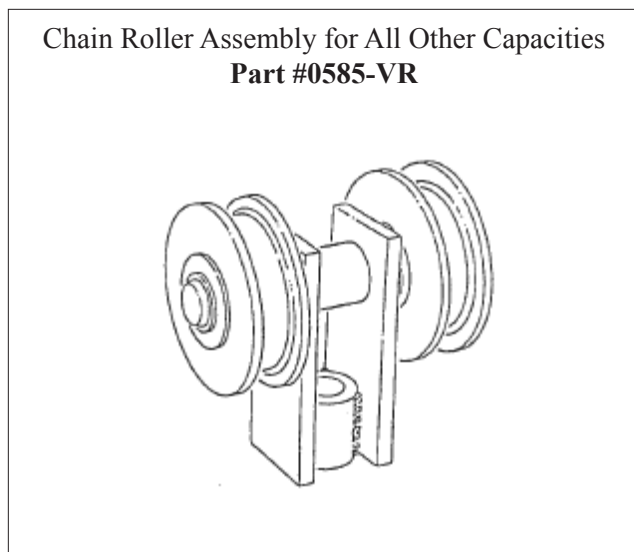
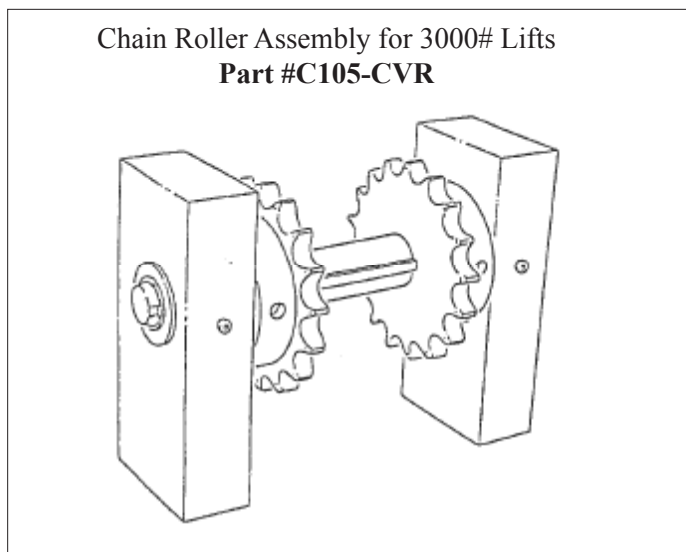

Figure 7: 1000, 1500 & 2700 lb. Cylinder

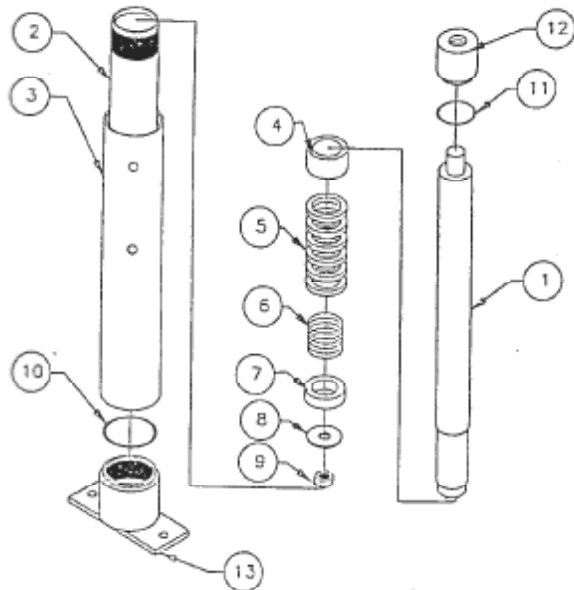

Figure 8: 2000 lb. Capacity Cylinder

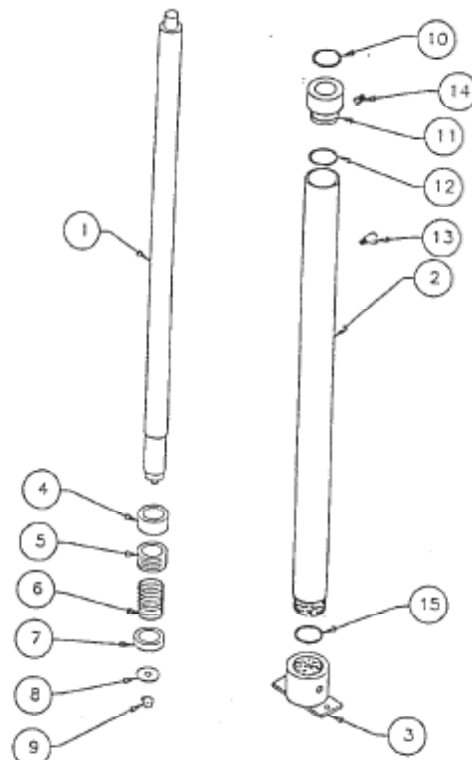
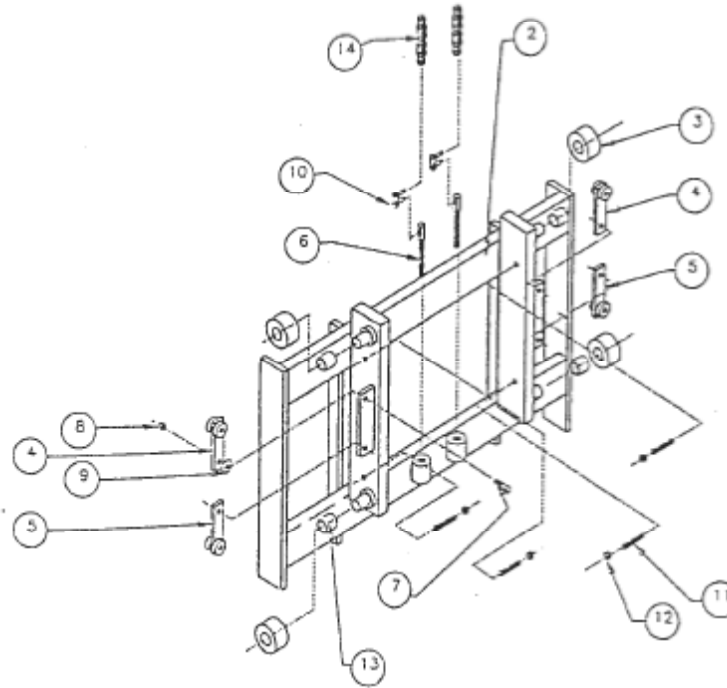

Table 2: Cylinder Components

Figure 3: Cylinder Parts for 1000 & 3000 Lifts		Figure 4: Cylinder Parts for 2,000 lb. Lifts	
Item	Description	Item	Description
1	Cylinder Ram - H108-XXX	1	Cylinder Ram - H108-2000-XXX
2	Inner Cylinder - H106-XXX	2	Inner Cylinder - H106-XXX
3	Outer Cylinder - H101-XXX	3	Base Cylinder - H107-2000
4	Bearing Chevron Support - H108A	4	Bearing Chevron Support - H108A-2000
5	Chevron Set - H109	5	Chevron Set - H109-2000
6	Chevron Spring - H111	6	Chevron Spring - H111-2000
7	Ram Guide - H112	7	Ram Guide - H112-2000
8	Washer Ram Guide - H113-2000	8	Washer Ram Guide - H113-2000
9	Nut Ram Guide - H114	9	Nut Ram Guide - N0130
10	“O” Ring Cyl. Base - H107A	10	“O” Ring Upper Cap - H104-2000
11	“O” Ring Ram Seal - H104-1000	11	Cylinder Cap - H105-2000
12	Cap Cylinder - H105-1000	12	“O” Ring Lower Cap - H105A-2000
13	Base Cylinder - H107-1000-1	13	Fitting - H102-2000
14	Seal Kit: Items 4-12 - H100K	14	Set Screw, Vent Plug - M411
		15	“O” Ring Ram Seal - H107-2000A
		16	Seal kit: Items 4-12 plus 15

Note: The “XXX” in a part number means that a raising height is required to substitute for the Xs. If the raising height is only two digits, a 0 is used to replace the first X to complete a part number.

Figure 9: Work Positioner Back Plate Assembly



Work Positioner Back plate Assembly

Note Item#1-A & -B include 2 thru 13

Item#	P/N#	Description	Qty.
1-A	1009-003-02A	Back plate and fork assembly 42" forks (forks not shown)	1
-B	1009-003-04A	Back plate and fork assembly 48" forks (forks not shown)	1
2-A	1009-003-02	Back plate and fork assembly 42" forks (forks not shown)	1
2-B	1009-003-04	Back plate and fork assembly 48" forks (forks not shown)	1
3	0462-02	Guide Roller Assembly	4
4	0564L	Guide Thrust Left	2
5	0564R	Guide Thrust Right	2
6	C106-27	Adjusting Stud	2
7	NO940	3/8-16x1 1/4 hex head bolt	4
8	NO100	3/8-16 hex nut	4
9	NO324	3/8 ID X 1" CD flat washer	4
10	L434	Link, connector	2
11	NO550	3/8-16 x 2" socket set screw	4
12	NO120	Nut, jam 3/8-16	4
13	C184	Race, bearing (loctite to stud)	4
14	C104-XX	Lift Chain	2

XX = Lift Chain

Figure 10:DC Power Wiring Schematic

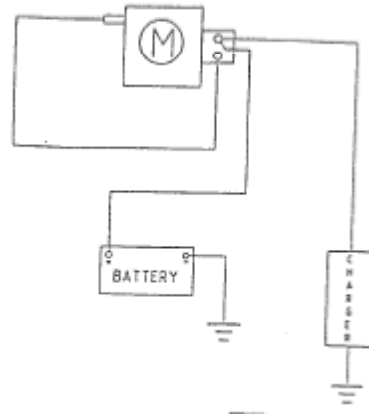

Figure 11: Old DC Power Pack

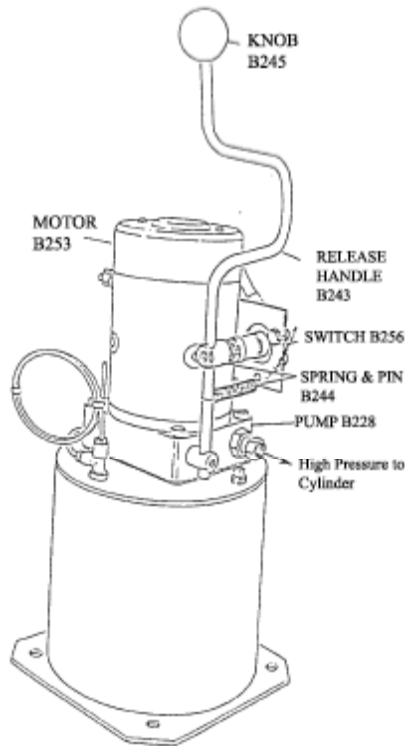

Figure 12: Old DC Power Pack w/ Remote Control

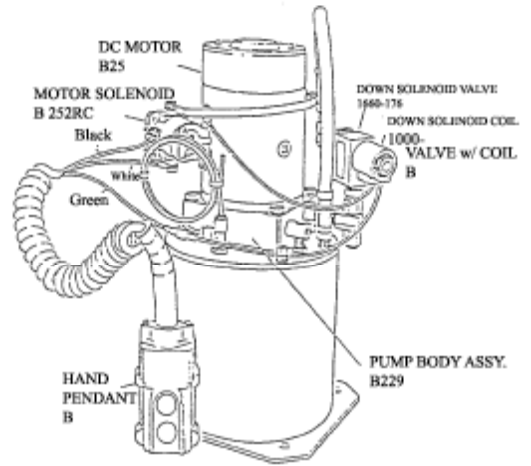

Figure 13: AC Power Wiring Schematic

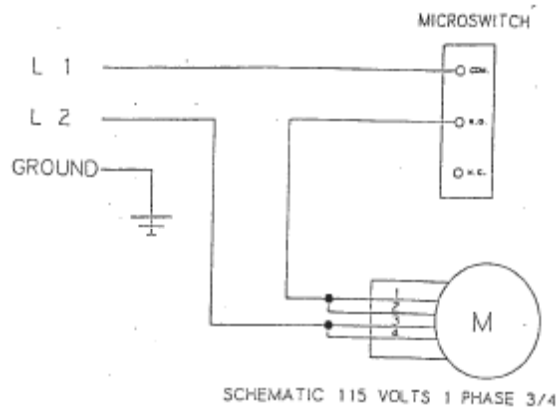

Figure 14: Standard AC Power Pack

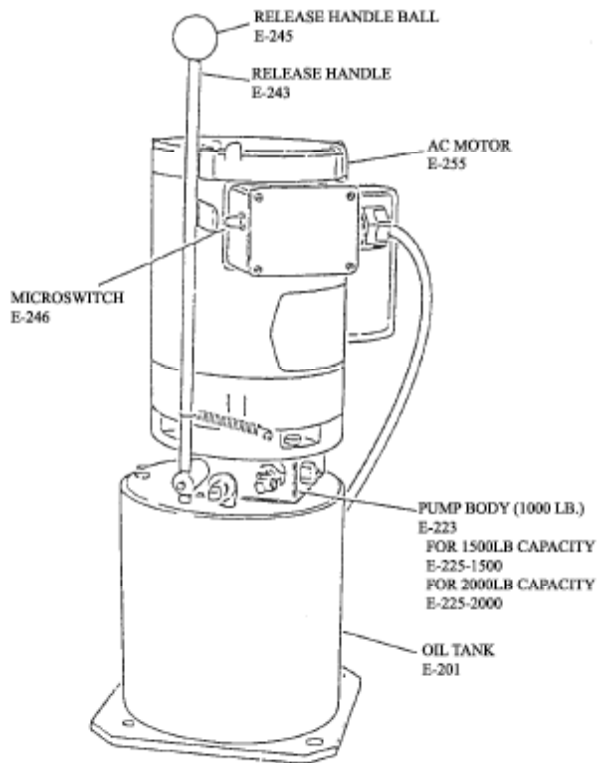

Figure 15: AC Power w/ Remote Control

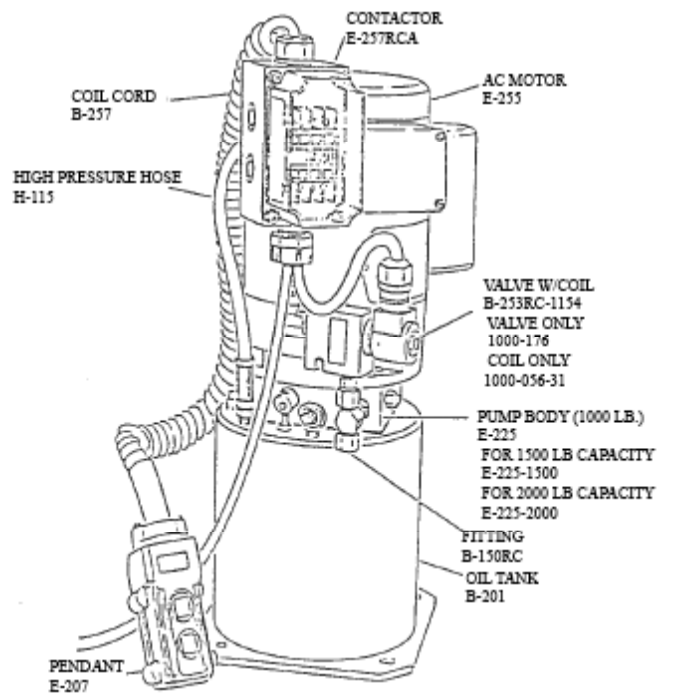

Table 3: Old Style Replacement Parts*

Description	Part Number	Used On
Power Pack: A completely assembled DC motor, pump and reservoir with manual control. Call Presto Lifts for part numbers if a remote control power pack is needed.	B200-1000 B200-2000 B200-3000 B200-4000	All 1000 lb. capacity models All 2000 lb. capacity models All 3000 lb. capacity models All 4000 lb. capacity models
Power Pack: A completely assembled AC motor, pump and reservoir with Pendant/s. Please specify the voltage and control/s.	E200-1000 E200-2000 E200-3000 E200-4000	All 1000 lb. capacity models All 2000 lb. capacity models All 3000 lb. capacity models All 4000 lb. capacity models
Pump Body For AC or DC Motor without Remote Control: Includes a B208 Pump Body Gasket.	B228-1000 B228-2000 B228-3000 B228-4000	All 1000 lb. capacity models All 2000 lb. capacity models All 3000 lb. capacity models All 4000 lb. capacity models
Pump Body For AC or DC Motor with Remote Control: Includes a B208 Pump Body Gasket.	E228RC-1000 E228RC-2000 E228RC-3000 E228RC-4000	All 1000 lb. capacity models All 2000 lb. capacity models All 3000 lb. capacity models All 4000 lb. capacity models
Oil Tank	B201	All lifts
Dipstick Gasket, Oil Level	B203	All lifts
Dipstick, Oil Level	B204	All lifts
Oil Tank Pipe Plug	B205	All lifts
Cap Screw Lock Washer, Oil Tank	B206	All lifts
Oil Tank Cap Screw	B207	All lifts
Pump Body Gasket	B208	All lifts
Oil Strainer	B209	All lifts
Pump Intake Nipple	B210	All lifts
Flow Control Valve	B211RC-A	All lifts
Pump Body Cap Screw	B221	All lifts
Pressure Release "O" Ring	B222	All lifts
Pressure Release Cam	B223	All lifts
Operating Lever, Manual for AC or DC Motor	B243	All lifts
Operating Lever, Spring/Connecting Pins	B244	All lifts
Operating Lever Knob	B245	All lifts
Battery Cable, Negative	B246	All lifts
Battery Cable, Positive	B247	All lifts
Battery Hold Down Kit	C140WPJK	All 1000# Lifts
Battery Hold Down Kit	C142aJK	All Remaining Lifts
Battery Charger, 10 AMP	B249A	All 1000# Lifts
Battery Charger, 15 AMP	B249B	All Remaining Lifts
Battery Charger Cord	B242	Both Chargers

*Not all parts are available for old style power units, call 800-343-9322 w/ serial number.

Description	Part Number	Used On
Switch, Manual for DC Motor	B256	All lifts
Switch Manual, Mounting bracket for DC motor	B252	All lifts
Switch, Connector to Motor for DC Motor	B257	All lifts
Motor, DC 12 volt	B258	All lifts
Oldham Coupling, DC Motor	B255	All lifts
Brushes, Set for Western DC Motor	B250W	All lifts
Brushes, Set for PrestoLite DC Motor	B250P	All lifts
Solenoid for DC Motor	B262RC	All lifts w/ Remote Controls
Solenoid Coil, for DC Down Flow	1000-056-03	All lifts w/ Remote Controls
Solenoid Valve, for DC Down Flow	B263RC-01	All lifts w/ Remote Controls
Solenoid Valve with Coil for DC Down Flow	B263RC	All lifts w/ Remote Controls
Hand Pendant for DC Power Packs	B268RC-B	All lifts w/ Remote Controls
Hand Pendant Coil Cord for DC Motor	B267RC	All lifts w/ Remote Controls
Operating Lever, Manual for AC Motor	E243	All lifts
Oldham Coupling, AC Motor	E254	All lifts
Motor, AC 3/4 HP 115 Volt	E255N	All lifts
Motor AC, Power Cord	E314	All lifts
Micro Switch for AC Motor	E246	All lifts
Hand Pendant for AC Power Packs	E307	All lifts w/ Remote Controls
Hand Pendant, Coil Cord for AC Motor	1001-172	All lifts w/ Remote Controls
Wheel w/Bearing, 8"x2", Available only in Nylon	C101C8	All 1000# & 2000# Capacity
Wheel w/Bearing, 8"x2", Available only in Nylon	1003-001-01	All 3000# & 4000# Capacity
Wheel w/Bearing, 3"x3", Available only in Nylon	1004-021	All non Straddle Lifts
Wheel w/Bearing, 5" Phenolic	C102PH	All Straddle Lifts
Wheel Shaft with Washer	C102	For C102PH Wheel
Safety Screen, 12"	C116-13	All 36" Travel Lifts
Safety Screen, 24"	C116-24	All 48" Travel Lifts
Safety Screen, 33"	C116-33	All 60" Travel Lifts
Chain	C104-36	All 36" Travel Lifts
Chain	C104-48	All 48" Travel Lifts
Chain	C104-60	All 60" Travel Lifts
Hydraulic Hose, 18" High Pressure	H116-18	All 3000# & 4000# Lifts
Hydraulic Hose, 29" High Pressure	H116-29	All Remaining Lifts
Hydraulic Hose, 6" Low Pressure	H115-2000P	All Lifts
Hydraulic Cylinder	H100-040	All 36" travel, 1000# or 3000# Lifts
Hydraulic Cylinder	H100-2000-040	All 36" travel, 2000# Lifts
Hydraulic Cylinder	H100-052	All 48" travel, 1000# or 3000# Lifts
Hydraulic Cylinder	H100-2000-052	All 48" travel, 2000# Lifts
Hydraulic Cylinder	H100-066	All 60" travel, 1000# or 3000# Lifts
Hydraulic Cylinder	H100-2000-066	All 60" travel, 2000# Lifts

*Not all parts are available for old style power units, call 800-343-9322 w/ serial number.

Ordering Replacement Parts

Presto Lifts has carefully chosen the components in your unit to be the best available for the purpose. Replacement parts should be identical to the original equipment. Presto Lifts will not be responsible for equipment failures resulting from the use of incorrect replacement parts or from unauthorized modifications to the unit.

Presto Lifts can supply all replacement parts for your lift. With your order, please include the model number and the serial number of the unit. You can find these numbers on the name plate. This plate is located within the cabinet, or the angle iron cylinder cross support.

To order replacement parts, please call the Presto Parts Department. Parts are shipped subject to the following terms:

- FOB factory
- Returns only with the approval of our Parts Department.
- Credit cards preferred (except parts covered by warranty).
- Freight collect for truck (except parts covered by warranty).
- Freight - prepaid and invoice for small parcel shipments (except parts covered by warranty).

Parts replaced under warranty are on a “charge-credit” basis. We will invoice you when we ship the replacement part, then credit you when you return the worn or damaged part.

Presto Lifts Parts Department

P.O. Box 1380, Portland, ME 04104-1380

Telephone: 800-343-9322

FAX: 888-788-6496

Email: Service@PrestoLifts.com

www.PrestoLifts.com

RESTOCKING POLICY

Presto Lift, Inc.'s goal is for you to be satisfied with your order. Merchandise may be returned, but returns will be subject to a restocking fee to cover the costs Presto Lift, Inc. incurs which include but are not limited to handling, storage of the units, etc. Presto Lift, Inc. will issue refurbishing costs where end-user wear is apparent. We would prefer to not charge for these costs but find it necessary any apologize for any inconvenience. Please review the RETURN MATERIALS AUTHORIZATION (RMA) PROCEDURES.

PARTS

Standard parts may be returned with a 20% restocking fee. Modified or custom-engineered parts are not returnable. Unfortunately, due to potentially concealed damage, all sales of electrical assemblies are final.

QUALITY ISSUES

Should you feel there is a quality problem, please contact the seller to ask questions and gather information on how to rectify the issue. Presto Lift Inc. reserves the right to determine potential credits, as a result of factory defects, based on its inspection of the merchandise.

GENERAL

All products shipped from our factory have passed Quality Assurance inspection and testing. The carrier of choice has signed for, and accepted the product in new working condition. The customer should inspect to ensure it is not received damaged, has no concealed damage or is not incomplete. Parts orders are determined to be complete based upon Presto Lift, Inc. inspection sheets and carrier shipping weights.

RETURN MATERIALS AUTHORIZATION (RMA) PROCEDURES

Although Presto Lift, Inc. is not legally obligated to issue a credit for any merchandise, the RETURN MATERIALS AUTHORIZATION (RMA) PROCEDURE is provided as a courtesy to our customers in the event they do not receive what they wanted.

If a customer wishes to return a Presto Lift, Inc. product, the first step in the process is to request an RMA number from Presto Lift, Inc.'s Customer Service Department. This request must be made on or before the thirtieth (30th) calendar day following the date of Presto Lift, Inc.'s invoice for the merchandise being returned.

The RMA number must appear on the outside of any packaging material for a return to be accepted and processed by Presto Lift, Inc. Customers shipping returns back to Presto Lift, Inc. from the Continental US, Canada and Mexico have fourteen (14) days from the effective date of the RMA to have the merchandise arrive freight prepaid at Presto Lift, Inc. Returns from locations other than the Continental US, Canada and Mexico must be shipped within the thirty (30) day period to arrive Free On Board (FOB) at Presto Lift Inc as soon as practical. If a customer believes Presto Lift, Inc.'s merchandise is defective, freight will be reimbursed to the original "Bill To" on the invoice if Presto Lift Inc. finds that the merchandise is defective.

Please remember that merchandise with RMA's coming back to Presto Lift Inc. from the Continental US, Canada and Mexico will not be accepted by Presto Lift Inc. if the returned goods do not arrive freight prepaid at Presto Lift Inc. within the thirty (30) day effective period.

All credits issued are less restocking fees as applicable, plus any assessed outbound/inbound in-transit damages.

Return addresses: please refer to your RMA for the address to which your product should be returned.

Presto Lifts Limited Warranty Policy

Presto Lifts warrants all of its products against defects in the welded structural frame and, if applicable, scissor legs from faulty material and workmanship for a period of five (5) years from the date of invoice.

A lifetime limited warranty is provided for the Airstroke Actuator™ in all pneumatic lifts against any defect due to faulty material or workmanship.

All batteries are covered under a separate limited warranty from the battery manufacturer for a period of one year from the date of invoice.

All other components have a limited warranty against defects in faulty material and workmanship for a two (2) year period from the date of invoice, batteries have a limited warranty against defects in faulty material and workmanship for ninety (90) day period from the date of invoice and 30 day limited warranty on labor. Please note that prior authorization from Presto Lifts is required on all warranty work.

There are no implied warranties of any kind, more specifically, there are no warranties of merchantability or fitness for any particular purpose. Presto Lifts' sole warranty shall be as set forth in this limited warranty.

Presto Lifts will elect to repair or replace a defective component without charge, if any components should become defective within the limited warranty period. Proof of purchase is required for warranty. The charge for shipping the defective component is the responsibility of the buyer and must be accompanied with an RMA number. The shipping charge to return the component to the buyer is the responsibility of Presto Lifts, Inc.

This limited warranty does not cover labor expense for removal or reinstallation of components after thirty days. This limited warranty shall not cover, among other things: damages resulting from foreign matter or water, failure to provide reasonable and necessary maintenance, and if applicable, use of product while charger is plugged into an AC outlet, or failure to follow operating instructions. The limited warranty is not valid for damage resulting from negligence, accident, unreasonable use, abuse or misuse, exceeding data plate capacities or altering the product without Presto Lifts authorization.

Presto Lifts expressly disclaims and excludes any liability for consequential, incidental, indirect or punitive damages or financial loss to people or property resulting from any breach of warranty or the operation or failure of this product.

Presto Lifts makes no representation that this product complies with local, state, or federal safety/product standards codes. Should this product fail to comply in any way with those codes, it shall not be considered a defect of materials or workmanship. Presto Lifts shall not be held liable for any damages resulting from noncompliance. It is the dealer's responsibility to exercise this limited warranty. This limited warranty is provided to the original purchaser (defined as the original end user) and is nontransferable. This constitutes the complete and final agreement involving Presto Lifts and limited warranty obligations for products.

Go Presto LIFTS™

MANY NEEDS REQUIRE
MANY OPTIONS...



Lift
Stik



Post
Tables



Double Lift
Table



Lift
Table



Portable
Lift



P3



Counterweight
Stacker



Pallet
Jack



Pneumatic
Lift/Tilt

Call Presto Sales
for stock or customized lift inquiries at

800-343-9322

Email: sales@prestolifts.com



Portable
Tilter



Floor
Level
Lift



Stacker