

Presto LIFTS
worldwide material handling
and ergonomic solutions

Power Stak

PPS2200-150AS



Installation, Operation and Service Manual

Model Number _____

Serial # _____

Date Placed in Service _____

**IMPORTANT: READ CAREFULLY
BEFORE INSTALLING OR OPERATING LIFT**

Part orders are subject to a \$50 minimum charge.

MAY 2012



Presto Lifts Limited Power Stacker Warranty Policy

Presto Lifts warrants the Power Stacker against defects on the mast, fork carriage, chains, pumps, DC motors, controllers, cylinders and wiring harnesses from faulty material and workmanship for a period of one (1) year from the date of invoice.

All wear items such as batteries, wheels, motor brushes, seals, bearings, hydraulic hoses, all switches, battery chargers and forks have a limited warranty against defects in faulty material and workmanship for a ninety (90) day period from the date of invoice and 30 day limited warranty on labor. Please note that prior authorization from Presto Lifts is required on all warranty work.

There are no implied warranties of any kind, more specifically; there are no warranties of merchantability or fitness for any particular purpose. Presto Lifts' sole warranty shall be as set forth in this limited warranty. Presto Lifts will elect to repair or replace a defective component without charge, if any components should become defective within the limited warranty period. Proof of purchase is required for warranty. The charge for shipping the defective component is the responsibility of the buyer and must be accompanied with an RGA number. The shipping charge to return the component to the buyer is the responsibility of Presto Lifts, Inc.

This limited warranty does not cover labor expense for removal or reinstallation of components after thirty days. This limited warranty shall not cover, among other things: damages resulting from foreign matter or water, failure to provide reasonable and necessary maintenance, and if applicable, use of product while charger is plugged into an AC outlet, or failure to follow operating instructions. The limited warranty is not valid for damage resulting from negligence, accident, unreasonable use, abuse or misuse, exceeding data plate capacities or altering the product without Presto Lifts authorization.

Presto Lifts expressly disclaims and excludes any liability for consequential, incidental, indirect or punitive damages or financial loss to people or property resulting from any breach of warranty or the operation or failure of this product.

Presto Lifts makes no representation that this product complies with local, state, or federal safety/product standards codes. Should this product fail to comply in any way with those codes, it shall not be considered a defect of materials or workmanship. Presto Lifts shall not be held liable for any damages resulting from noncompliance. It is the dealer's responsibility to exercise this limited warranty. This limited warranty is provided to the original purchaser (defined as the original end user) and is nontransferable. This constitutes the complete and final agreement involving Presto Lifts and limited warranty obligations for products.

This manual was current at the time of printing. To obtain the latest, most updated version, please contact the Customer Service Department or go to our website: www.PrestoLifts.com -- you will find a complete list of current Owner's Manuals to print.

TABLE OF CONTENTS

SECTION 1:	
Limited Warranty	2
Introduction.....	4
SECTION 2:	
Safety	4-5
SECTION 3:	
Installation.....	6
A. Inspection	6
B. Removing from Pallet	6
C. Preparation for Use.....	6
Wheel Traction & Straddle Leg Set-Up.....	7
SECTION 4:	
Operation.....	8-10
A. Operating Instructions.....	8
Suggested Daily Operator Checklist.....	9
B. Daily Operations Maintenance Checks	10
SECTION 5:	
Battery Maintenance	10
A. Preparing to Charge a Battery	10
B. Charging the battery	10
C. Warnings and Battery Info.....	10
D. Battery maintenance.....	10
E. Charger Operation	11
SECTION 6:	
Maintenance	11
A. Weekly Operations Maintenance Checks.....	11
B. Monthly Operations Maintenance Checks	11
SECTION 7:	
Troubleshooting	12
ORDERING REPLACEMENT PARTS.....	37
RESTOCKING POLICY.....	37
RETURN GOODS AUTHORIZATION.....	38

LIST OF FIGURES:

Fig. 1: Operational Buttons.....	6
Fig. 2: PPS2200-150AS Exploded View.....	13
Fig. 3: PPS2200-150AS Inner Mast	14
Fig. 4: Cylinder View	15
Fig. 5: Caster Wheel Assembly	16
Fig. 6: Drive Wheel Assembly	17
Fig. 7: Control Pod.....	18
Fig. 8: Steering Assembly	19
Fig. 9: Power Unit Assembly.....	20
Fig. 10: PPS2200-150AS Carriage Assembly	21
Fig. 11: Labels & Precautionary Warnings.....	22
Fig. 12: Electric Control Panel (<i>Prior to Nov. 2008</i>).....	23
Fig. 13: Electric Control Circuit (<i>Prior to Nov. 2008</i>)	24
Fig. 14: Wiring (<i>Prior to Nov. 2008</i>)	25
Fig. 15: Wiring Diagram (<i>Prior to Nov. 2008</i>)	26
Fig. 16: Wiring Diagrams (<i>Nov. 2008 to Present</i>).....	27
Fig. 17: Wiring Diagrams (<i>Nov. 2008 to July 2011</i>)	28
Fig. 18: Wiring Diagrams (<i>Aug. 2011 to Present</i>).....	29
Fig. 19-24: Wiring Diagrams (<i>Nov. 2008 to Present</i>) ...	30-35

LIST OF TABLES:

Table 1: Recommended Spare Parts List.....	36
--	----

SECTION 1

INTRODUCTION

This manual attempts to provide all of the information necessary for the safe and proper installation, operation and maintenance of Presto Lifts Inc. battery operated, Power Stak. It is important that all personnel involved with the installation, maintenance or operator of the stacker read this manual. Additional manuals are available upon request or at www.PrestoLifts.com.

Each Presto stacker is equipped with nameplate, serial number and model identifications. Please refer to these numbers when ordering parts or requesting further information.

The Presto stackers are designed for lifting, lowering and positioning a wide variety of loads. WHERE UNIQUE SITUATIONS ARISE, WHICH ARE NOT COVERED IN THIS MANUAL, CALL PRESTO LIFTS FOR FURTHER INSTRUCTIONS.

The battery operated stackers are designed for in-plant/non-hazardous locations only. They can be used in a 8' or larger aisle. These units are not for personnel lifting.

SECTION 2

SAFETY

You must be trained and certified to operate this powered stacker. Federal law states that only properly trained operators are permitted to operate a powered industrial stacker and that your employer must train you and certify that you are qualified. (OSHA 1910.178 29QFR-7-1-06 Edition)

Presto lifts does not offer operator training. Operator training programs may be offered by your local Presto Lifts dealer or obtained online. Enter, "powered industrial truck operator training" into a search engine.

The battery operated stackers are very powerful lifts capable of doing large amounts of work.

DO NOT OPERATE THESE LIFTS WITHOUT CAREFULLY READING THIS MANUAL. In order to provide for the safe operation of these stackers, Presto Lifts Inc. has identified certain hazards that may occur during the maintenance and use of these lifts. For safety reasons these units are designed to be serviced or repaired in the fully lowered position. If performed properly, this will greatly reduce the possibility of injury.

!WARNING To avoid bodily injury read, understand and follow all instructions before operating this machine.	LIFTING CAPACITY ABOVE 7' IS LIMITED	
	Maximum Lifting Capacity	
	UP TO 7' 2,200 LBS.	UP TO 8' 1,800 LBS.
	Ratings based on 24" Load Center See Owner's Manual for details 10055255	

!WARNING To avoid bodily injury read, understand and follow all instructions before operating this machine.	LIFTING CAPACITY ABOVE 7' IS LIMITED			
	Maximum Lifting Capacity			
	UP TO 7' 2,200 LBS.	UP TO 8' 1,800 LBS.	UP TO 10' 1,500 LBS.	UP TO 12' 1,200 LBS.
	Ratings based on 24" Load Center See Owner's Manual for details 10055253			

!WARNING To avoid bodily injury read, understand and follow all instructions before operating this machine.	LIFTING CAPACITY ABOVE 7' IS LIMITED		
	Maximum Lifting Capacity		
	UP TO 7' 2,200 LBS.	UP TO 8' 1,800 LBS.	UP TO 10' 1,500 LBS.
	Ratings based on 24" Load Center See Owner's Manual for details 10055256		

WARNING!

When servicing the unit:

1. Key should be in "OFF" position.
2. E-stop should be depressed.
3. Disconnect the batteries at the terminals.
 - Do not perform any repair work on lifts if there is a load on the forks or platform.
 - Do not perform any repair work if the forks or platform is in the raised position.
 - All personnel must stand clear of the lift while in motion.
 - Do not put hands or feet under the forks or platform.
 - Do not stand underneath the forks or platform.
 - Do not stand in front of the stacker while in motion.
 - Do not stand, sit or climb on the lift.
 - Do not use the lift on soft, uneven or unstable surfaces.
 - Do not exceed the load center or capacity.

WARNING!

You or others around you can be seriously injured or even killed if you don't use this stacker correctly. Read and obey all warnings and instructions in this manual and on the stacker. It is your responsibility before starting work to make sure it is in good working order.

Always be alert to the area around you and watch where you are walking. Be careful that you don't get pinned or crushed between the stacker and a fixed object such as a wall or post.

- Watch your hands and feet. A foot or hand caught between the stacker and a fixed object will be crushed or even cut off.

- If traveling forks first, keep both hands on the control handle and be careful when changing direction of travel. Keep your feet clear of the stacker.
- Keep the stacker under control at all times. Operate at a speed that allows you to stop safely. Be even more careful on slippery or uneven surfaces. Do not run over objects on the floor.
- Perform all stacker movements smoothly and at a speed that will give you time to react if an emergency occurs.

Tipovers and falls are very serious accidents; you can be crushed or even killed. To prevent injury, know where you are at all times and follow the rules of safe stacker operation.

- Be careful when working around docks, dockboards and trailers. Stay away from the edge of docks and ramps. Check to make sure the wheels of truck or trailers are chocked.
- Travel with the load or forks close to the ground. Watch for overhead obstructions. Perform all stacker movements smoothly and at a speed that will give you time to react in an emergency.
- Keep your hands and feet away from all moving parts such as masts, chains, forks or wheels.
- Never stand on or under the forks, or allow anyone else to stand on or under them. Never ride on the stacker or allow anyone else to ride. There is no safe place to sit or stand.
- Before you leave your stacker, be sure to lower the forks to the floor. Shut the stacker off with the key.

WARNINGS

- DO NOT** use this stacker until you have been trained and authorized to do so.
- DO NOT** operate until you have read all warnings and instructions.
- DO NOT** exceed load center or load weight capacities (check capacity plate).
- DO NOT** operate until you have checked the conditions of the stacker: lift systems, forks, chains, and cables.
- DO NOT** use if any part is damaged, worn or not working properly.
- DO NOT** use on ramps or inclines. Only smooth level surfaces.
- DO NOT** use for lifting or carrying people.
- DO NOT** handle unbalanced, unstable or loosely stacked loads.
- DO NOT** travel with forks or platform in an elevated position.
- DO NOT** handle tall, unsecured or unstable loads that could fall.
- DO NOT** allow people to stand or pass under forks or platform with or without load.
- DO NOT** operate when parts of anyone's body may be close to mast structure or any moving parts.
- DO NOT** drop loads on platform or forks.
- DO NOT** alter or modify this stacker in any way.

SECTION 3 INSTALLATION

A. INSPECTION:

Upon receipt of the stacker, inspect the equipment completely to determine if there is any shipping damage, and that the lift is complete. Presto tests and inspects every piece of equipment prior to shipment. If damage is apparent, a freight claim must be filed with the freight company. Do not use the stacker if there appears to be any damage. With the stacker in a lowered position, check the following:

- Check for signs of damage especially to the back cabinet that houses the battery, electrical/hydraulic power pack.
- Check all electrical and hydraulic connections for tightness.
- Remove back panel.
 1. Turn key switch to "OFF" position.
 2. Push in E-stop and unscrew the red knob,
 3. Lift off back panel. There is enough wire to the key switch to allow the panel to be set aside.
- Inspect for any bent or damaged parts.

B. REMOVING FROM PALLET

Each of the Presto stackers is shipped out on a pallet or skid. Prior to removing the unit from the pallet or skid, remove all tie down straps and packaging. Visually inspect the unit as closely as possible.

With an overhead hoist or forklift, carefully pick up the unit taking into consideration the center of gravity of the unit. If you choose to pick the unit with an overhead hoist, use a nylon sling and hoist with a minimum of 2,000-lb. capacity. The nylon sling will not do any damage to the steel construc-

tion of stacker. Pick the unit up. On conventional masts use the top cross member of the lift. On narrow masts the cover must be removed to access lifting equipment. Be careful of the stacker swinging once fully lifted off the pallet or skid. Have all personnel completely cleared from the area.

Pick the unit up approximately six inches above the pallet or skid. Once raised, remove the pallet or skid from below the lift. Do not move the lift around in the air. Lower the stacker on the ground.

C. PREPARATION FOR USE

This stacker left our factory in new condition. It has been inspected and weight tested to assure all performance standards have been met.

Visually inspect the stacker for damage. Check for attachments and accessories that may have been ordered. If there is any damage or missing parts, report it to your carrier and your Presto dealer immediately.

Remove all metal/plastic bands, cardboard and other material used for shipping purposes.

Check to see if chains are in place, and that the lift system is in working order. Inspect for oil leaks.

See instructions for removing back panel on pg. 5.

Connect battery cable. Check cables and wires on battery charger as well as battery.

Figure 1: Operational buttons

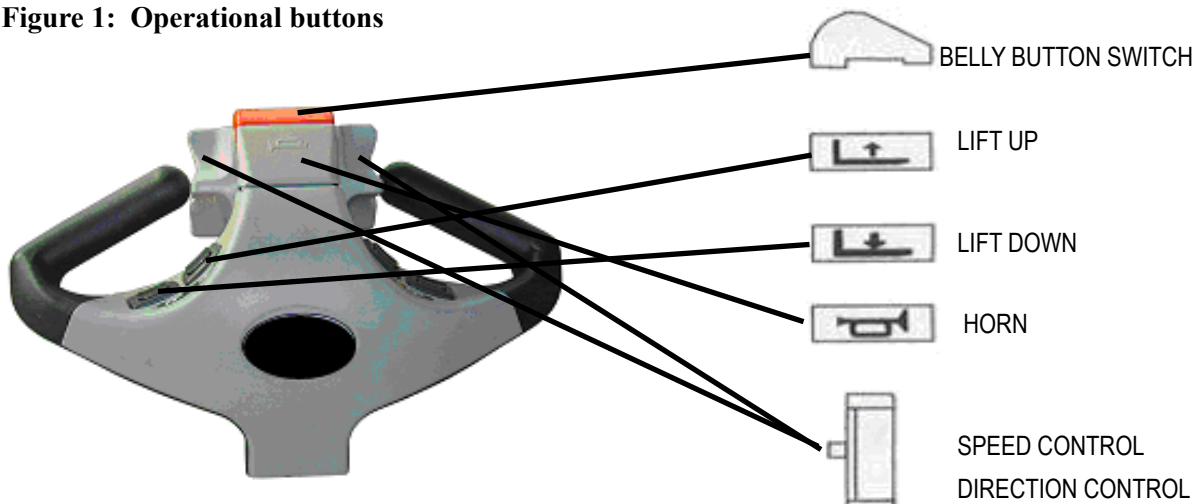

CRITICAL PROCEDURE FOR PROPER WHEEL TRACTION

Proper Drive Wheel traction is obtained for the PowerStak Straddle unit using this Procedure

All PowerStak Models are designed and intended to operate on an unfinished concrete floor surface. If any PowerStak is operated on smooth or polished concrete, sealed concrete, epoxy sealed floor, linoleum or other smooth surfaces Drive Wheel traction performance may be affected; If traction issues are encountered Rubber Drive Wheels are available through special order. **Please contact Customer Service at Presto Lifts 1-800-343-9322**

When any PowerStak is operated on a wet, oily, powdery, sandy or non-uniform liquid or granular surface Drive Wheel traction performance will be affected and loss of traction will occur.

SET-UP PROCEDURE FOR POWERSTAK STRADDLE LEGS

NOTE: STRADDLE LEGS MUST BE ADJUSTED IN ACCORDANCE WITH THIS PROCEDURE

1. PowerStak unit located on flat, clean uniform surface, unloaded, forks raised a minimum of 1" off the floor
2. Determine the desired/required straddle width dimension (2 inches greater than pallet width, 1" on each side of the pallet or load, up to a maximum of 50 inches inside width)
3. Be sure to fully loosen all bolts before moving stabilizing legs. Adjust one stabilizer leg at a time – using a pry bar, pinch bar, rubber mallet etc. move the straddle leg out from the base tube to the desired position. Do not move too far, see picture below, if the ¼" wide painted White Line is visible the leg is pulled out too far; Maximum movement 5 ½" for each leg for 2200 pound units, 4 ½" for each leg for 3000 pound units.
4. Adjust second Straddle Leg – using a pry bar, pinch bar, rubber mallet etc. move the straddle leg out from inside the base tube to the desired straddle width position.
5. **Straddle Legs must be symmetrically adjusted, both legs adjusted to the same extended dimension!**

CRITICAL – STRADDLE BOLT TIGHTENING SEQUENCE & PROCEDURE

Set up procedure for PowerStak Straddle legs with 3 or 4 Bolts:

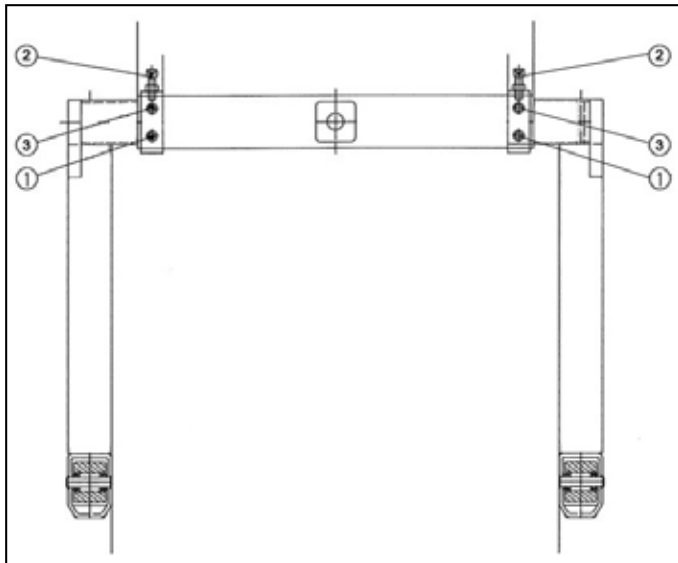

Back off all bolts and follow steps

- First - tighten Bolt 1 to **85 foot pounds**.
Second - tighten Bolt(s) 2 to **85 foot pounds**.
Third - tighten Bolt 3 to **25 foot pounds** - *NOT 85*.
Last - securely tighten all lock nuts.

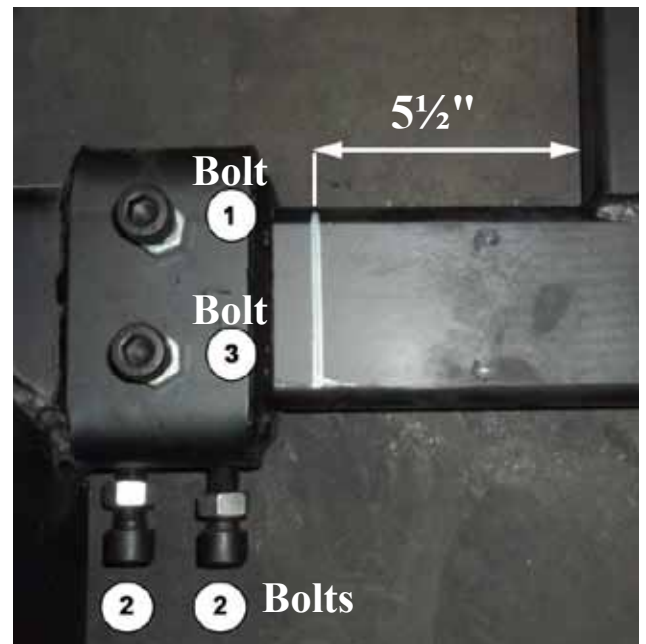

NOTE: _____
When adjusted correctly, white line cannot be seen.

SECTION 4

OPERATION

A. OPERATING INSTRUCTIONS:

To Raise and Lower:

There are two buttons located on both sides of the handle. The inside one is for raising the forks. The outside one is for lowering the forks. When operating, always make sure the load being lifted is within the loading capacity of your stacker and the load has been stacked safely on the pallet. Also, make sure that the length of the forks corresponds to the length of the pallet. In this way, the load rollers will place themselves in the opening at the end of the pallet, so that when you raise the forks, you will not break the bottom boards of the pallet. Always make sure that when entering the pallet that the forks are in the fully lowered position. Be careful when lifting pallets that are too short or too long for the stacker. It might destroy your pallet by breaking the bottom boards, and if the forks project through the end of the pallet, the tips of fork may go into the next pallet that is behind the pallet that you are lifting, which may bend the tips of forks and overload the capacity of the stacker.

To Travel:

To travel, rotate the butterfly controls throttle on the upper part of the handle. When rotating the butterfly control CW towards the forks, the stacker runs forwards in the forks first direction. When rotating the butterfly CCW towards you, the stacker runs backwards in the handle first direction. Always make sure the stacker clears any obstruction when traveling, and that your path of travel is clear of people. Never carry loads above the loading capacity of the stacker. It is suggested that when traveling without a load, the forks be in the lowered position. The speed of the stacker is increased by the degree of the rotation in either direction; it functions like a throttle. When you release your hand from the butterfly control, it automatically will resume to the neutral position and the speed of the stacker will slow down.

To Brake:

Your stacker is equipped with a magnetic brake. The brake is applied when the handle is in its vertical position between 10 – 15 degrees and lowered position between 80 – 90 degrees. The brake could be released when you pull down the handle at any point between 15 – 80 degrees. Always make sure the brake is released before operating the stacker. When the stacker is running, you could brake the stacker by raising the handle to its vertical position or lowering the handle to its lowest position. Or, to turn the butterfly controls in the opposite direction, the change in direction of the motor will slow down, stop, and reverse the direction of stacker. **When parked**, always put the handle in the full vertical position with the brake applied and the forks in lowered position.

Reversing Safety:

At the end of the handle there is a large, red reversing bar (belly button switch) that is designed to protect the operator from injury. When the operator runs the stacker backwards, and the end of the handle comes in contact with the operator's body, the stacker will automatically reverse direction and travel away from the operator. When the reversing safety bar comes in contact with your body during operation, immediately release your hands from the butterfly control and put the handle up to its vertical position or down to its lowest position and the brake is on. The reversing safety bar will automatically resume to its original position after being activated.

Horn:

As standard equipment, a horn that is located on the top of the handle.

**AUTHORIZED OPERATORS SHOULD READ
AND UNDERSTAND ALL INSTRUCTIONS,
PRECAUTIONS AND WARNINGS.
IMPROPER USE OF THIS LIFT TRUCK COULD
RESULT IN INJURY AND/OR DAMAGE
TO LOAD AND EQUIPMENT.**

DAILY OPERATOR CHECK LIST

CHARGE CONDITION/BATTERY CHECK LIST

1. Check Battery Discharge Indicator (Fuel Gage and Hour Meter) – Be sure unit is showing **proper Charge Level** before operating unit
2. Check to be sure **Charging Cord** is **Unplugged** and properly stowed before operating unit
3. Inspect Battery Wire Connections – All connections should be tight with **No Corrosion** (white powder) showing at the **Battery Terminals**
4. Inspect Battery Case – There should be **no cracks or visible damage** to the **Battery Case**

WALK AROUND INSPECTION

1. Check general condition of Stacker (loose or broken parts, oil, dangling wires, dents, cracked covers etc.)
2. Check metal frame, mast, carriage and front load supports for cracked welds, worn or flat rollers, loose or disconnected chains, loose pins, missing snap rings, and loose or missing hardware – bolts, nuts washers etc.
3. Check for evidence of hydraulic leaks
4. Make sure all precautionary labeling is in place and legible

FUNCTIONAL INSPECTION

1. Check Drive – Forward and Reverse Function
2. Check Lift – Up and Down Function
3. Check Function for Belly Button Reverse
4. Check Horn Function
5. Check Brake Function

OPERATOR ID _____ DATE _____

DO NOT USE OR OPERATE STACKER IF ANY FUNCTION IS NOT OPERATING PROPERLY OR IF STACKER APPEARS UNSAFE IN ANYWAY

REPORT CONCERNS TO SUPERVISOR IMMEDIATELY!

SECTION 5

BATTERY MAINTENANCE

A. PREPARING TO CHARGE A BATTERY

1. Always turn off E-stop and key switch before working with the batteries.
2. Be sure the area around the stacker and the battery is well ventilated while battery is being charged.
3. The battery terminals, connections and wiring connections should be clean and free of corrosion. When cleaning any of these components wear a face shield or other suitable protective eyewear.

B. BATTERY CHARGING

Charging must be performed with the charger that is provided with or prewired into the machine. During charging, the temperature in the battery must not exceed 120 F. Charging simultaneously with truck operation is not recommended. Plug the charger into a 115V outlet. Charge until the battery gauge indicator lights show fully charged (approximately 6-8 hours).

C. WARNINGS AND BATTERY INFORMATION

Avoid use of open flame near batteries. At temperatures around freezing point, battery capacity is reduced by 30%. The battery terminals, connections and wiring should be clean and free of corrosion. When cleaning any of these components, wear a face shield or other suitable protective eyewear. Read, understand, and follow all battery and battery manufacturer's specific precautions while working with and/or charging batteries.

D. BATTERY MAINTENANCE

To measure the voltage, use a digital voltmeter (DC) on the battery poles. The truck must not have been in use for the previous 30 minutes.

DANGER

Never alter the AC cord or plug provided. If it will not fit outlet, have proper outlet installed by a qualified electrician. Improper connection can result in a risk of an electric shock.

1. Disconnect the charger from the 110 volt wall outlet once the indicators read fully charged.

Note: The batteries are designed for intermittent use. Continual usage will wear the battery out and charging will be required.

- Inspect the lift for damaged or worn parts. *Do not* use if not in safe operating condition.
- Use lift on hard level surfaces only.
- Make sure load is evenly distributed, not loose or unstable, and is as far back on platform or forks as possible. *Do not* pick up loads on tips or forks or edge of platform.
- For fork models, adjust forks to the maximum practical width. Pick up loads on both forks.
- *Do not* overload. Check load center and load weight capacities on the nameplate.
- Make sure travel and work area is clear of obstructions.
- Check overhead clearance before lifting loads or transporting.

B. DAILY OPERATIONS MAINTENANCE CHECKS:

1. Battery

- A. Check for corroded and loose terminals. A white powder substance will be present if there is any existing corrosion.
- B. Visually inspect for any cracks or damage to the casing.
- C. Check for loose battery tie-downs.

2. Charger

- A. Inspect wire connections.
- B. Check power cord for nicks/damage.
- C. Check power charger for proper mounting.

3. Hydraulic System

- D. Inspect pump and cylinder for oil leaks.
- E. Check hydraulic oil level.
- F. Check hydraulic fittings and hoses.
- G. Check ram for nicks/damage.

4. Frame Assembly

- A. Check chain roller assembly connections.
- B. Check for any worn or damaged parts.

NOTICE

When to charge the battery?

Allow the machine to stand idle for at least one hour. Check the Battery Discharge Indicator. If 6 bars or less are lit, it is time to charge the battery.

See owner's manual for charging instructions.



VOLTAGE

- Approx. 12.7 V..... Fully charged
- Approx. 12.2 V..... 1/2 charged
- Approx. 12.0 V..... 1/4 charged
- Approx. 11.6 V..... Discharged

E. CHARGER OPERATION

Power Lamp

1. Green: Connection correct. Charger will operate normally.
2. Red: Bad connection or bad battery.

Fault

1. Red light blinks 3 times in 5 seconds: The output between charger is faulty, loose, or bad connection
2. Red light blinks 5 times in 5 seconds: The temperature is too hot for the charger to operate.
3. Building power is not compatible; too low or too high. +/- 10% is the general rule.

Charge Lamp

1. Red: Charger can charge normally. The battery is less than 70%
2. Orange: Battery is between 70% and 100% charged.
3. Green: Battery is at 100%. Fully charged.
4. No light: The charger can not charge the battery. Voltage of the battery may be too low to cause the charger to start. It must be at 9 volts to initiate charge.

SECTION 6 **MAINTENANCE**

Operation of Presto Power Stak is very simple — as is their construction. They require very little maintenance. Reasonable care will result in excellent trouble-free performance. The Power Stak is designed for one-man operation and ease of performance.

- Grease floor wheels and casters at least once a month.
- Use only Hydraulic Oil AW32 or Dextron III in the hydraulic system.
- *Do not* overload your lift.
- Check brakes, steering mechanisms and controls before each use.

A. WEEKLY OPERATIONS MAINTENANCE CHECKS:

1. **DAMAGE:** Check for bent, dented, worn or broken parts.
2. **LIFT SYSTEM:** Check to assure that there is no binding or excessive play in the forks. Check for quiet and smooth operation of the lift cylinder. Check all moving parts and linkage.
3. **LEAKS:** Check hydraulic system for leaks and hydraulic oil level.
4. **WHEELS AND CASTERS:** Check for wear and that

they are turning smoothly.

5. **LIFT CHAINS:** Check to see that they are in place and not loose.
6. **FORKS:** Check that they are not bent or cracked.
7. **BRAKES:** Ensure brakes work properly.
8. **CABLES; WIRES:** Check that there are no loose cables or wires.
9. **LABELS:** Ensure all precautionary labels and guards are in place.

B. MONTHLY OPERATIONS MAINTENANCE CHECKS:

1. **Battery (maintenance free)**
 - A. Clean terminals.
 - B. Clean battery compartment area if there are signs of corrosion.
2. **Hydraulic System**
 - A. Clean and inspect hydraulic cylinder.
 - B. Lubricate chain with a rust inhibitive lubricant (light machine oil).
 - C. Check chain tension. It should be even on both chains. The chain should be tight enough so that it does not come off of the roller assembly.
3. **Frame Assembly**
 - A. Clean and lubricate all roller bearings, cam followers and all moving parts.
 - B. Clean and inspect all welds.
 - C. Check wheels for wear and damage.
 - D. Inspect nameplate for legibility. Place the serial and model number shown on the nameplate on the cover of the manual for future reference.
4. **Electrical**
 - A. Check batteries, motors, controllers, limit switches, electrical conductors and connections.

CAUTION:

DO NOT USE LIFT IF IT IS NOT OPERATING PROPERLY, OR APPEARS UNSAFE IN ANY WAY!

SECTION 7

TROUBLESHOOTING

Before starting the troubleshooting, you have to:

- A. Put the truck on an even and solid surface.
- B. Turn off key switch or disconnect the battery terminals.

1. Unit will not lift (motor does not run)

- Faulty wiring from fuse to lift switch in handle
- Faulty lift switch
- Faulty wiring from battery positive terminal to pump contactor to pump motor
- Burned out brushes in pump motor
- Low hydraulic pressure caused by:
 - Pressure relief valve needs adjustment
 - Pump check valve stuck open
 - Faulty solenoid valve
- Faulty wiring from lift switch to solenoid
- Faulty lift contactor
- Defective control circuit fuse
- Chain or roller bound
- Check oil level

2. Forks will not lower

- Look for binding in chains or rollers

3. No electrical power

Dead Batteries:

- Key switch on "OFF" position
- E-stop button depressed
- Loose or dirty battery connections
- Blown fuse(s)
- Faulty wiring from fuse to travel control switch
- Faulty control switch
- Faulty wiring from travel control switch direction contactor
- Faulty contactor

4. No Traction

- Idler wheel needs adjustment

IDLER WHEEL ADJUSTMENT

The following is a procedure for adjusting the idler wheel on the Presto PowerStak. Under normal conditions this should not be necessary because the idler wheel has been adjusted at the factory.

Tools Needed:

Phillips head screw driver

Medium crescent wrench

1 block of wood (2 x 4)

1. Place unit on a flat surface.
2. Turn key to the OFF position and push emergency stop button down.
3. Remove the 2 screws from the main orange cover that covers the unit.
4. Remove the emergency stop button by unscrewing.
5. Slide the main cover up and place the block of wood under the right hand side to hold open exposing the idler wheel and adjusting the screw.
6. With the adjustable wrench loosen the jam nut on the idler wheel adjusting screw.
7. Loosen the adjusting screw until you have no tension between the adjusting screw and idler wheel. You will have some play between the idler wheel and the left front wheel.
8. Now tighten the screw until you just make contact with the idler wheel. Continue adjusting until the idler wheel just touches the floor.
9. Tighten jam nut. You may have a slight rocking back and forth, from the left front to right rear idler wheel, but this is not uncommon.
10. Now remove the wooden block and lower the cover back into place inserting the 2 screws and tighten. Screw the E-stop button back on.
11. Your adjustment is complete

If the wheel is worn, replace wheel

Figure 2:

PPS2200-150AS Exploded View

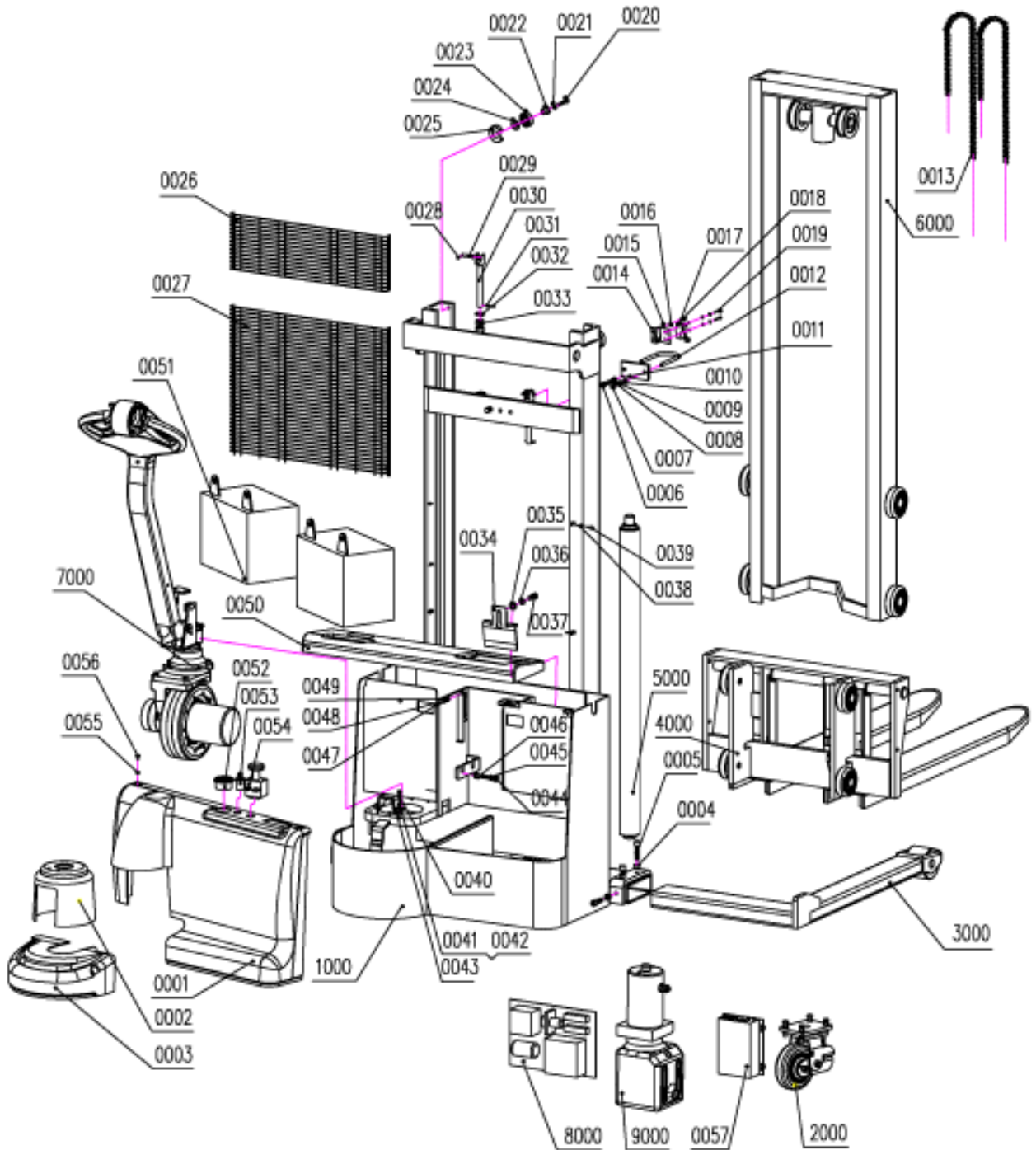
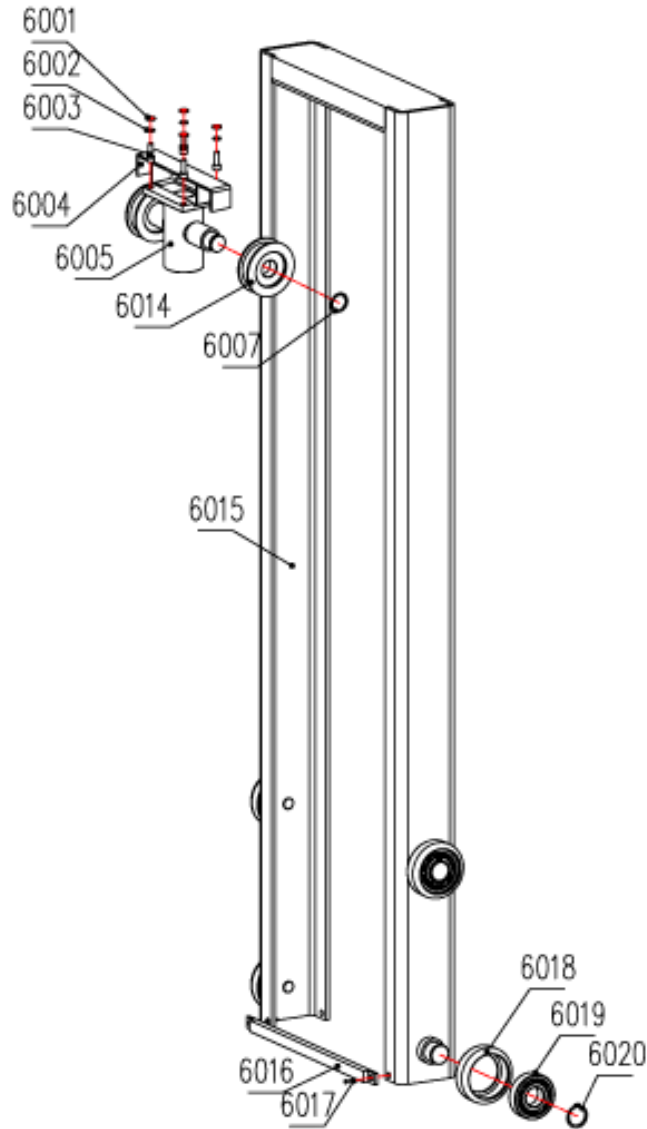

Figure 3:

Inner Mast PPS2200-150AS



Item	Description	Qty	Item	Description	Qty
6001	Flat Washer 8	4	6015	Inner Mast Weld	1
6002	Spring Washer 8	4	6016	Mast Bottom Beam	1
6003	Bolt M8X25 M10	4	6017	Bolt M10x25	2
6004	Chain Wheel Protect Plate	1	6018	Idler Wheel Cover	4
6005	Chain Wheel Frame Weld	1	6019	Bearing 6307	4
6007	Snap Ring 30	2	6020	Snap Ring 35	4
6014	Chain Wheel (special Bearing)	2			

Figure 4:

Cylinder View

PPS2200-150AS

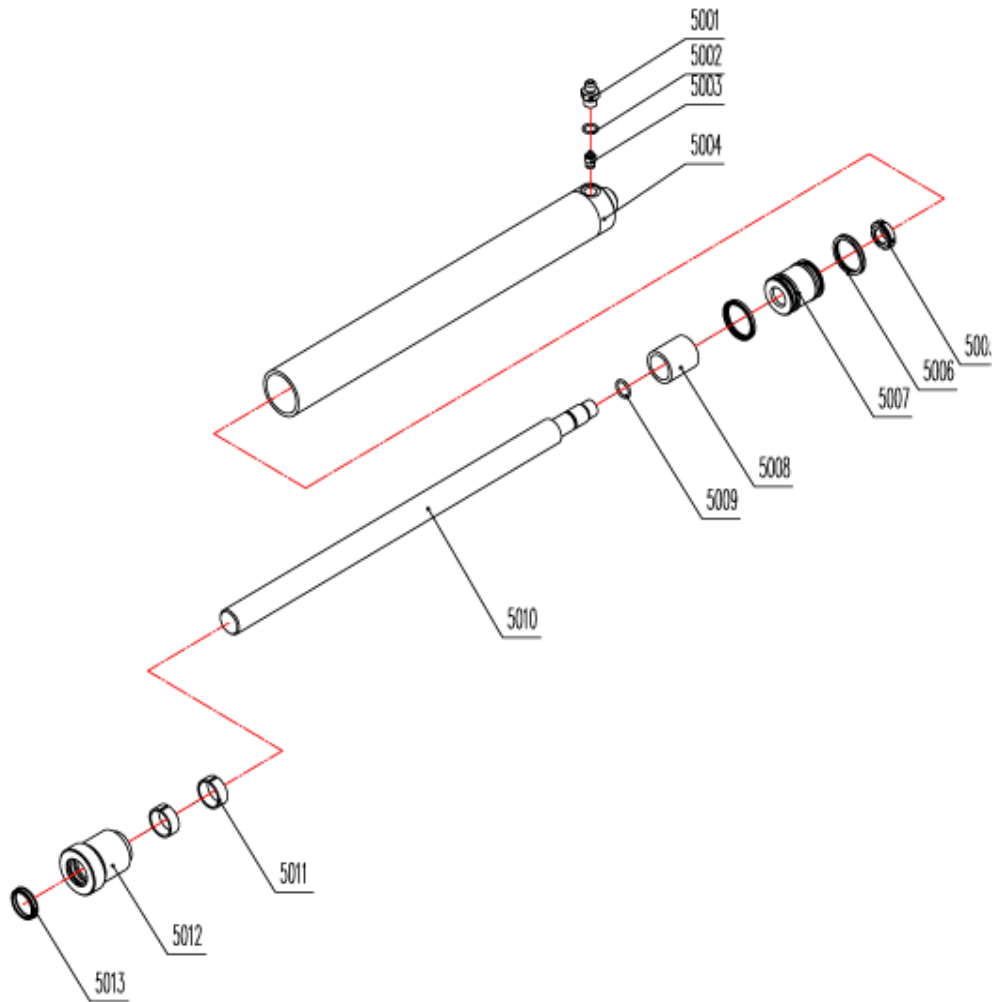

Item	Description	Qty
5001	Fitting	1
5002	O Ring	1
5003	Velocity Valve	1
5004	Cylinder Barrel	1
5005	Nut	1
5006	U Ring	2
5007	Piston	1
5008	Spacer	1
5009	O Ring	1
5010	Piston Rod	1
5011	Wearable Ring	2
5012	Direction Sleeve	1
5013	Dustproof Ring	1

Figure 5:

Caster Wheel Assembly PPS2200-150AS

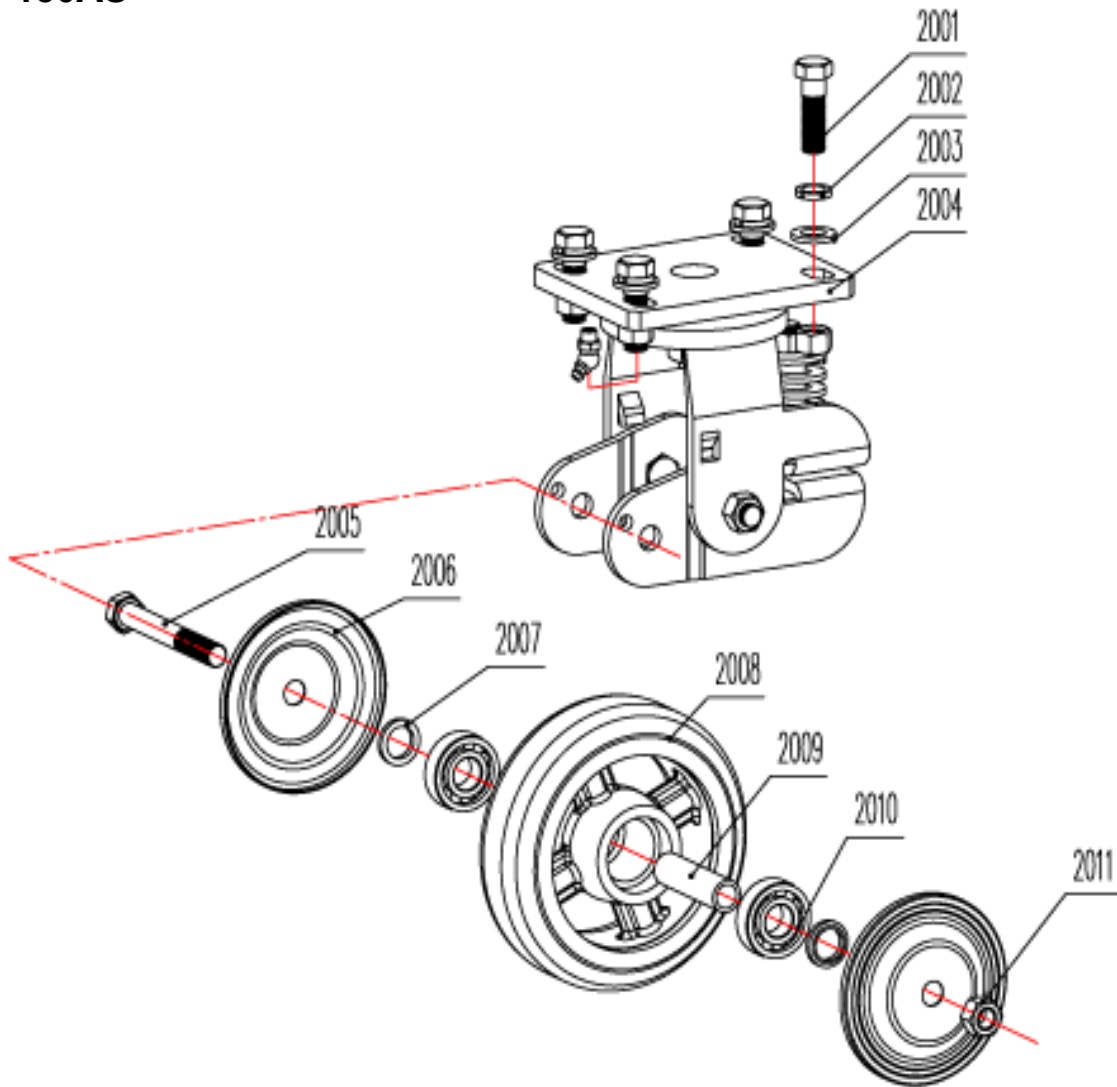

Item	Description	Qty
2001	Bolt M12X40	4
2002	Spring Washer M12	4
2003	Flat Washer M12	4
2004	Wheel Frame	1
2005	Bolt M12X90	1
2006	Wheel Side Cover	2
2007	Bearing Ring	2
2008	Wheel	1
2009	Sleeve	1
2010	Bearing	2
2011	Nut M12X90	1

Figure 6:

Drive Wheel Assembly PPS2200-150AS

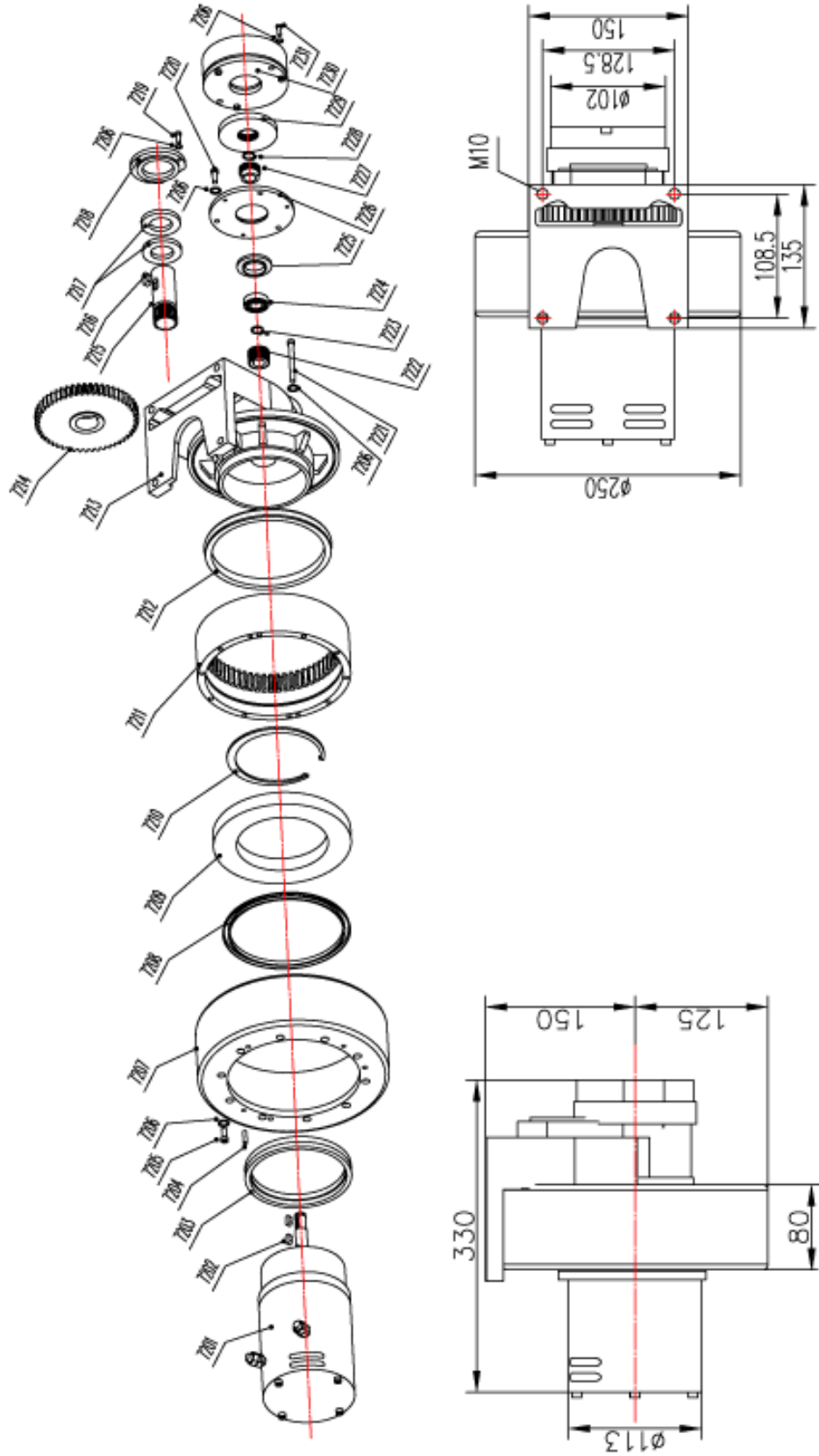
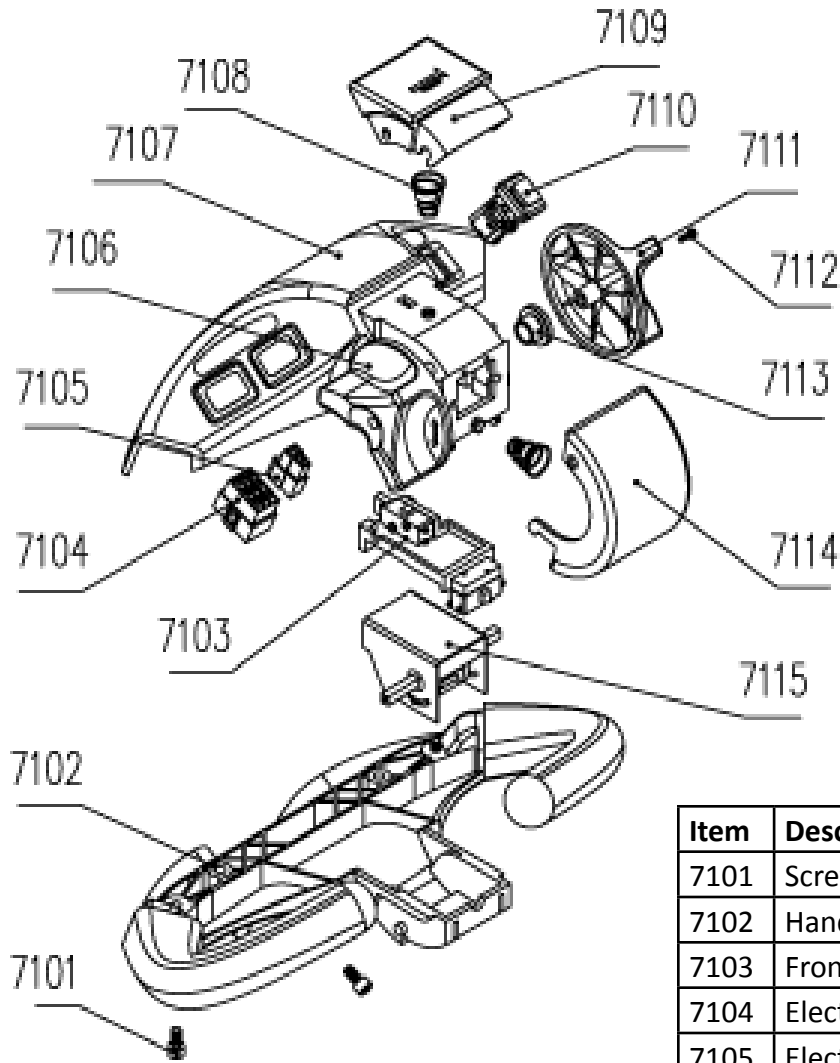

Figure 7:
Control Pod
PPS2200-150AS



Item	Description	Qty
7101	Screw M6X12	3
7102	Handle Bottom Cover	1
7103	Front Button	1
7104	Electrical Outlet (big)	1
7105	Electrical Outlets (small)	1
7106	Left Handle Cover	1
7107	Upper Cover	1
7108	Spring	2
7109	Horn Button	1
7110	Button Group	1
7111	Right Handle Cover	1
7112	Bolt M3X10	2
7113	Washer	2
7114	Switch Cover	1
7115	Switch	1

Figure 8:

Steering Assembly PPS2200-150AS

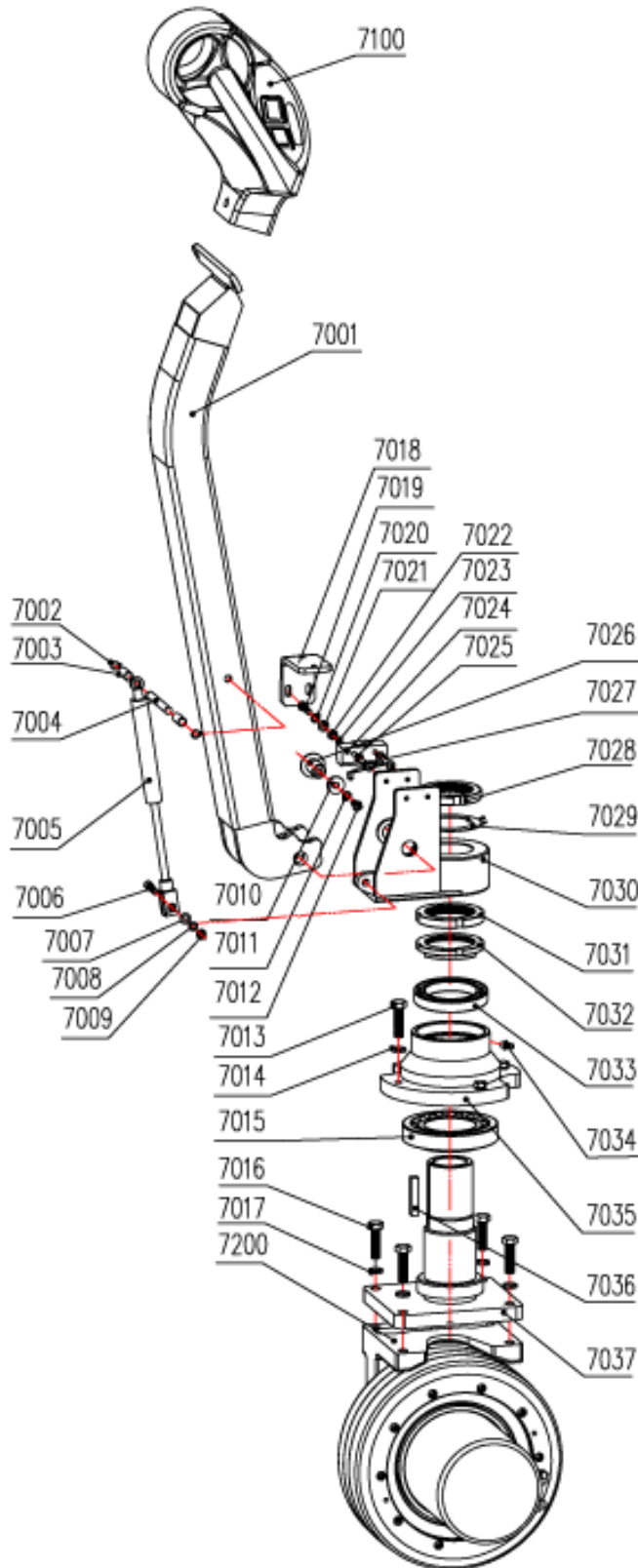

Item	Description	Qty
7100	Handle	1
7001	Handle Pipe Weld	1
7002	Snap Ring 8	1
7003	Holder	2
7004	Pin	1
7005	Air Spring Bearing	1
7006	Bolt M8X30	1
7007	Flat Washer 8	1
7008	Spring Washer 8	1
7009	Nut M8	1
7010	Washer	2
7011	Spring Washer 6	2
7012	Bolt M6X12	2
7013	Bolt M10X30	4
7014	Spring Washer 10	4
7015	Bearing 33013	1
7016	Bolt M10X30	4
7017	Spring Washer 10	4
7200	Drive Wheel (700W)	1
7018	Cover Holder	1
7019	Bolt M6X25	2
7020	Spring Washer 6	2
7021	Flat Washer 6	2
7022	Nut M6	2
7023	Nut M4	2
7024	Travel Switch	1
7025	Flat Washer 4	2
7026	Short Screw	2
7027	Bolt M4X25	2
7028	Round Nut M52X1.5	1
7029	Lock Washer 52	1
7030	Handle Connect Base	1
7031	Round Nut M56X2	1
7032	Washer	1
7033	Bearing 61812	1
7034	Oil Fitting M8X1	1
7035	Drive Wheel Holder	1
7036	A-Flat Key 8X45	1
7037	Steering Base Weld	1

Figure 9:

Power Unit Assembly PPS2200-150AS

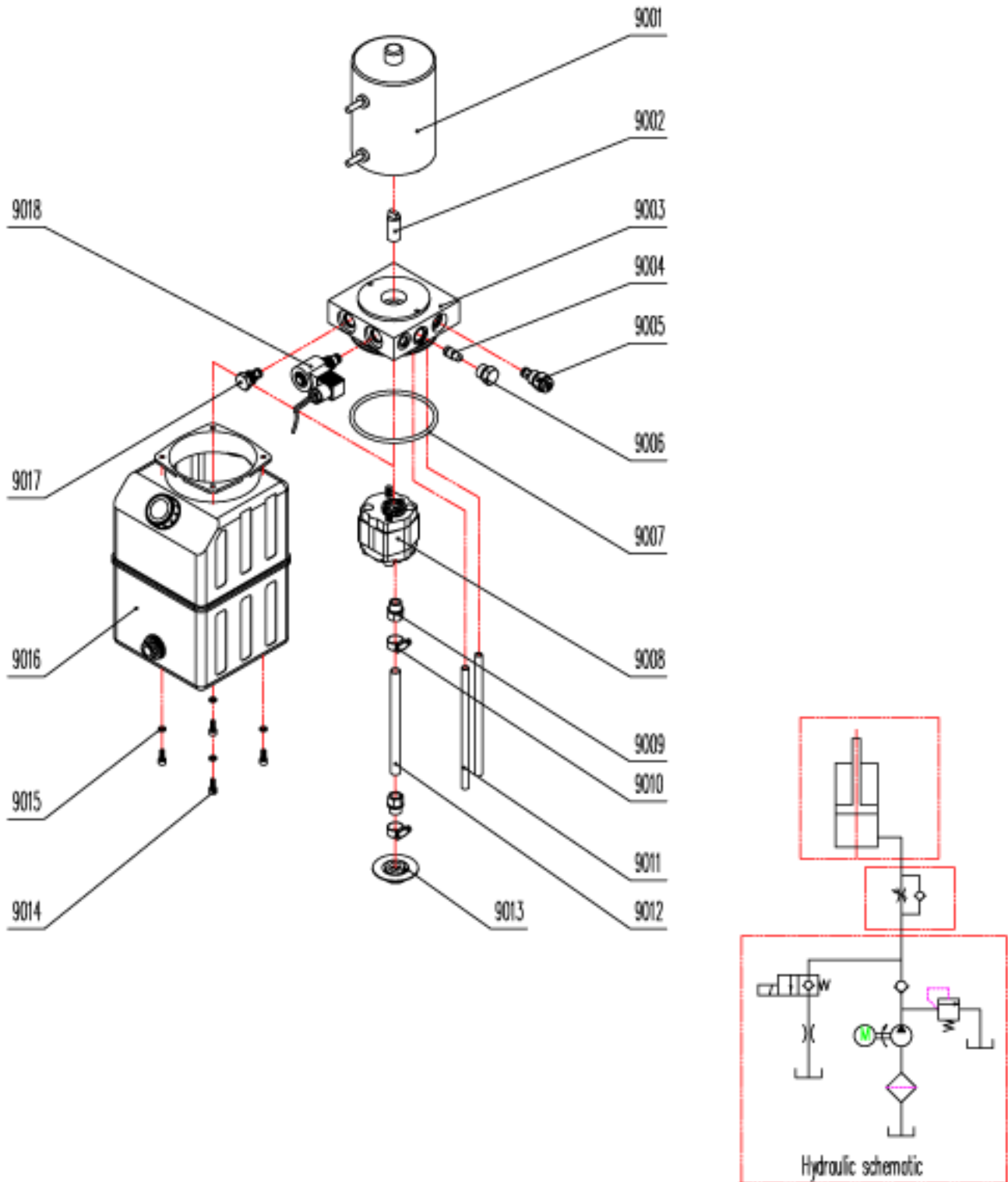
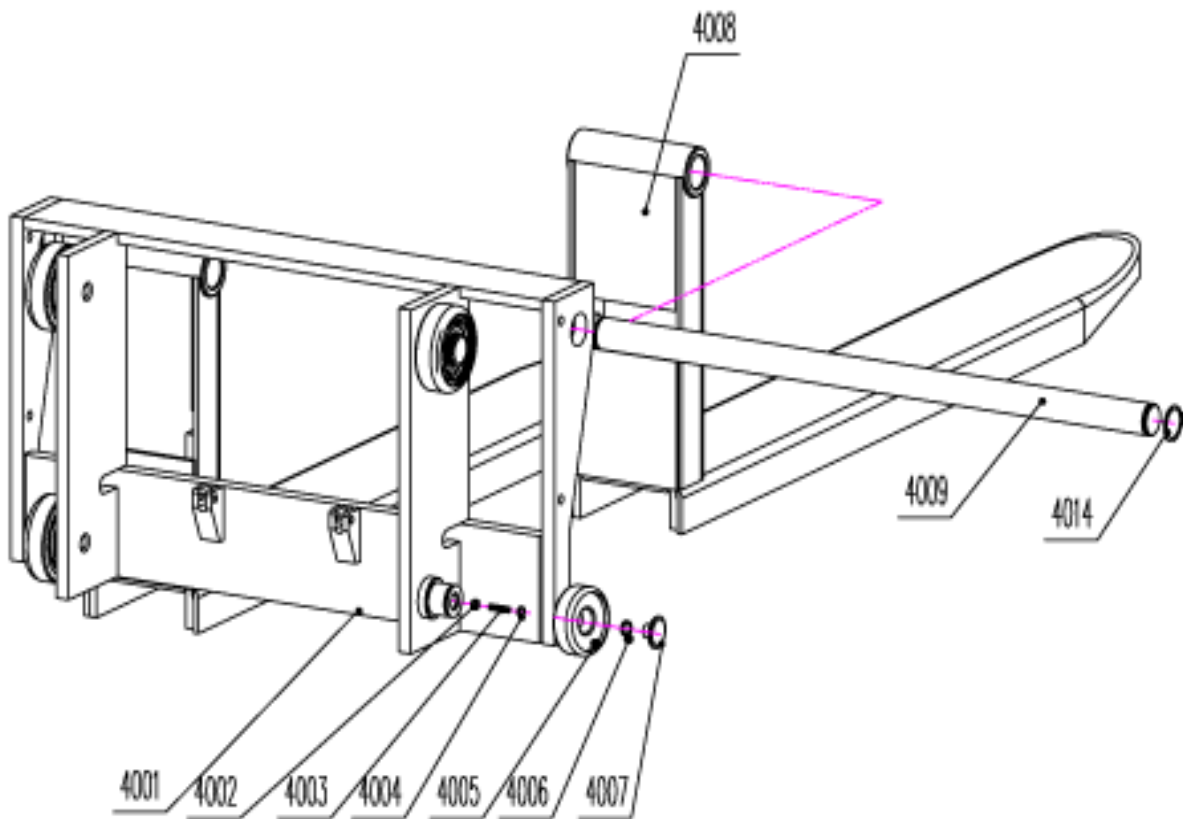

Figure 10:

Carriage Assembly PPS2200-150AS



Item	Description	Qty
4001	Lift Frame	1
4002	Nut M6	4
4003	Bolt M6X30	4
4004	Middle Plate	4
4005	Idler Wheel	4
4006	Adjustable Plate	4
4007	Wheel Sleeve	4
4008	Fork	2
4009	Fork Shaft	1
4014	Snap Ring 35	2

Figure 11: Labels & Precautionary Warnings

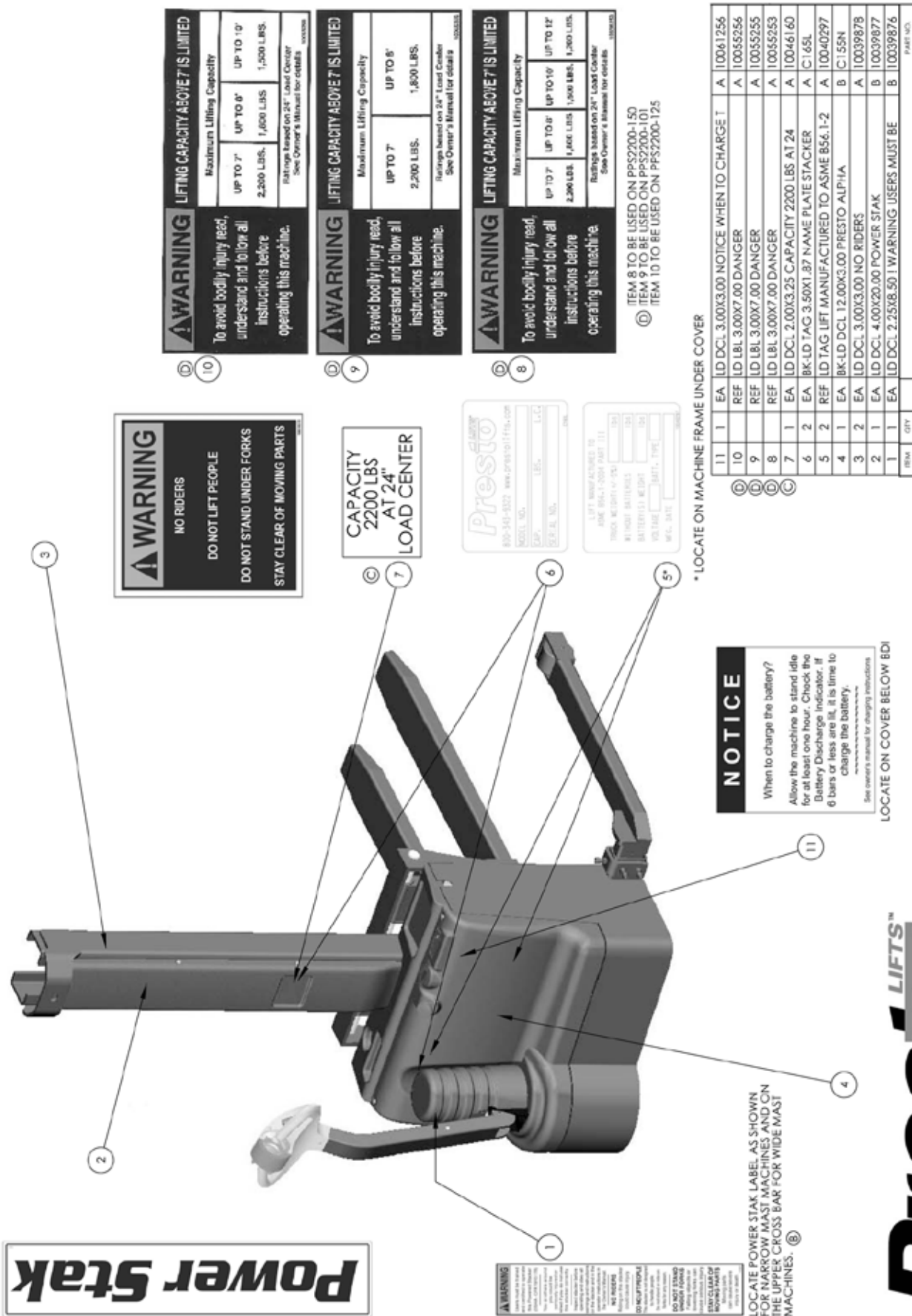

WARNING
NO RIDERS
DO NOT LIFT PEOPLE
DO NOT STAND UNDER FORKS
STAY CLEAR OF MOVING PARTS

**CAPACITY
2200 LBS
AT 24"
LOAD CENTER**

Presto
800-501-8322 www.presto1fr.com
MODEL NO. _____
SERIAL NO. _____
DATE _____
L.C.G. _____

LIFT INFO ATTACHED TO
FRAME IDENTIFY THE
TRUCK WEIGHT (W/ FORK)
WITHOUT BATTERIES
BATTERIES WEIGHT
WEIGHT (W/ BATT.) TYPE
W.C. DATE

* LOCATE ON MACHINE FRAME UNDER COVER

NOTICE
When to charge the battery?
Allow the machine to stand idle
for at least one hour. Check the
Battery Discharge Indicator. If
6 bars or less are lit, it is time to
charge the battery.
See owner's manual for charging instructions.

LOCATE ON COVER BELOW BDI

WARNING
LIFTING CAPACITY ABOVE 7' IS LIMITED
Maximum Lifting Capacity
UP TO 7' 2,200 LBS. 1,600 LBS.
UP TO 8' 1,600 LBS. 1,500 LBS.
UP TO 10' 1,500 LBS.
Ratings based on 24" Load Center
See Owner's Manual for details.

WARNING
LIFTING CAPACITY ABOVE 7' IS LIMITED
Maximum Lifting Capacity
UP TO 7' 2,200 LBS. 1,800 LBS.
UP TO 8' 1,800 LBS.
Ratings based on 24" Load Center
See Owner's Manual for details.

WARNING
LIFTING CAPACITY ABOVE 7' IS LIMITED
Maximum Lifting Capacity
UP TO 7' 2,200 LBS. 1,600 LBS. 1,200 LBS.
UP TO 8' 1,600 LBS. 1,500 LBS. 1,200 LBS.
UP TO 10' 1,500 LBS. 1,200 LBS.
Ratings based on 24" Load Center
See Owner's Manual for details.

ITEM 8 TO BE USED ON PPS2200-150
ITEM 9 TO BE USED ON PPS2200-101
ITEM 10 TO BE USED ON PPS2200-125

ITEM	QTY	PART NO.
11	1	EA. LD DCL 3.00X3.00 NOTICE WHEN TO CHARGE T
10	1	REF. LD LBL 3.00X7.00 DANGER
9	1	REF. LD LBL 3.00X7.00 DANGER
8	1	REF. LD LBL 3.00X7.00 DANGER
7	1	EA. LD DCL 2.00X3.25 CAPACITY 2200 LBS AT 24
6	2	EA. BK-LD TAG 3.50X1.87 NAME PLATE STACKER
5	2	REF. LD TAG-LIFT MANUFACTURED TO ASME B56.1-2
4	1	EA. BK-LD DCL 12.00X3.00 PRESTO ALPHA
3	2	EA. LD DCL 3.00X3.00 NO RIDERS
2	1	EA. LD DCL 4.00X20.00 POWER STAK
1	1	EA. LD DCL 2.25X8.50 1 WARNING USERS MUST BE

Presto
LIFTS™

LOCATE POWER STAK LABEL AS SHOWN
FOR NARROW MAST MACHINES AND ON
THE UPPER CROSS BAR FOR WIDE MAST
MACHINES. ⑧

Figure 12: Electric Control Parts

Prior to November 2008

Electric Control Parts

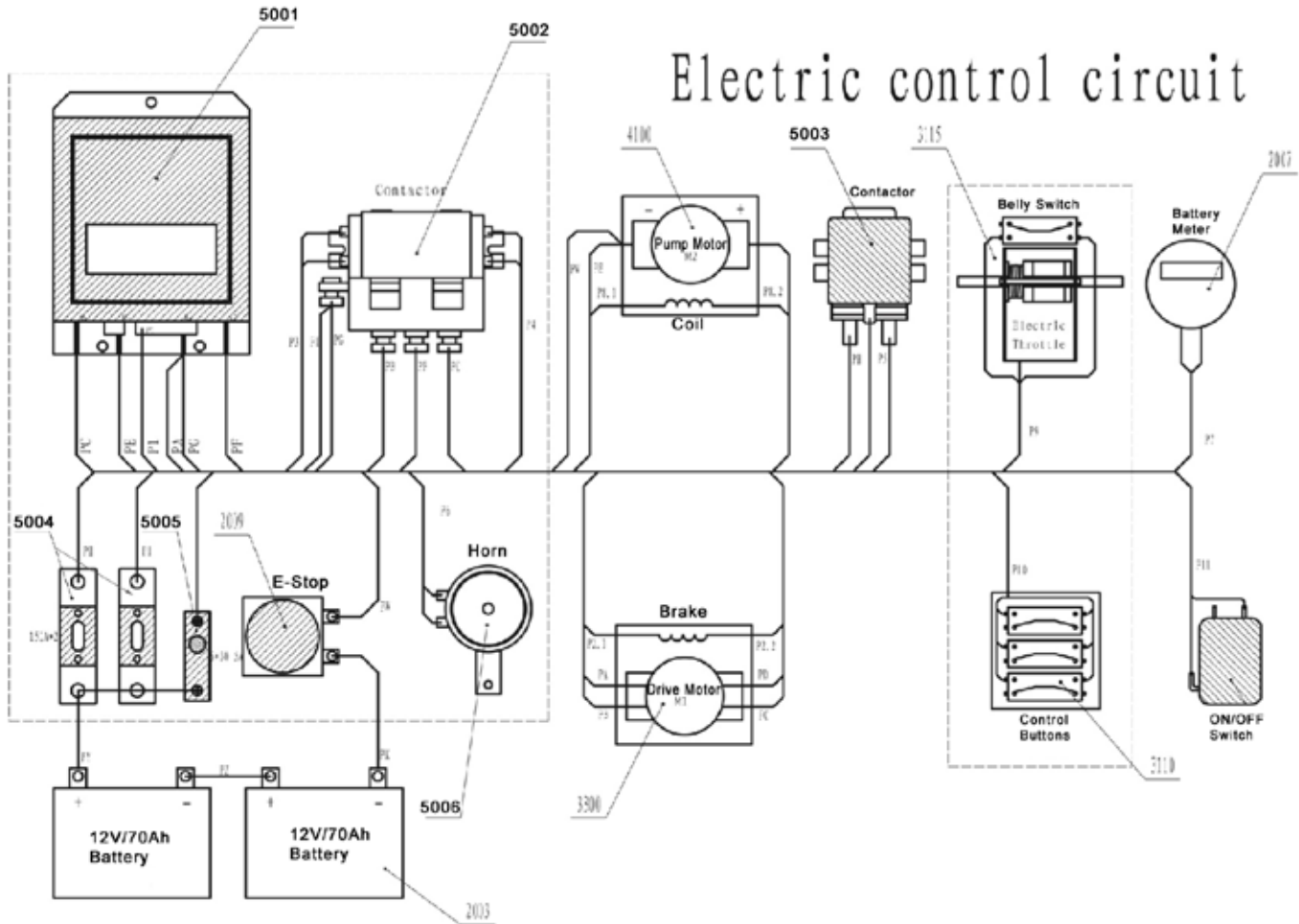

5001	MOSFET controller	1
5002	Contactor F/R	1
5003	Hydraulic Contactor	1
5004	Fuse 150A	2
5005	Fuse 5A	1
5006	Horn	1

Figure 13: Electric Control Circuit

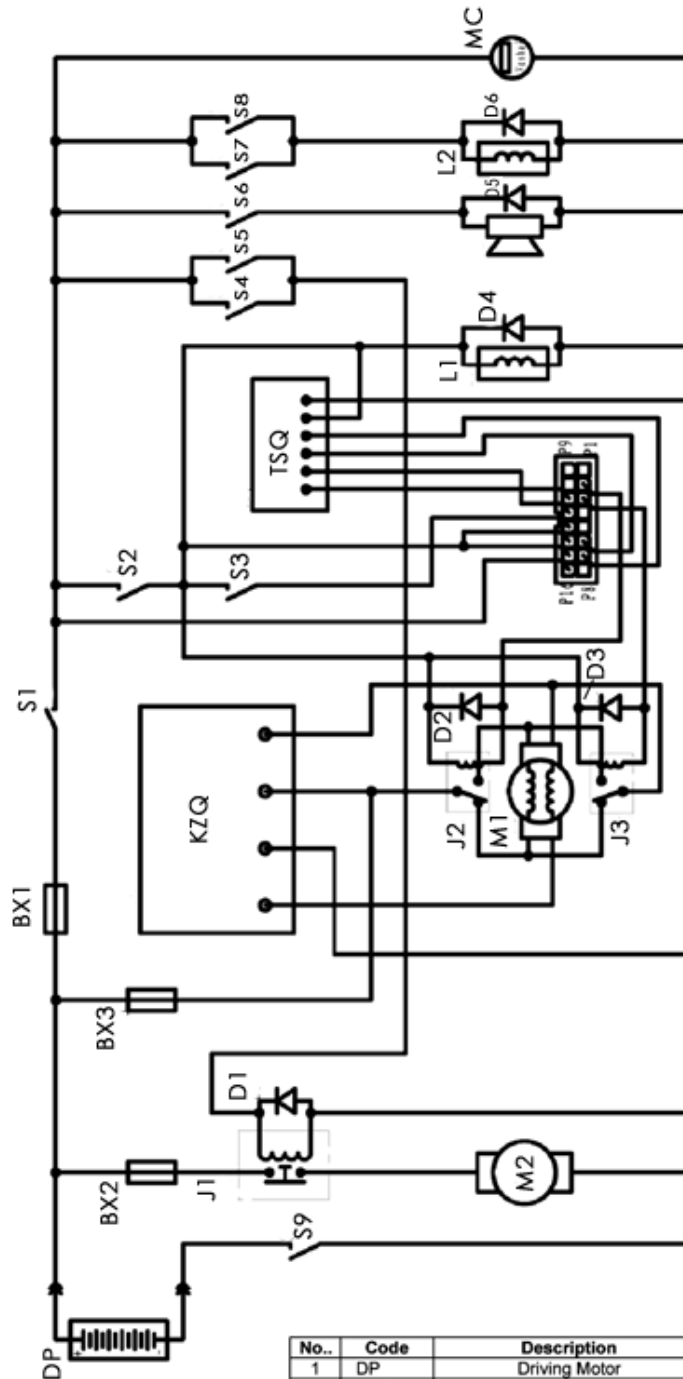

Electric Control Circuit

Prior to November 2008

No..	Code	Description	Model
1	DP	Driving Motor	12V/70Ah
2	KZQ	Motor Controller	1207A-4102, DC24V/250A
3	M1	Driving Motor	DC24V/0.7Kw
4	M2	Pump Motor	DC24V/1.3Kw
5	J1	Pump Motor Controller	DC24V/200A
6	J2, J3	Driving Motor Contactor	DC88-I, DC24V/24A
7	BX1	Driving Motor Fuse	DC24V/150A
8	BX2	Pump Circuit Fuse	DC24V/150A
9	BX3	Controller Circuit Fuse	FS-10 DC24V/10A
10	S2	Magnetic Clutch	
11	S3	Urgent Reverse Switch	
12	S4, S5	Up/Down Switch	
13	S6	Horn Switch	
14	S7, S8	Down Switch	
15	S9	Power Switch	250A
16	L1	Magnetic Clutch	DC24V/25W, 8N.m
17	L2	Magnetic Commutate Valve Circle	DC 24V/16W
18	D1	Diode	IN5408
19	MC	Battery Meter	DC24V
20	D2-D6	Diode	IN4007
21	TSQ	Timing	ETR711, DC24V

Figure 14: Wiring
Connectors viewed from wire entry side.

Prior to November 2008

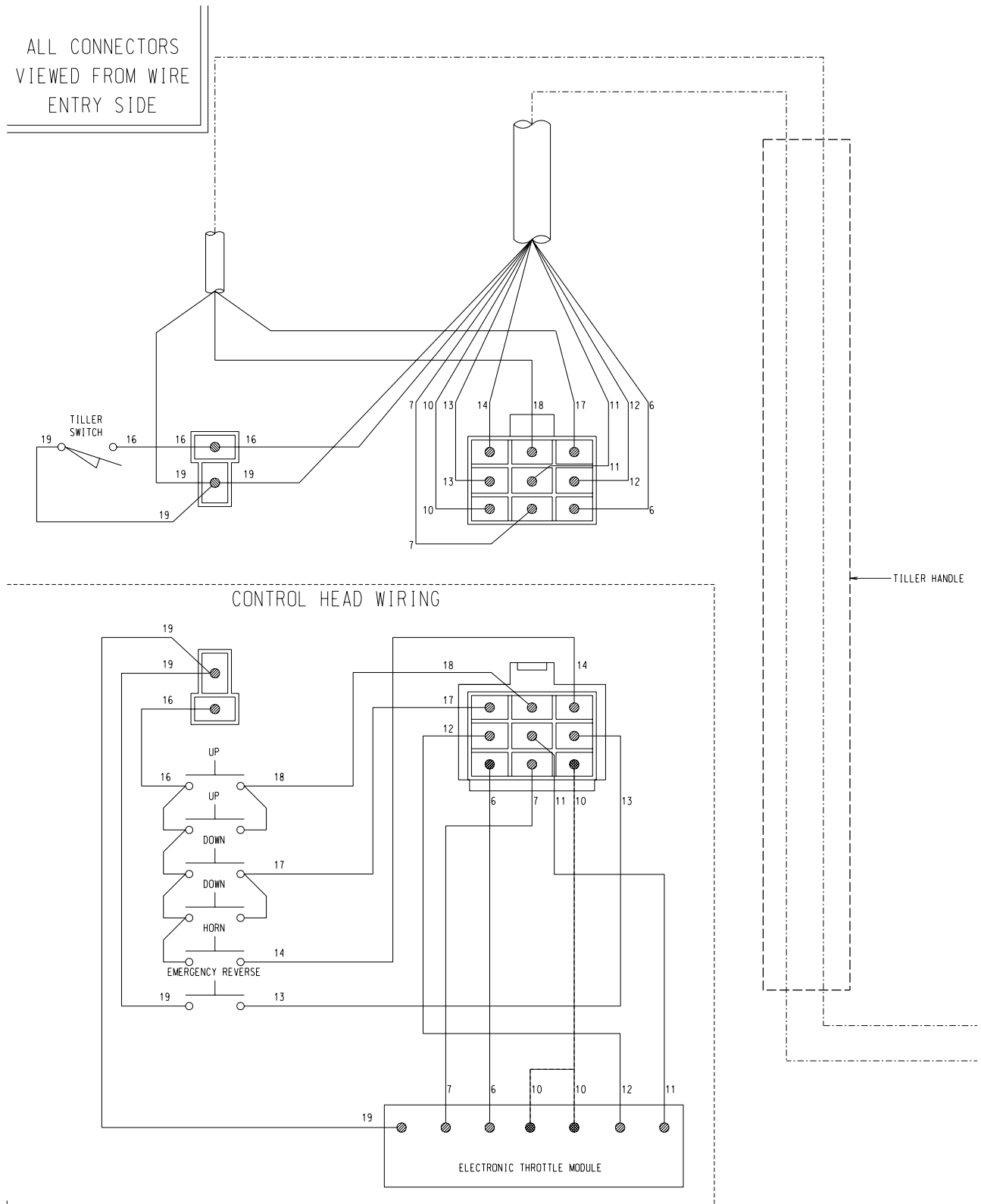

Figure 15:

Prior to November 2008

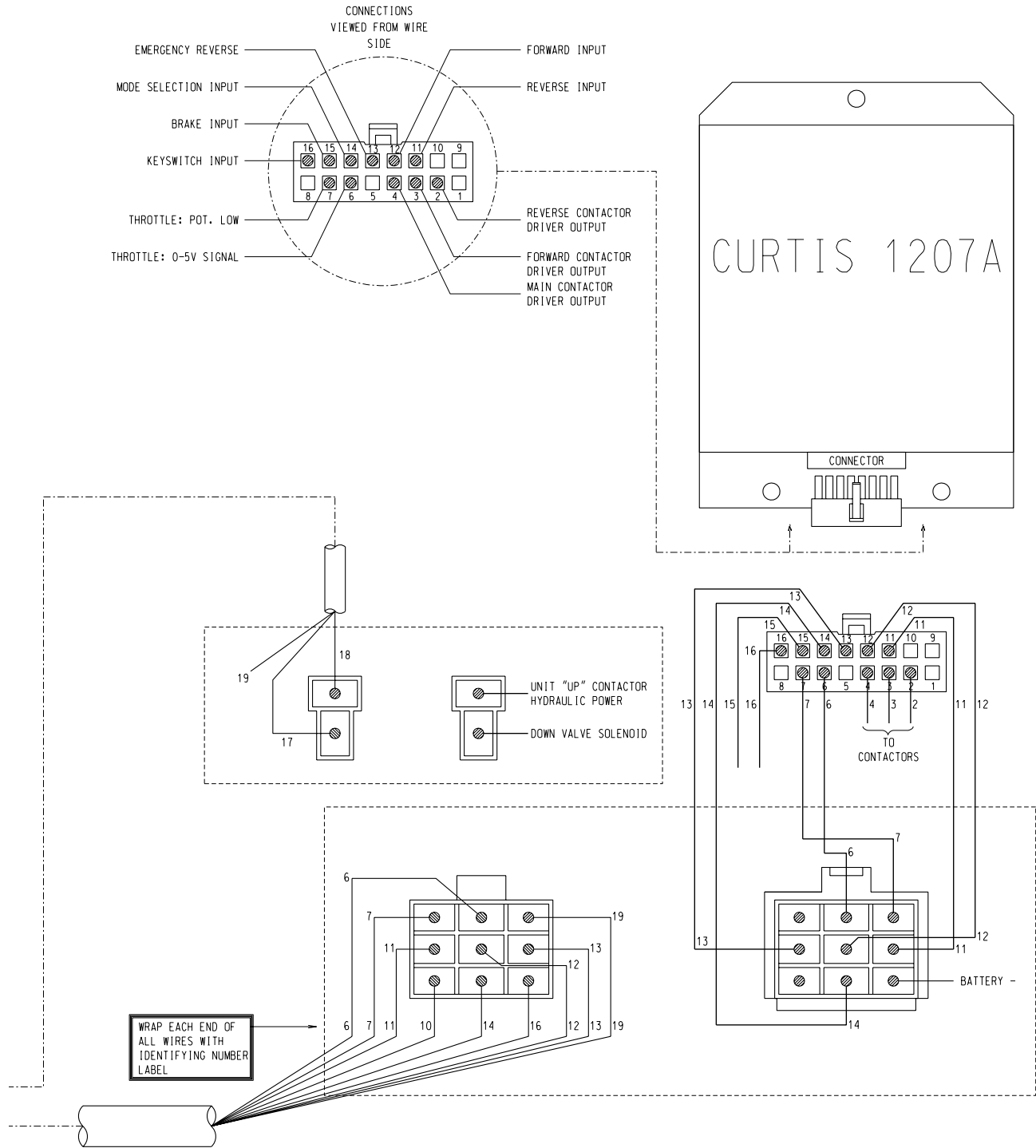

Figure 16:

November 2008 to Present

A- 80004302

REV	DESCRIPTION	DATE	APPROVED	MF ND.

NOTES:
 DIAGRAMS FOR POWERSTAKS WITH SERIAL #'S OF 080602 AND HIGHER,
 (LARGE FLAT BLADE CONNECTORS.)

ITEM	QTY	DESCRIPTION	PART NO.
7	REF	EL CONN DIAG PWRSTK WIRE HARNESS	B 80004290
6	REF	EL CONN DIAG PWRSTK WIRE HARNESS	B 80004289
5	REF	EL CONN DIAG PWRSTK WIRE HARNESS	B 80004288
4	REF	EL CONN DIAG PWRSTK FUEL GA & KEY SW	B 80004287
3	REF	EL CONN DIAG PWRSTK WIRE HARNESS	B 80004286
2	REF	EL CONN DIAG PWRSTK WIRE HARNESS	B 80004285
1	REF	EL CONN DIAG PWRSTK CTRL HEAD	B 80004284

 3RD ANGLE PROJECTION	FRACTIONS ±1/ .XXX ±.005 .XX ±.01 ANGLES ±.5°
	UNLESS OTHERWISE SPECIFIED, DIM ARE IN INCHES

PRESTO LIFTS 21 Park Street, Attleboro, MA 02703	WORLDWIDE MATERIAL HANDLING AND ERGONOMIC SOLUTIONS	DR DATE 10-23-08 CK DATE MFG DATE
REFERENCE 80004301	SCALE 3/4	PART NO.
MODEL TITLE EL ARR POWERSTAK (STD)	80004302	A
USE OF PROPRIETARY INFORMATION LIMITED TO WRITTEN AGREEMENT	A-DRAWING NUMBER	REV

THIS DRAWING MUST BE AT REVISION: 'A'

B- 80004294

Figure 18:

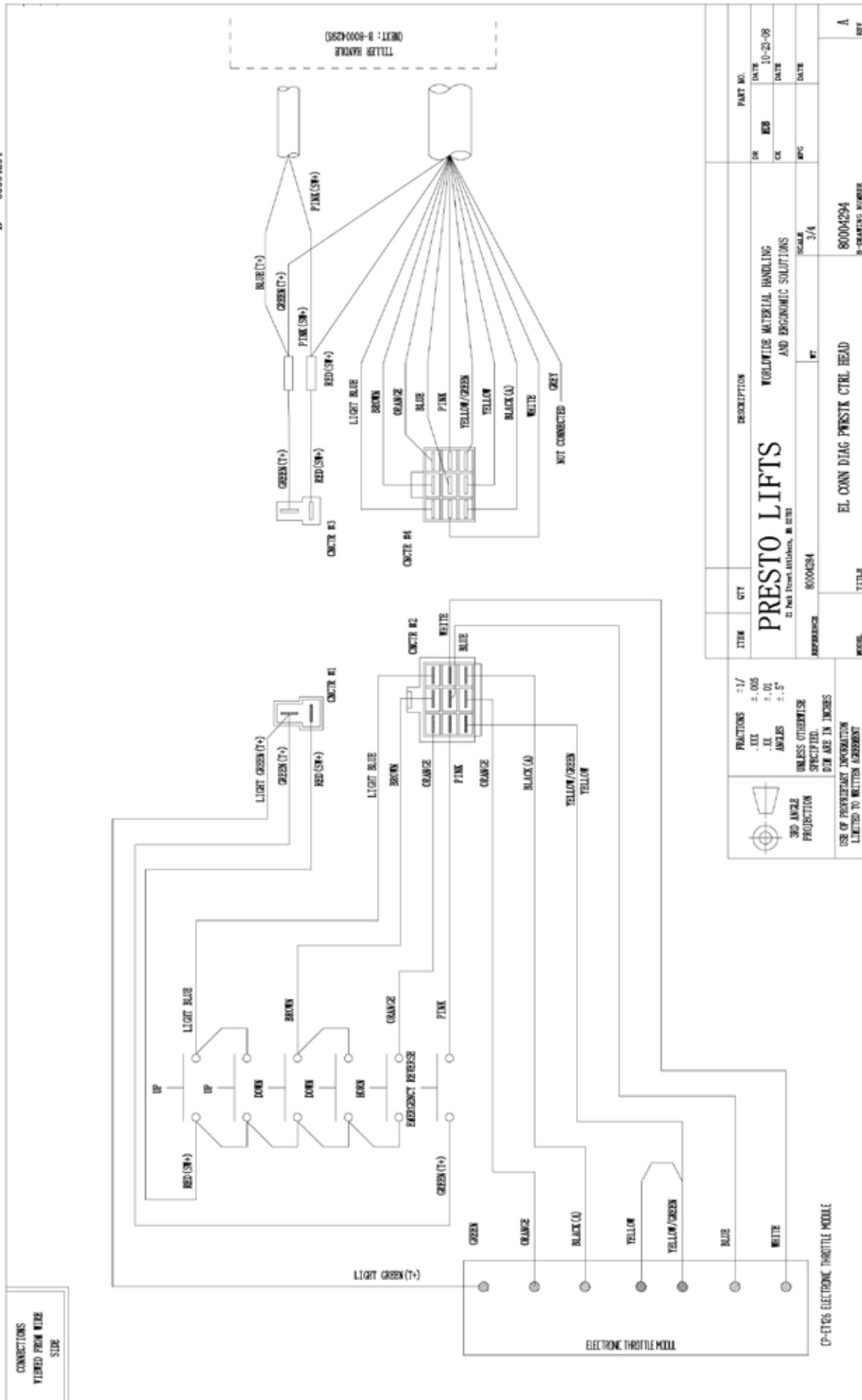

ITEM	QTY	DESCRIPTION	PART NO.
PRESTO LIFTS		WORLDWIDE MATERIAL HANDLING AND ERGONOMIC SOLUTIONS	DR DATE 10-23-09
80004294		EL CONN DIAG PRESTIK CTRL HEAD	CK DATE
			MPG DATE
			SCALE 3/4
			WT
			80004294
			8-DRAWING NUMBER
			A
			REV

<p>3D ANGLE PROJECTION</p>	<p>FRACTIONS ±1/</p> <p>.X.X ±.005</p> <p>.X.X ±.01</p> <p>ANGLES ±.5°</p> <p>UNLESS OTHERWISE SPECIFIED, DIM ARE IN INCHES</p> <p>USE OF PROPRIETARY INFORMATION LIMITED TO WRITTEN AGREEMENT</p>
----------------------------	--

Figure 19:

November 2008 to Present

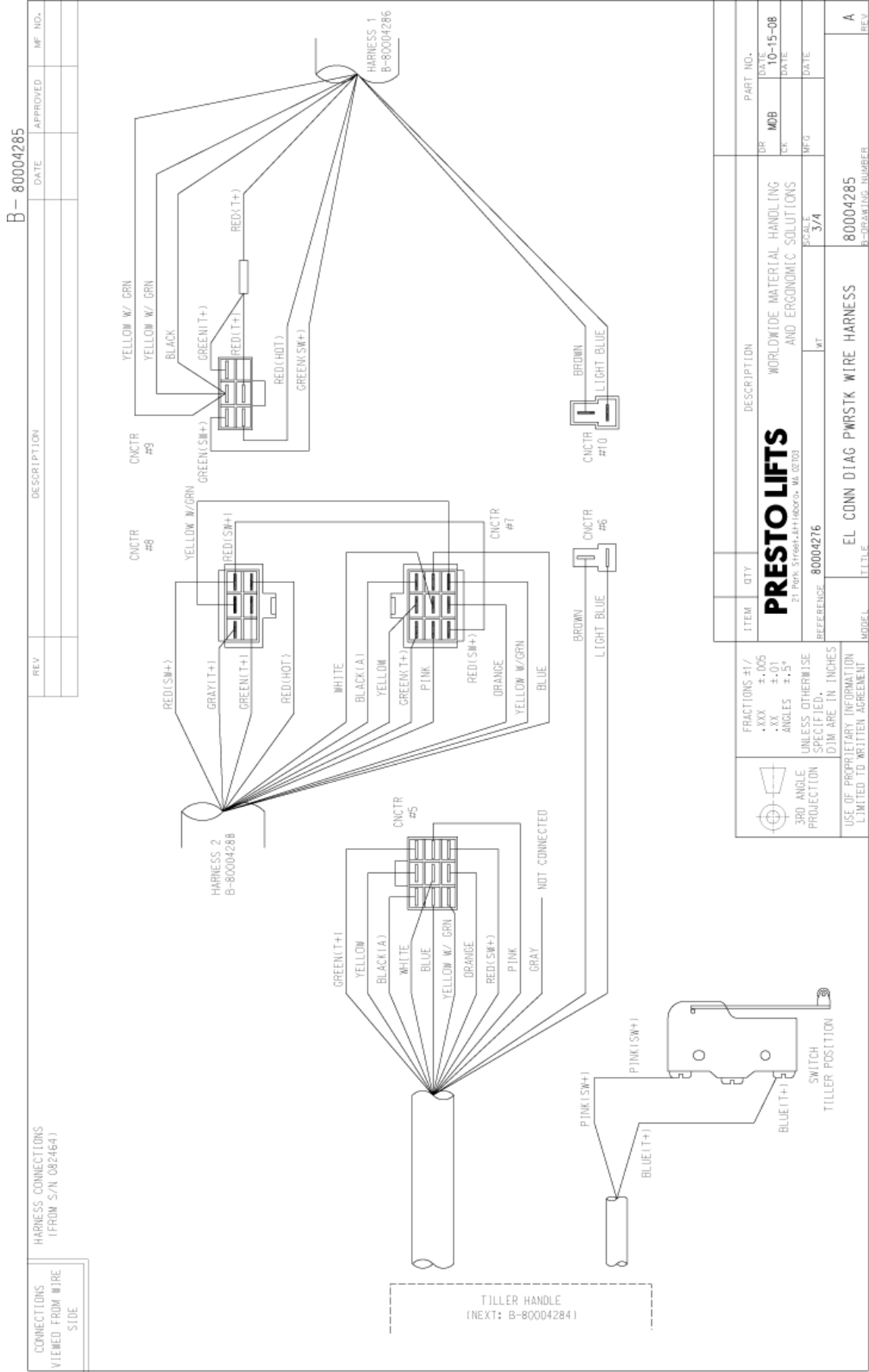
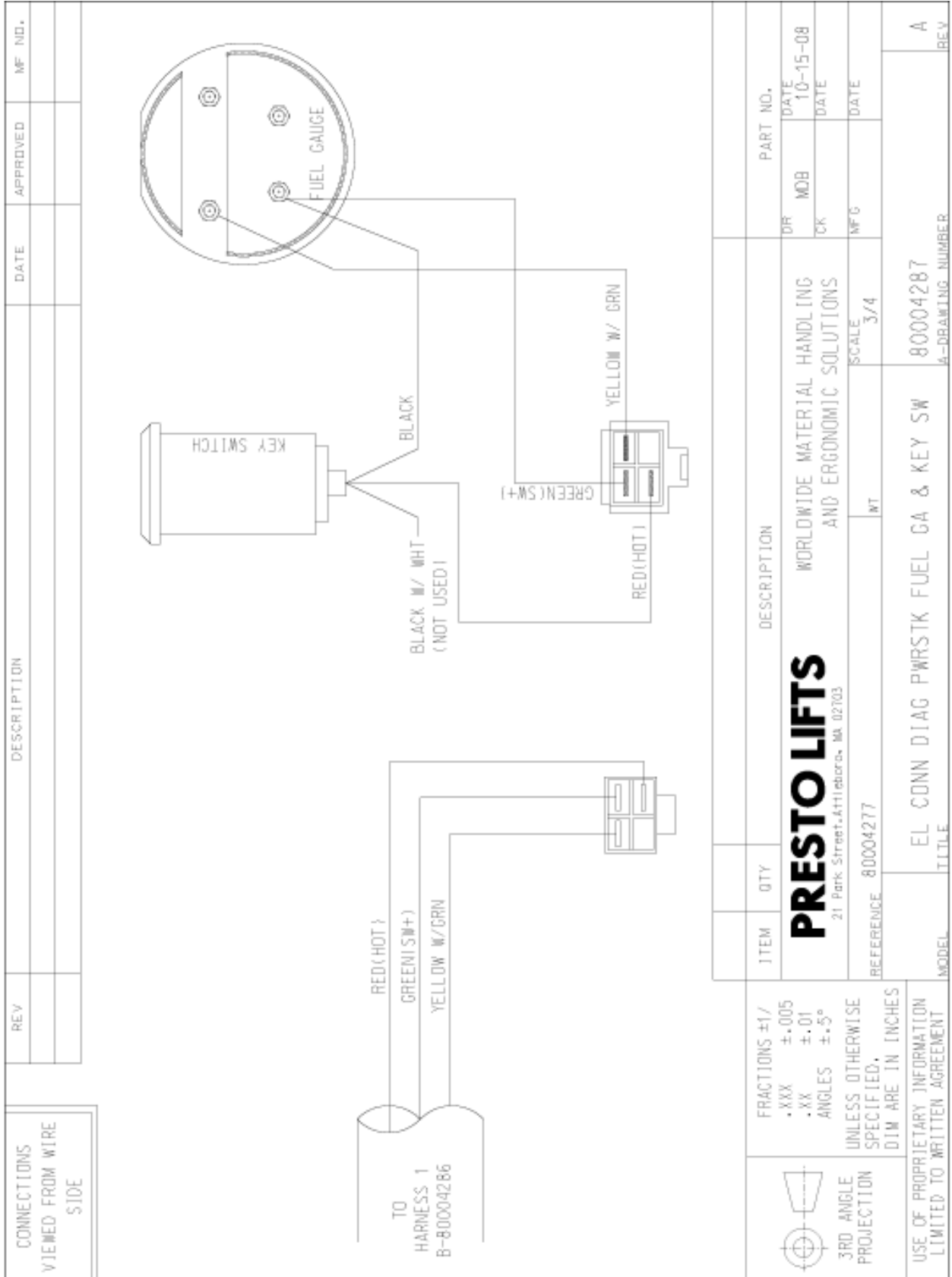

Figure 21:

November 2008 to Present

A - 80004287



CONNECTIONS VIEWED FROM WIRE SIDE	REV	DESCRIPTION	DATE	APPROVED	MF NO.

ITEM	QTY	DESCRIPTION	PART NO.
		PRESTO LIFTS 21 Park Street, Attleboro, MA 02703	DR DATE 10-15-08
		WORLDWIDE MATERIAL HANDLING AND ERGONOMIC SOLUTIONS	CK DATE
		SCALE 3/4	MPG DATE
		REFERENCE 80004277	
		MODEL TITLE EL CONN DIAG PWRSTK FUEL GA & KEY SW	
		80004287	
		4-DRAWING NUMBER	
			A
			REV

THIS DRAWING MUST BE AT REVISION: 'A'

Figure 22:

November 2008 to Present

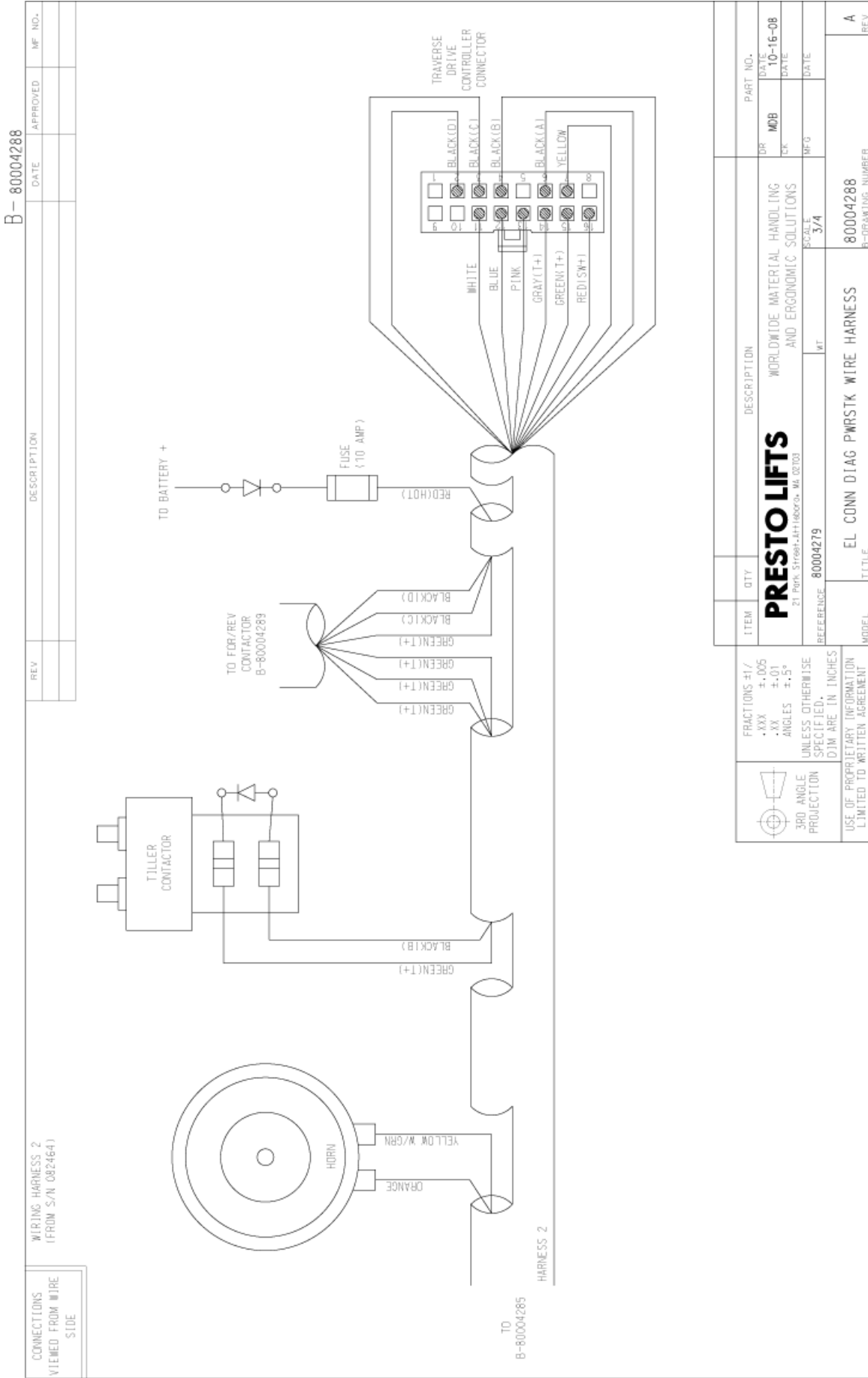

Figure 23:

November 2008 to Present

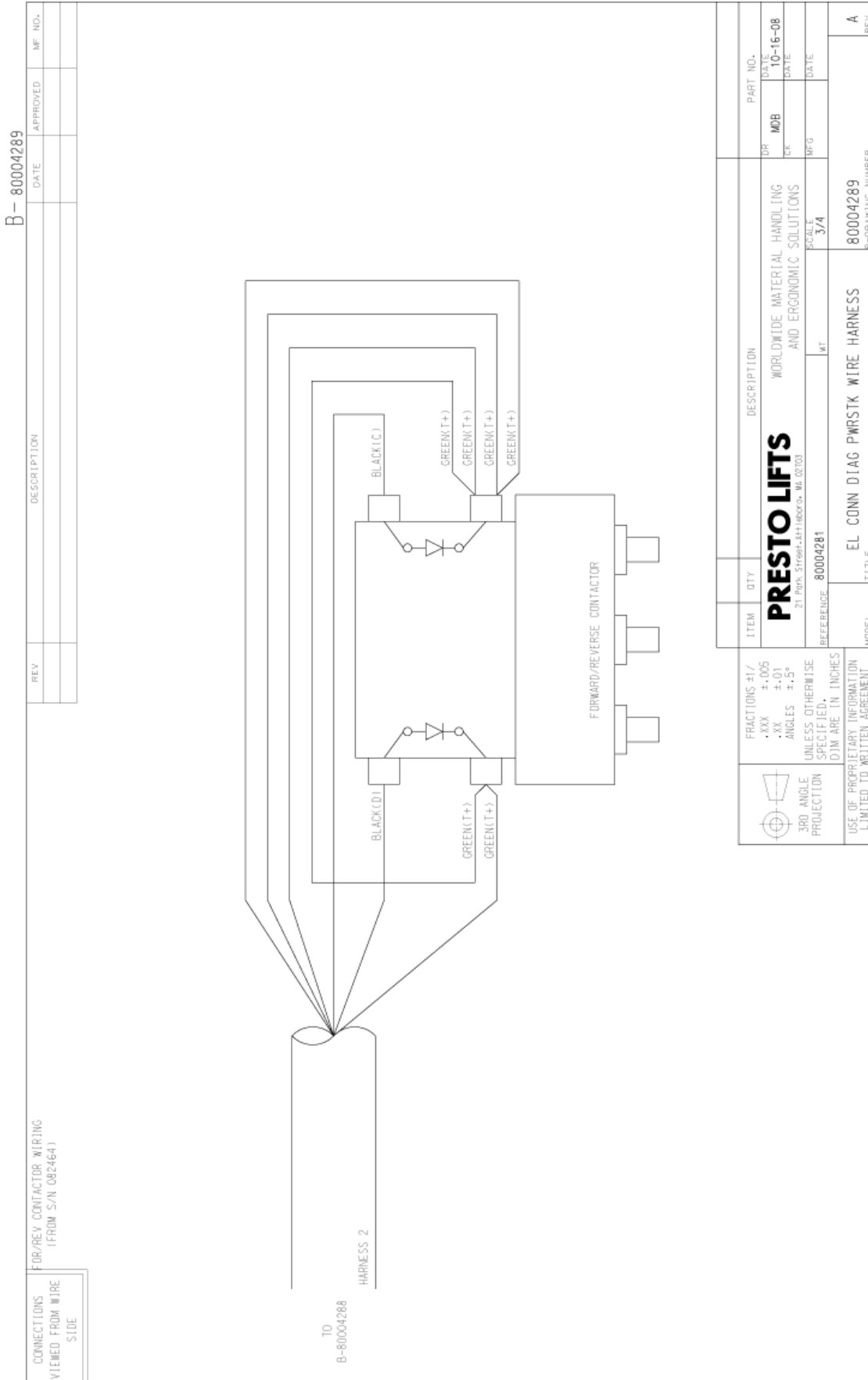
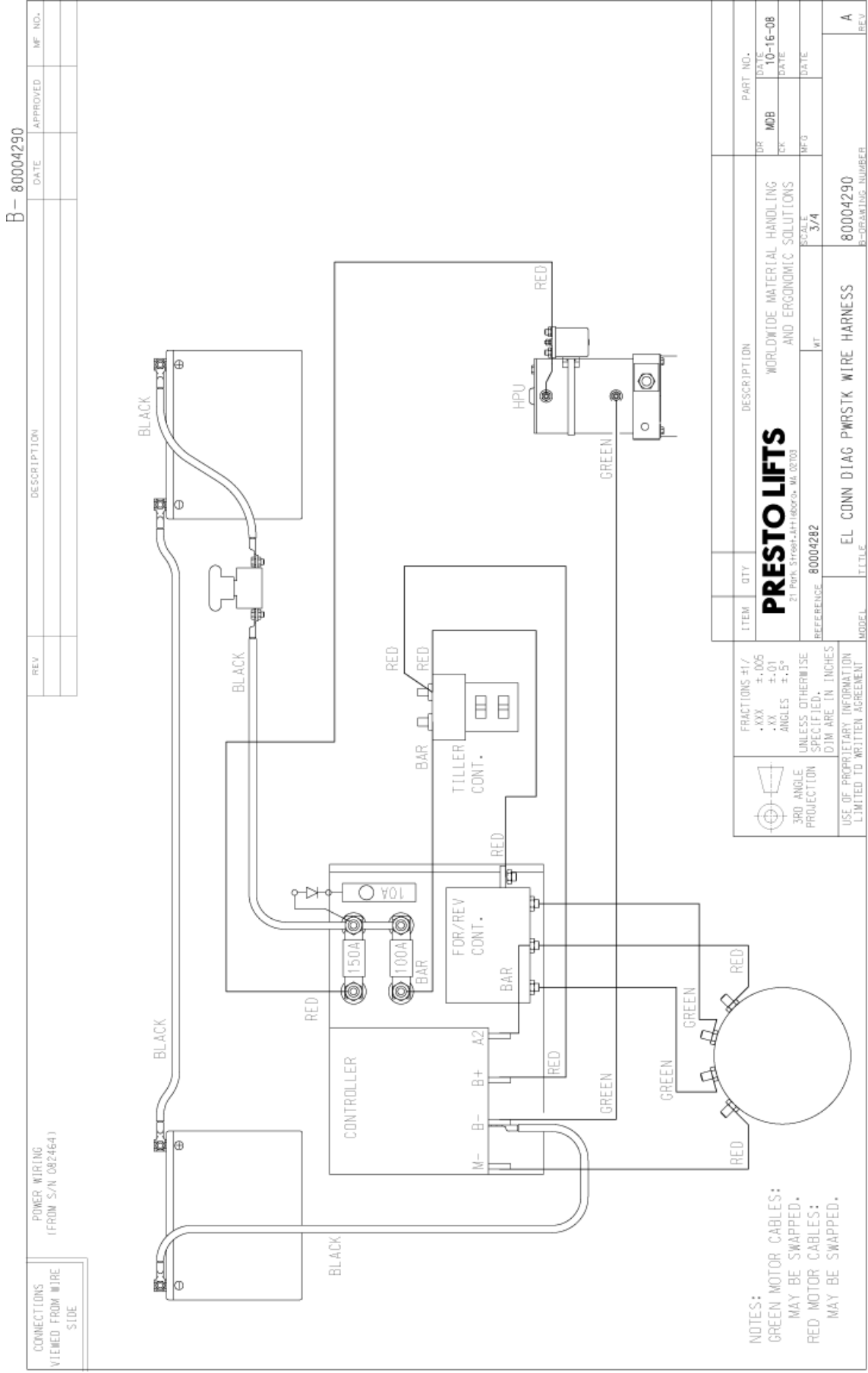

Figure 24:

November 2008 to Present



THIS DRAWING MUST BE AT REVISION: 'A'

RECOMMENDED SPARE PARTS LIST

PPS2200-150AS

Qty	Part No.	Description
1	80004251	Shock-air spring piston
1	PPS-1005	Limit Switch at handle
4	PPS-3110	Switch, raise/lower
1	PPS-3115	Switch, forward/reverse
1	PPS-5004	150A fuse (hydraulic power unit)
1	10049242	100A/125A fuse (Traverse)
1	PPS-5002	Forward/reverse contactor
1	PPS-5003	Contactor, main, for lift
1	PPS-2016	Battery charger
1	10039318	Battery charger cord
1	PPS-3030	Brake kit (Brake & Gear)
1	Serial number req.	Swivel caster assembly
2	PPS-AS/FS-2021	Load wheel axle
2	PPS-AS-FS-2023-2022	Load wheel with bearings

ORDERING REPLACEMENT PARTS

Presto Lifts has carefully chosen the components in your unit to be the best available for the purpose. Replacement parts should be identical to the original equipment. Presto Lifts will not be responsible for equipment failures resulting from the use of incorrect replacement parts or from unauthorized modifications to the unit.

Presto Lifts can supply all replacement parts for your lift. With your order, please include the model number and the serial number of the unit. You can find these numbers on the name plate. This plate is located within the cabinet, or the angle iron cylinder cross support.

To order replacement parts, please call the Presto Parts Department. Parts are shipped subject to the following terms:

- FOB factory
- Returns only with the approval of our Parts Department.
- Credit cards preferred (except parts covered by warranty).
- Freight collect for truck (except parts covered by warranty).
- Freight - prepaid and invoice for small parcel shipments (except parts covered by warranty).

Parts replaced under warranty are on a "charge-credit" basis. We will invoice you when we ship the replacement part, then credit you when you return the worn or damaged part.

Presto Lifts Parts Department
21 Park Street, Attleboro, MA 02703
Telephone: 800-343-9322
FAX: 888-788-6496
Email: Service@PrestoLifts.com
www.PrestoLifts.com

RESTOCKING POLICY

PARTS

Standard parts may be returned with a 20% restocking fee. Modified or custom-engineered parts are not returnable. Unfortunately, due to potentially concealed damage, all sales of electrical assemblies are final.

QUALITY ISSUES

Should you feel there is a quality problem, please contact the seller to ask questions and gather information on how to rectify the issue. Presto Lift Inc. reserves the right to determine potential credits, as a result of factory defects, based on its inspection of the merchandise.

GENERAL

All products shipped from our factory have passed Quality Assurance inspection and testing. The carrier of choice has signed for, and accepted the product in new working condition. The customer should inspect to ensure it is not received damaged, has no concealed damage or is not incomplete. Parts orders are determined to be complete based upon Presto Lift, Inc. inspection sheets and carrier shipping weights.

RETURN GOODS AUTHORIZATION POLICY

Presto Lifts provides the Return Goods Authorization (RGA) Policy, for specific models, as a courtesy to our distributors in the event they do not receive what they ordered. If a customer wishes to return a Presto Lifts product, please contact the Customer Service Department and request an RGA number. This request must be made on or before the fifteenth calendar day following the date of Presto Lifts' invoice for the merchandise. Not all units are returnable. Quantity orders and special designs cannot be returned under any circumstances. Presto Customer Service reserves the right for final judgment on all product returns.

The RGA number must appear on the outside of any packaging material for a return to be accepted and processed by Presto Lifts. Customers shipping returns from the Continental US, Canada, or Mexico have thirty (30) days from date of RGA issue to have the product arrive at Presto Lifts' facility. All merchandise must arrive Free on Board at Presto Lifts' facility or the shipment will be refused and returned to the sender. All credits are issued less restocking and refurbishing charges, regardless if the merchandise was damaged in transit.

Return addresses: please refer to your RMA for the address to which your product should be returned.

Presto Lift Inc.
715 Highway 77
Manila, Arkansas 72442

Telephone: 800-343-9322
Fax: 888-788-6496

MANY NEEDS REQUIRE MANY OPTIONS...

Presto LIFTS



LET PRESTO MEET THOSE NEEDS!

Call Presto Sales
for stock or
customized lift inquiries:
800-343-9322

Email: sales@prestolifts.com

