



Presto LIFTS™
worldwide material handling
and ergonomic solutions

Regal MV Series

Installation, Operation and Service Manual

Model Number _____

Serial # _____

Date placed in service _____

**IMPORTANT: READ CAREFULLY
BEFORE INSTALLING OR OPERATING LIFT**

Part orders are subject to a \$50 minimum charge.

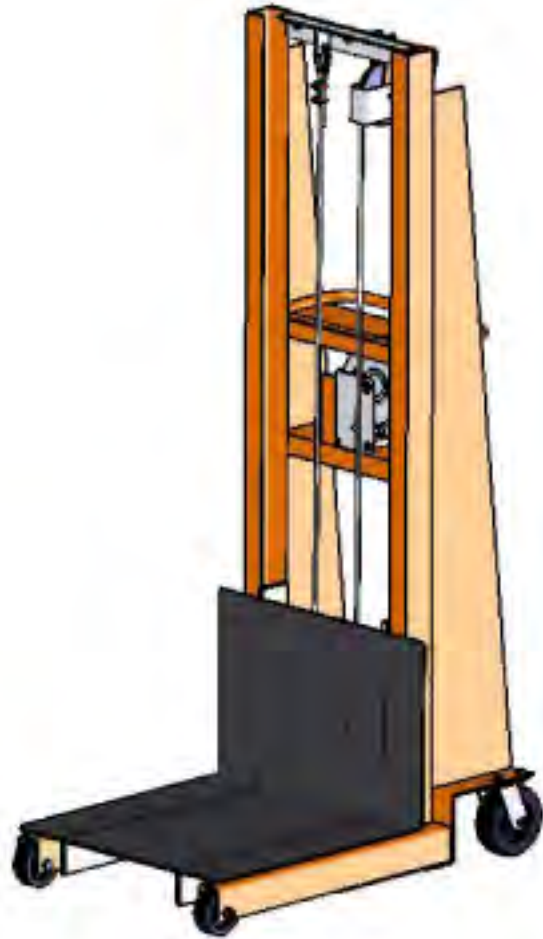
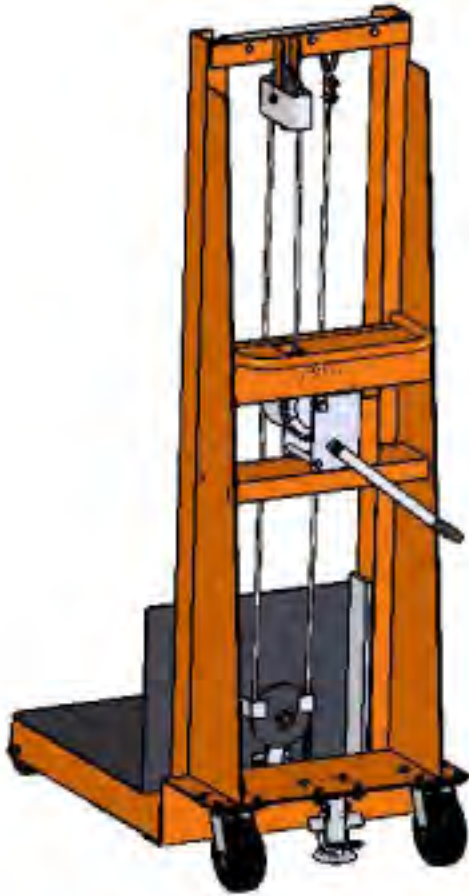

This manual was current at the time of printing. To obtain the latest, most updated version, please contact the Customer Service Department or go to our website: www.PrestoLifts.com -- you will find a complete list of current owner's manuals to print.

CONTENTS

SECTION 1:	
Introduction.....	4
SECTION 2:	
Safety	4
SECTION 3:	
Installation.....	4
SECTION 4:	
Operation.....	5
Operator's Responsibility for Maintenance.....	6
SECTION 5:	
Parts List	9
ORDER REPLACEMENT PARTS	12
RESTOCKING POLICY.....	13
RETURN GOODS AUTHORIZATION (RMA) PROCEDURES.....	14
WARRANTY	BACK COVER

LIST OF FIGURES:

Lubrication Points.....	6
Center Load.....	7
Parts.....	10

SECTION 1

INTRODUCTION

PURPOSE OF EQUIPMENT

The MV Series Stacker is designed to provide day-to-day lifting, stacking and handling of a wide variety of materials.

LIMITATIONS AND WARNINGS

Read and understand the Operator's Responsibility for Maintenance before using.

DANGER

- For use by trained authorized personnel only.
- Death or serious injury can result if shoplifter is not kept in good working order and is not used carefully.

CAUTION

- Do not use if MV Series Stacker is not working properly or any part is damaged or worn.
- Do not overload.
- Do not use on ramps and inclines.
- Do not use without floor lock pad securely locked against floor.
- Do not slide loads on or off platform without adequate bracing or blocking of MV Series Stacker.
- Do not drop loads on platform.
- Do not put hands, feet or any part of your body under platform.
- Do not move with platform raised.

OPERATOR QUALIFICATIONS

Only trained and authorized persons should use this MV Series Stacker. Safe use of this MV Series Stacker requires the operator to understand the limitations and warnings, operating procedures and operator's responsibility for maintenance. The operator must also understand all warnings and instructions on the MV Series Stacker. Operator also must be familiar with employer's work rules and relating government regulations.

DESCRIPTION

The MV Series Stacker is a handcrank mechanically operated push-around lift truck. The simply hoist unit is geared for precision leveling and load positioning. The ratchet and pawl hold the load at desired height.

CONTINUE ONLY IF YOU UNDERSTAND WHAT YOU HAVE JUST READ.

SECTION 2

SAFETY

OPERATOR SAFETY REMINDERS

The National Safety Council reminds us that most accidents are caused by the failure of some individuals to follow simple and fundamental safety rules and precautions. You, as a careful operator, are the best insurance against an accident. Therefore, proper usage of this machine is mandatory. The context of this manual should be read and understood completely before operating the machine. Any modifications from the original design are strictly forbidden without written permission from Presto Lifts, Inc.

WARNING!

- Do not perform any repair work on lifts if there is a load on the forks or platform.
- Do not perform any repair work if the forks or platform is in the raised position.
- All personnel must stand clear of the lift while in motion.
- Do not put hands or feet under the forks or platform.
- Do not stand underneath the forks or platform.
- Do not stand in front of the stacker while in motion.
- Do not stand, sit or climb on the lift.
- Do not use the lift on soft, uneven or unstable surfaces.
- Do not exceed the load center or capacity.

SECTION 3

INSTALLATION

SET UP PROCEDURE

Each MV Series Stacker has been thoroughly inspected and tested prior to shipment. Due to possible damage in transit, the following procedures must be performed before the equipment is used.

1. Remove all protective covering making certain that nothing has jammed or fallen into the moving parts of the truck.
 2. Inspect the MV Series Stacker for damage in shipment. Be sure to notify the trucking firm immediately if there is any damage.
 3. All MV Series Stackers are equipped with a foot operated floor lock. For shipment, it is mounted upside down above the rear swivel casters. Before using the machine, it should be mounted in position between the two swivel casters.
 4. Check condition of lubrication. If necessary, lubricate entire MV Series Stacker – see lubrication instructions.
 5. Check and test safety devices per MAINTENANCE section.
1. Maximum capacity for all MV Series Stacker is 750 lbs.
 2. Before loading or unloading the platform, make sure the foot operated floor lock is securely locked against the floor. This requires a firm step down upon the floor lock pedal. The floor lock is released by depressing the release pedal.
 3. Always place loads on the platform as far back against the uprights as possible. Center overhanging loads on the platform. When transferring loads to the MV Series Stacker, always slide, rather than drop, heavy containers onto the raised platform.
 4. Crank in clockwise direction to raise platform. Crank in counterclockwise to direction to lower. Always remove crank handle from crank stud after cranking up or down.

SECTION 4 **OPERATION**

Carefully read and understand the instructions of this manual and all warning and instruction labels on the shoplifter. Read and understand the Operator’s Responsibility for Maintenance before using.

DANGER

- For use by trained authorized personnel only.
- Death or serious injury can result if MV Series Stacker is not kept in good working order and is not used carefully.
- Read and understand instruction manual before using.

CAUTION

- Do not use if MV Series Stacker is not working properly or any part is damaged or worn.
- Do not use on ramps and inclines.
- Do not use without floor lock pad securely locked against floor.
- Do not slide loads on or off platform without adequate bracing or blocking of MV Series Stacker.
- Do not drop loads on platform.
- Do not put hands, feet or any part of your body under platform.
- Do not move with platform raised.

CAUTION

Whenever pulling in cable, listen for a “clicking sound” of the ratchet. If the clicking sound stops, keep a firm grip on the handle, and lower the load to the ground by turning the handle counterclockwise. Repair the ratchet. There will not be a clicking sound whenever the cable is let out.

5. Always lower platform (especially when loaded) to its lowest position before moving the MV Series Stacker any distance.
6. Do not push MV Series Stacker and turn crank handle at the same time.
7. When positioning the MV Series Stacker next to a press or bench for transferring a load, always crank up to the desired height. This assures proper contact of the pinion thrust plate and friction disc clutch.
8. A guard has been placed around the ratchet and pawl for safety and to prevent manual release of the pawl. Don’t attempt to release the pawl by hand in order to lower the platform.
9. Keep hands out of the hoist unit and away from the cable sheaves at all times.
10. Keep hands out from under the platform when loading or unloading.

OPERATOR INSTRUCTIONS

OPERATOR'S RESPONSIBILITY FOR MAINTENANCE

Death or serious injury can result if MV Series Stacker is not kept in good working order. Inspection and maintenance should be performed by competent personnel who are familiar with mechanical and hydraulic procedures.

The operator should be assured that the MV Series Stacker is being properly maintained before using it. The maintenance portion of the manual includes information on lubrication and inspection points that must be performed daily, weekly and monthly.

NOTE: Certain ambient conditions may require special lubricants or shortening of interval between lubrications. Check with an oil company representative for additional information.

1. WINCH. Apply a thin coat of rust inhibiting oil or drislid to bearings, threaded portion of shaft and pawl stud. Drum must rotate freely on drum shaft.

WARNING

Do NOT lubricate friction discs or metal surfaces that the discs contact. Do not use spray oil.

2. Wipe wire rope clean with a cloth. Apply rust inhibiting oil to entire length of rope.

3. Apply No. 2 cup grease to entire length of inside flanges of uprights.

NOTE: If oil lubricant has been contaminated with atmospheric particles, wash old lubricant off with kerosene and wire brush.

4. Apply rust inhibiting oil to sheaves and platform guide wheels.

5. Apply No. 2 cup grease to wheels.

6. Apply light machine oil to floor lock.

LUBRICATION POINTS

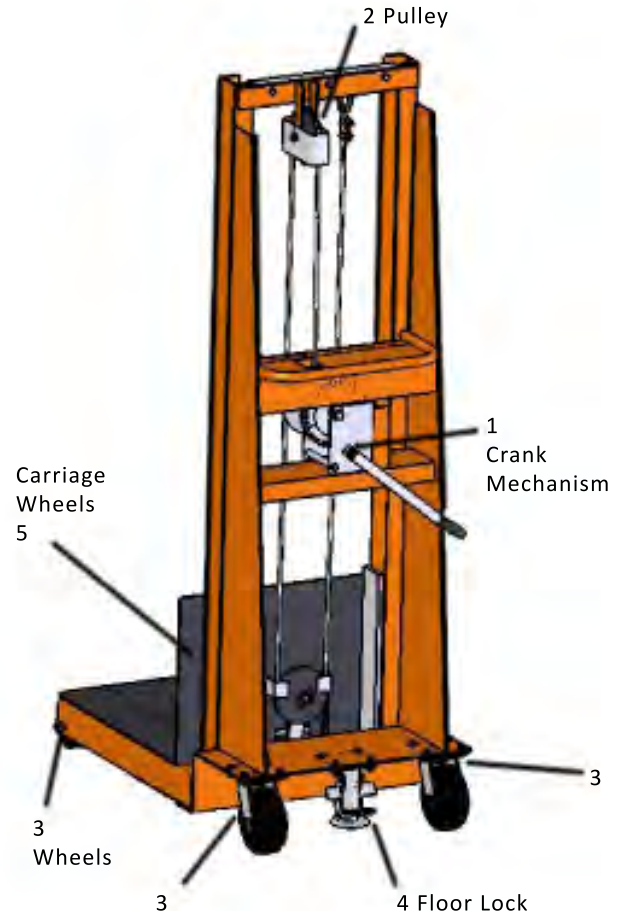

7. Clean and oil safety device shaft bearings and linkage.

CAUTION

Inspection should be performed by a competent and responsible person familiar with procedures as outlined in this manual and a wire rope handbook.

ASSEMBLY INSPECTION POINTS

1. Daily check floor lock for positive locking and defects.
2. Daily check safety device for proper operation.
3. Weekly check all nuts and bolts for tightness.
4. Weekly inspect wheels.

5. Weekly clean dirt from teeth of steel dogs.
6. Daily check uprights for abrasives, dirt and oil caked contaminants.
7. Daily keep all parts not requiring lubrication clean of lubricants. Pay particular attention to handcrank, outside of uprights and platform where personnel injury could result from slippery lubricant.
8. Daily check structural frames for damage and cracked welds.

HOIST MECHANISM INSPECTION POINTS

1. Weekly inspect wire rope sheaves
2. Weekly clean, inspect and tighten wire rope clamps and thimbles.
3. Daily check winch for damage and insufficient lubrication.
4. Weekly make certain pawl has freedom of rotation.

LOAD CENTER

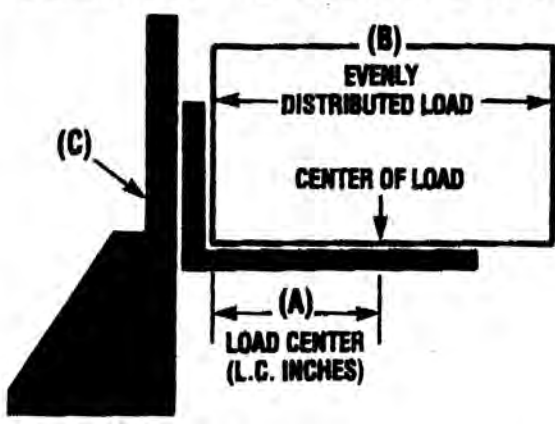

A. Load center (L.C.) is measured horizontally from back of forks or platform.

B. Center of evenly distributed load should not exceed rated load center (L.C.) capacity. Overall length of load should not be more than twice the rated load center capacity.

C. See data plate for load center capacity; measured in inches.

DO NOT EXCEED LOAD CENTER

5. Weekly check ratchet for wear and damage; be sure pawl has full face engagement.
6. Weekly tighten wire rope connection bolts at drum
7. Monthly inspect drum for freedom of rotation when shaft is stationary.
8. Monthly check alignment of shaft (bent shaft indicates cranking in reverse of the normal procedure).
9. Weekly winch support bolts should be tightened.
10. Monthly clean wire rope with compressed air using all necessary safety precautions, or with kerosene and wire brush.
11. Daily the entire wire rope length should be inspected to determine if any section has suffered severe deterioration, which will be evidenced by one or more of the following: Reduction in rope diameter, worn or a braided wires, broken wires, corroded wires. Marks of mechanical abuse such as deterioration, striations or crushing.
12. Monthly lubricate entire length of wire rope. See Lubrication Instructions.

*Replace winch cover making sure it is clean, straight and does not restrict movement of pawl in any manner.

CAUTION

The hoist rope should be replaced at least every 18 months or whenever there are four or more broken wires in one lay of the rope, or if damaged, kinked, or in a deteriorated condition.

A new kit with installation instructions is available from Presto Lifts, Inc.

SAFETY DEVICE

All MV Series Stackers are designed with maximum safety in mind. An additional feature on all platform model MV Series Stackers is the platform safety device. This device will keep the platform from falling if the hoist wire rope breaks. It consists of steel dogs mounted on both ends of a common shaft underneath the platform. A linkage system connects the shaft to a floating sheave on the platform. The sheave is kept in place by wire rope tension and is released if the wire rope goes slack or breaks, thus forcing the dogs against the uprights.

NOTE: The safety device is standard on the platform plate, MV Series Stackers only. It is not available on any of the fork model MV Series Stackers.

TESTING SAFETY DEVICE

When performing regular maintenance task, the safety device should be tested for proper operation.

1. Engage foot operated floor lock.
2. Raise platform at least 12 _ inches.
3. Place a 12 inch long 2X4 upright on one side and under the platform frame.
4. Lower platform until bottom of platform frame rests on top of 2X4..

CAUTION

Keep arms and legs out of MV Series Stacker area.

5. Continue to crank 2 complete turns to achieve a slack wire rope condition and remove crank from main shaft.
6. With a rod or 2X4 which is at least 36 inches long – stand clear of machine – sharply hit upright 2X4 at floor line away from the mast.
7. The safety dogs should rotate into the uprights and platform should not have fallen more than 2 inches. A slack wire rope condition should still exist.

Please call the Presto Parts Department with you model and serial number for pricing and availability.

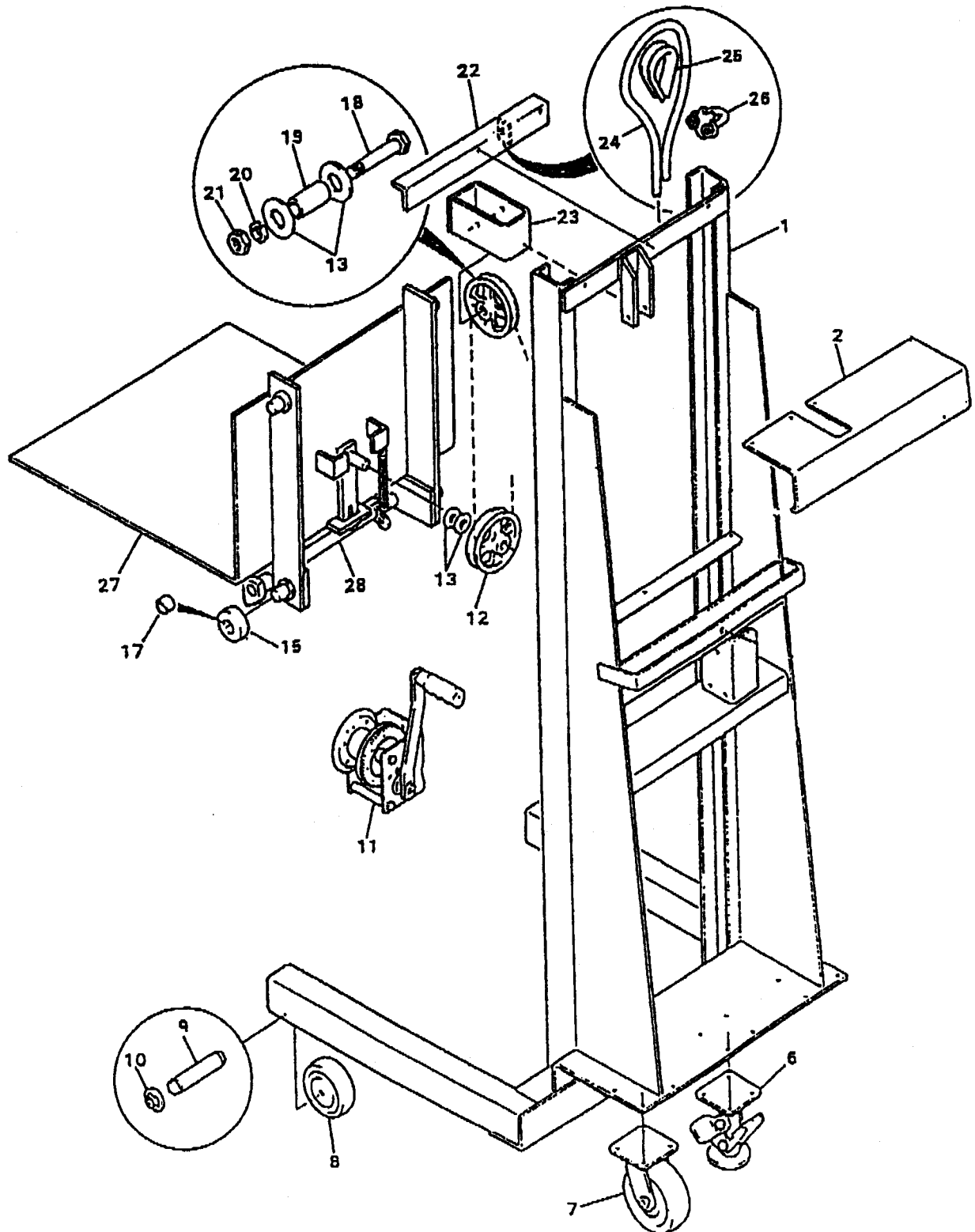

Ordering Replacement Parts

Presto Lifts has carefully chosen the components in your unit to be the best available for the purpose. Replacement parts should be identical to the original equipment. Presto Lifts will not be responsible for equipment failures resulting from the use of incorrect replacement parts or from unauthorized modifications to the unit.

Presto Lifts can supply all replacement parts for your lift. With your order, please include the model number and the serial number of the unit. You can find these numbers on the name plate. This plate is located on the angle support at the top of the cylinder.

To order replacement parts, please call the Presto Parts Department. Parts are shipped subject to the following terms:

- FOB factory
- Returns only with the approval of our Parts Department.
- Credit cards preferred (except parts covered by warranty).
- Freight collect for truck (except parts covered by warranty).
- Freight prepaid and invoice for small parcel shipments (except parts covered by warranty).

Parts replaced under warranty are on a “charge-credit” basis. We will invoice you when we ship the replacement part, then credit you when you return the worn or damaged part.

Presto Parts Department

21 Park Street
Attleboro, MA 02703

Telephone: 800-343-9322

FAX: 888-788-6496

Email: parts@PrestoLifts.com

www.PrestoLifts.com

PARTS

Standard parts may be returned with a 20% restocking fee or \$35.00 net, whichever is greater. Modified or custom-engineered parts are not returnable. Unfortunately, due to potentially concealed damage, all sales of electrical assemblies are final.

QUALITY ISSUES

Should you feel there is a quality problem, please contact the seller to ask questions and gather information on how to rectify the issue. Presto Lift Inc. reserves the right to determine potential credits, as a result of factory defects, based on its inspection of the merchandise.

GENERAL

All products shipped from our factory have passed Quality Assurance inspection and testing. The carrier of choice has signed for, and accepted the product in new working condition. The customer should inspect to ensure it is not received damaged, has no concealed damage or is not incomplete. Parts orders are determined to be complete based upon Presto Lift, Inc. inspection sheets and carrier shipping weights.

RETURN GOODS AUTHORIZATION POLICY

Presto Lifts provides the Return Goods Authorization (RGA) Policy, for specific models, as a courtesy to our distributors in the event they do not receive what they ordered. If a customer wishes to return a Presto Lifts product, please contact the Customer Service Department and request an RGA number. This request must be made on or before the fifteenth calendar day following the date of Presto Lifts' invoice for the merchandise. Not all units are returnable. Quantity orders and special designs cannot be returned under any circumstances. Presto Customer Service reserves the right for final judgment on all product returns.

The RGA number must appear on the outside of any packaging material for a return to be accepted and processed by Presto Lifts. Customers shipping returns from the Continental US, Canada, or Mexico have thirty (30) days from date of RGA issue to have the product arrive at Presto Lifts' facility. All merchandise must arrive Free on Board at Presto Lifts' facility or the shipment will be refused and returned to the sender. All credits are issued less restocking and refurbishing charges, regardless if the merchandise was damaged in transit.

Return addresses: please refer to your RMA for the address to which your product should be returned.

Presto Lift Inc.
715 Highway 77
Manila, Arkansas 72442

Telephone: 800-343-9322
Fax: 888-788-6496

Presto Lifts Limited Warranty Policy

Presto Lifts warrants all of its products against defects in the welded structural frame and, if applicable, scissor legs from faulty material and workmanship for a period of five (5) years from the date of invoice.

All other components have a limited warranty against defects in faulty material and workmanship for a two (2) year period from the date of invoice and 30 day limited warranty on labor. Please note that prior authorization from Presto Lifts is required on all warranty work.

There are no implied warranties of any kind, more specifically, there are no warranties of merchantability or fitness for any particular purpose. Presto Lifts' sole warranty shall be as set forth in this limited warranty.

Presto Lifts will elect to repair or replace a defective component without charge, if any components should become defective within the limited warranty period. Proof of purchase is required for warranty. The charge for shipping the defective component is the responsibility of the buyer and must be accompanied with an RGA number. The shipping charge to return the component to the buyer is the responsibility of Presto Lifts, Inc.

This limited warranty does not cover labor expense for removal or reinstallation of components after thirty days. This limited warranty shall not cover, among other things: damages resulting from foreign matter or water, failure to provide reasonable and necessary maintenance, and if applicable, use of product while charger is plugged into an AC outlet, or failure to follow operating instructions. The limited warranty is not valid for damage resulting from negligence, accident, unreasonable use, abuse or misuse, exceeding data plate capacities or altering the product without Presto Lifts authorization.

Presto Lifts expressly disclaims and excludes any liability for consequential, incidental, indirect or punitive damages or financial loss to people or property resulting from any breach of warranty or the operation or failure of this product.

Presto Lifts makes no representation that this product complies with local, state, or federal safety/product standards codes. Should this product fail to comply in any way with those codes, it shall not be considered a defect of materials or workmanship. Presto Lifts shall not be held liable for any damages resulting from noncompliance. It is the dealer's responsibility to exercise this limited warranty. This limited warranty is provided to the original purchaser (defined as the original end user) and is nontransferable. This constitutes the complete and final agreement involving Presto Lifts and limited warranty obligations for products.

MANY NEEDS REQUIRE MANY OPTIONS...

Presto LIFTS



LET PRESTO MEET THOSE NEEDS!

Call Presto Sales
for stock or
customized lift inquiries:
800-343-9322

Email: sales@prestolifts.com

