

Presto LIFTS™
worldwide material handling
and ergonomic solutions

AX, AXR, AXS, AXT & AT Series Scissors Lifts



Installation, Operation and Service Manual

Model # _____

Serial # _____

Date Placed in Service _____

**IMPORTANT: READ CAREFULLY
BEFORE INSTALLING OR OPERATING LIFT**

Part orders are subject to a \$50 minimum charge.

April 2007



The Presto Five Year Warranty

Presto Lifts, Inc. warrants all of its products against defects in the welded structural frame and, if applicable, scissor legs from faulty material and workmanship for a period of five years from the date of invoice. To read more about the warranty on this equipment, please turn to the back inside cover of this owner's manual.

This manual was current at the time of printing. To obtain the latest, most updated version, please contact the Customer Service Department or go to our website: www.PrestoLifts.com -- you will find a complete list of current owner's manuals to print.

C O N T E N T S

SECTION 1: Introduction	4
SECTION 2: Safety	4
SECTION 3: Installation	5
A. Inspection	5
B. Installing	5
C. Pneumatics	6
D. Testing the Lift with No Load	6
SECTION 4: Operation	6
A. Method of Operation	6
B. Operation Procedures	7
SECTION 5: Maintenance	7
A. Safety Chocks	7
B. Routine Inspection and Maintenance	8
C. Troubleshooting Maintenance	9
D. Removal and Installation of Air Stroke Actuator	9
E. Removal and Installation of Hand/Foot Control	9
SECTION 6: Turntable	9
SECTION 7: Pneumatic Positioning Lock	10
ORDERING REPLACEMENT PARTS	18
RESTOCKING POLICY	19
RETURN MATERIALS AUTHORIZATION (RMA) PROCEDURES	20
WARRANTY	21
LIST OF FIGURES:	
Figure 1. Lagging down lift	6
Figure 2. Maintenance Chocks	7
Figure 3. Pneumatic Connections	8
Figure 4. Pneumatic Connections with Lock	10
Figure 5. Pneumatic Components	12
Figure 6. Pneumatic Components with Turntable	12
Figure 7. Standard Components	14
Figure 8 Mechanical Components	16
Figure 9 Pneumatic Schematic, AX / AT	17

S E C T I O N 1

INTRODUCTION

This manual attempts to provide all of the information necessary for the safe and proper installation, operation and maintenance of Presto AX/AXR/AXS/AXT/AT Series Scissors Lifts. It is important that this manual be read by all personnel involved with the installation, maintenance or operation of the scissor lift. If the manual does not address an application, call your distributor or Presto Lifts for assistance. Additional manuals are available upon request at www.PrestoLifts.com.

The scissor lift has a nameplate that provides the load capacity rating, serial number and model identification. Please refer to these numbers when ordering parts or requesting further information.

The AX/AXR/AXS/AXT/AT Series Scissor Lifts are designed for lifting, lowering and positioning a wide variety of loads. **WHERE UNIQUE SITUATIONS ARISE, THAT ARE NOT COVERED IN THIS MANUAL, CALL YOUR DISTRIBUTOR OR PRESTO LIFTS FOR INSTRUCTIONS.**

The AX/AXR/AXS/AXT/AT Series is designed for in-plant/non-hazardous location use only.

S E C T I O N 2

SAFETY

The AX/AXR/AXS/AXT/AT Series Scissor Lifts are very powerful lifts capable of doing large amounts of work. They contain scissor legs, which are pneumatically actuated and are capable of causing serious injury or damage if adequate precautions are not taken. **DO NOT INSTALL OR OPERATE THESE LIFTS WITHOUT CAREFULLY READING THIS MANUAL.** Presto Lifts, Inc. has identified certain hazards which may occur during the installation, maintenance and use of these lifts.

The following system has been established for identification of potentially unsafe conditions or practices and is used throughout this manual.

DANGER! – Immediate hazard that will result in severe personal injury or death.

WARNING! – Hazard or unsafe practice that could result in severe personal injury or death.

CAUTION! – hazard or unsafe practice that could result in minor personal injury or property damage.

In the interest of safety, please read the entire manual carefully. You must understand the material in this manual before you install, use, or service the unit. If you have any question about any of the instructions in this manual, please contact Presto Lifts Inc. at 1-800-343-9322.

WARNING!

- Do not perform any repair work on a lift with a load on the platform or with the table in a raised position.
- All personnel must stand clear of the lift when the lift is in motion.
- Do not put hands or feet under lift table.
- Do not perform any repair or maintenance work with the lift in an open position without securing it first with proper maintenance devices.
- Do not stand, sit or climb on the lift at any time.
- Do not use the lift on soft, uneven or unstable surfaces.
- Do not exceed the load capacity rating on the data plate.
- Do not place a load on a moving lift.
- Do not exceed load capacity.
- Place a load in the center of the lift and be sure that the load is secured properly.

SECTION 3 INSTALLATION

A. INSPECTION:

Upon receipt of the AX/AXR/AXS/AXT/AT Scissor Lift, inspect the equipment completely to determine if there is any damage that occurred during shipment and that the lift is complete. **Do not** use the lift if there appears to be any damage. Check the following with the lift in the collapsed position:

1. Check for signs of damage, especially to the Airstroke Actuator™ and pneumatic components.
2. Check all connections and nuts/bolts for tightness.
3. Check base frames for flatness and for bent or damaged metal parts.

CAUTION!

Do not operate the lift before performing the installation procedures specified in section B. Severe damage to the lift may occur.

B. INSTALLING:

1. Floor Installation

- a) Make sure that the floor in the installation area is flat, stable, relatively smooth and free from dirt, obstacles or surface defects.
- b) Place the lift in the exact operating position.

CAUTION!

When moving the lift *never* attempt to pick it up by the cover. The lift should be picked up only by the base frame only. The use of a spreader strap/sling is suggested. If the lift has lifting eyebolts, attach a chain spreader and raise the lift from a center position. Be sure that the eye bolts are secured in place with locking nuts prior to lifting.

- c) Make sure that the complete base of the lift is in contact with the floor. In order to provide complete contact with the floor, the base may be shimmed or grouted.

CAUTION!

Do not spot shim. The complete base must be in contact with the floor or shims.

- d) The lift frame must be anchored to the floor using (4) 3/4" diameter bolts, washers and nuts.
- e) Locate and lag down hand control stand or foot control so as to provide easy access. Do not obstruct the operator's work area. Make pneumatic connections according to the information contained in Section 3C.

CAUTION!

Not lagging the lift base will result in structural damage to the lift.

2. Pit Mounted Installation

- a) Build pit to standard pit dimension as outlined in figure 2, paying careful attention to raceway, clearance and height requirements.
- b) The remaining steps are the same as required for floor installation. See section 3B.

WARNING!

Do not install lifts in pits unless they have an approved bevel edge top and fully exhausting pneumatic circuit.

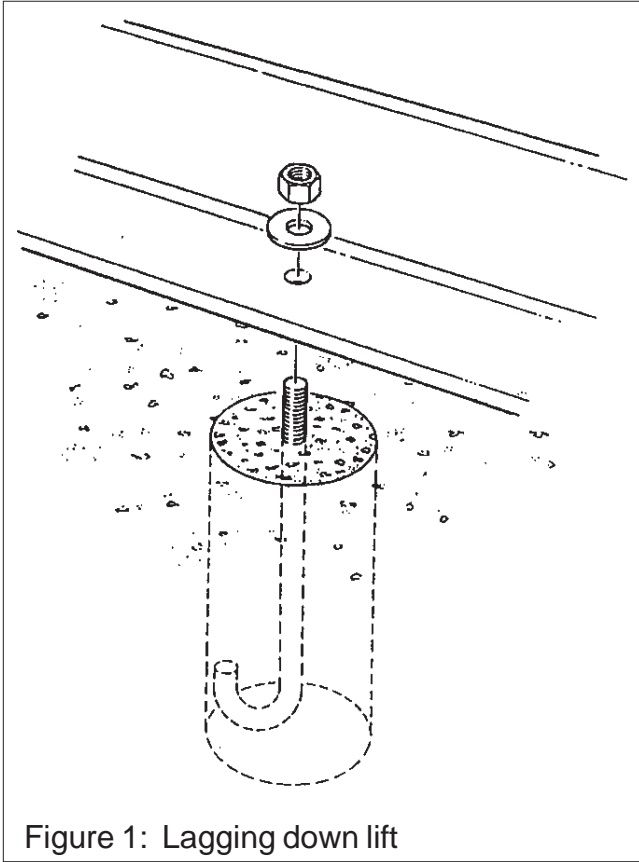

Figure 1: Lagging down lift

C. PNEUMATICS:

AX/AXR/AXS/AT Scissor Lifts are designed for normal factory environments. Consult the distributor for unusual applications. If your lift is equipped with a turntable positioning lock, refer to Section 6B.

CAUTION!

All pneumatic connections should be performed by qualified authorized service personnel.

1. The lift requires a minimum of 80 PSI, 15 CFM, and clean dry air to function correctly.
2. Be certain that supply line is turned off and residual air has been purged from the line.
3. The lift is shipped with the control line attached to the control valve (B) and detached from the lift base. Route the control line safely to the base and make the connection (C).
4. Connect the supply line to the open port of the control valve (A).
5. Open the air supply and check the entire circuit for leaks. Secure as needed. See Fig. 3.

WARNING!

The lift is equipped with a tamperproof pressure regulator. The regulator has been factory preset and no attempt should be made to alter the setting. Resetting of the regulator or replacement with a component not supplied by Presto Lifts will void warranty and could result in serious bodily injury.

D. TESTING THE LIFT WITH NO LOAD:

1. Before testing the lift, clear the area of any loose material. Be sure the lift has no obstruction above it or on any side. Using the controls provided, briefly operate the lift (5-10 seconds). If the lift begins to rise and functions properly, continue to the full upright position.

CAUTION!

If the lift does not rise immediately, or there is any operational problem, stop it immediately. Refer to the troubleshooting section and correct the problem before continuing.

2. After raising the lift completely, lower the lift completely. It should lower slowly and smoothly. If satisfied with the lift's operation, raise and lower the lift and stop at different levels in order to familiarize yourself with the lift's operation.

SECTION 4

OPERATION

A. METHOD OF OPERATION:

The control valve controls the flow of air to the Air Stroke Actuator™. As the actuator is pressurized, the scissor legs are forced apart causing the tabletop to rise. As air is released from the bag, the legs collapse and the top is lowered. A factory preset flow control ensures a smooth descent at a controlled speed.

CAUTION!

Do not maintain the control valve in the open position if the lift does not move or it has reached its up or down limits. Damage to the pneumatic system may result.

B. OPERATION PROCEDURES:

In order to operate the lift, follow these operating procedures:

1. Read and understand all the instructions before operating. If the lift has modifications or accessories, read and understand their functions.
2. Load the lift correctly. Refer to the attached nameplate for load capacity information.
 - a) Load the lift only in the fully lowered position.
 - b) *Do not* load the lift while it is running.
 - c) *Do not* exceed the maximum rated load (note that load capacity is reduced due to side or end loading).
 - d) Place load in the center of table.
 - e) If the load is unstable or may become unstable, fasten it into position.
3. Operate the lift.
 - a) To raise the lift, activate the hand control valve to the “up” position. Hold the valve open until the lift reaches the desired position or the lift reaches its full extension. The valve is spring-loaded and will return to center (closed) when the lever is released.
 - b) To lower the lift, activate the hand control valve to the down position. Hold the valve open until the lift descends to the desired height or the lift reaches its fully lowered position. Move the valve briefly to the up position to stop downward movement.
4. Wait until the lift has come to a complete stop before unloading the lift.
5. Stand clear of the lift when operating in order to avoid injury.

WARNING!

- a) **Load the lift only in the collapsed position.**
- b) ***Do not* stand, sit or climb onto the lift.**
- c) **If the lift fails to move or exhibits strange movement or sound, stop immediately. *Do not* operate the lift until it has been checked and repaired.**
- d) ***Do not* load or unload a moving lift.**
- e) **Obey all warning labels.**

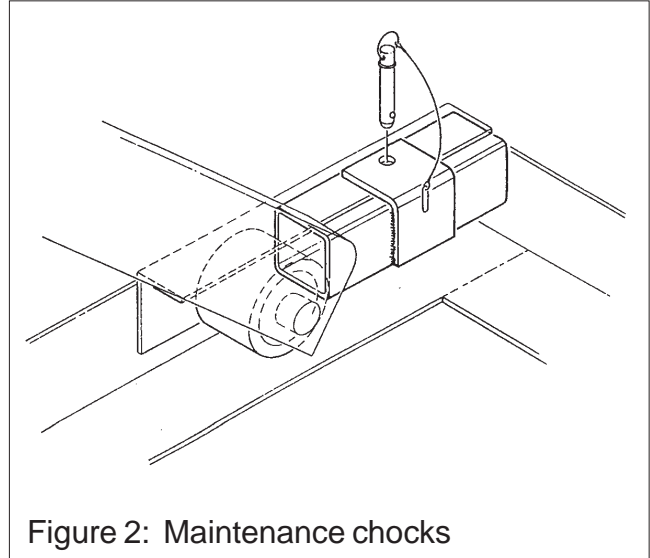

Figure 2: Maintenance chocks

SECTION 5

MAINTENANCE

Generally, the AX/AXR/AXS/AXT/AT Series of pneumatic scissor lifts will require little maintenance. However, routine maintenance and inspection will minimize cost of repairs and hazardous conditions.

WARNING!

Never go under or service lift with a load on the table or with the scissor mechanism loaded. If possible, service the lift in a down position.

WARNING!

If the pneumatic system requires repairs, shut off and lock out the air supply. Purge the system of any pressure before beginning any repairs.

A. SAFETY CHOCKS:

The AX/AXR/AXS/AXT/AT Series Lifts are designed to be maintained and serviced in a raised position. Maintenance chocks are provided for safely locking the lift in a raised position. Refer to Figure 2.

1. Chock Installation

- a) Completely remove any load from the lift platform.
- b) Raise the lift to its full height.
- c) Slip the maintenance chock (A) in place and insert the locking pin (B). Be sure to use both chocks.

- d) Lower the lift until the rollers come in contact with the maintenance chock.
- e) Check that the maintenance chocks are securely in place.
- f) Release all air pressure from the lift. The chocks are now supporting the lift.

2. Chock Removal

- a) Raise the lift to its full height.
- b) Remove the locking pin (B) and the maintenance chock (A).
- c) Lower the lift.

B. ROUTINE INSPECTION AND MAINTENANCE:

All routine inspection maintenance should be performed on a weekly basis.

- 1. With the lift unloaded and its fully raised position, check the pneumatic system for leaks.
 - a) Check all fittings, lines and components for escaping air.
 - b) In addition to listening for an audible hissing, perform a soap bubble test.
 - c) If a leak exists, repair immediately.

WARNING!

Safety Chocks and/or safety pins must be installed on the lift while maintenance is being performed on the lift if it is in a

partially raised position. Follow chocking procedures in Section 5B. These chocks and/or pins are provided and are attached to the lift. Contact Presto Lifts, Inc. for the recommended parts, if yellow safety chocks are not available.

- 1. Inspect the following:
 - a. Check the reservoir oil level and add correct oil according to Figure 10, if necessary.
 - b. Check the rollers for sign of wear. Replace if damaged.
 - c. Check snap ring and shield on rollers. Replace if damaged.
 - d. Check hydraulic lines for damage or leaking. Replace if damaged.
 - e. Check for oil spots on the floor. Trace the leak to the proper fitting and tighten or replace.
 - f. Check wiring for damage. Replace immediately if any signs of wear are evident.
 - g. Bearings on all lifts are permanently lubricated and require no servicing. Do not oil these bearings.
- 2. Check Air Stroke Actuator™ for any signs of wear, chafing, nicks, splits, etc. Replace as specified in Section 5 (D).
- 3. Check rollers for signs of wear. Replace if damaged. Clear roller track of any debris. Refer to Figure 6.
- 4. Check roller snap ring and shield. Replace if damaged. Refer to Figure 6.

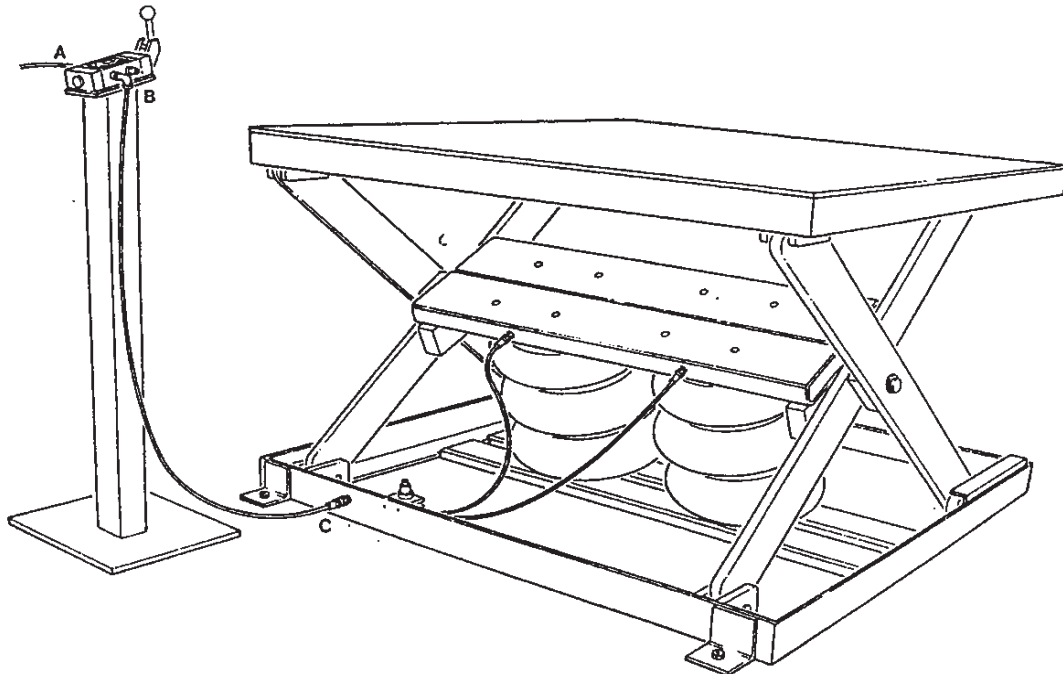

Figure 3: Pneumatic connections

5. Tighten all visible nuts and bolts.
6. Bearings on all lifts are permanently lubricated and *do not* require servicing.

C. TROUBLESHOOTING MAINTENANCE:

All servicing should be done by qualified personnel who have read and understand all of the information provided in the Operating, Installation and Maintenance sections of this manual.

LIFT MOVING SLOWLY OR NOT AT ALL

1. Check for obstructions.
2. Check for incoming air supply.
3. Check circuit for air leaks, loose connection, damaged hose, etc. Listen for air escaping.
4. Is lift overloaded? Check capacity.
5. Check control valve and regulator for sticking or jamming, repair or replace.

D. REMOVAL AND INSTALLATION OF AIR STROKE ACTUATOR™:

1. Chock the lift as specified and be sure air supply is locked out.
2. Remove the S.S braided hose (20) and brass nipple (19).
3. Remove the four 3/8-16 nuts (25) with a 9/16 deep socket. The Actuator will collapse as the last nut is removed.
4. Remove the four 3/8-16 hex head bolts (22) and washers (21). The Actuator will become free of the lift and may be removed.
5. Remove the four 3/8-16 (26) hex head bolts and lock washers (23) holding the plate (28) to the Actuator.
6. Unscrew the elbow(6).
7. Finally remove the four studs (24) from the Actuator end plates.
8. Installation is the reverse of removal. Be sure to use a Teflon sealant on all pneumatic connections. Pump must be replaced.

E. REMOVAL AND INSTALLATION OF HAND/FOOT CONTROL:

1. Chock the lift as specified and be sure air supply is locked out.
2. Disconnect hose (8) and supply line.
3. Remove [2] plugs (5), [1] muffler (4), elbow (6).

4. Remove (2) securing nuts/bolts and remove valve from stand if a hand valve.
5. Installation is the reverse of removal. Be sure to use Teflon sealant on pneumatic connections.

SECTION 6

TURNTABLE

If your lift is equipped with a rotating turntable, the following operational/ maintenance procedures apply.

A. INSPECTION:

As with the basic scissor lift, inspect the unit to be sure no damage has occurred in shipment and that the unit is complete.

1. Rotate the turntable by hand to be sure the table rotates freely without binding or unusual sounds.
2. Inspect for loose/ damaged connections and nuts/bolts.

SECTION 7

PNEUMATIC POSITIONING LOCK

B. INSTALLATION (IF EQUIPPED) OF PNEUMATIC POSITIONING LOCK:

The initial pneumatic connections differ from a standard lift and are specified below. All other installation, safety and use instructions should be observed. Refer to schematic Fig. 8 and Fig. 9.

1. Connect incoming air supply to inlet (A).
2. Connect supply line (B).
3. Connect control line (C) lifting.
4. Connect control line (D) lock.

Positioning Lock:

The lock is designed for holding the turntable in place; it is not designed to stop or brake a rotating load.

1. Manually rotate the turntable to the desired position.
2. With the turntable at rest, activate the lock control valve to the "on" position. This will lock the table in place.
3. Moving the control valve to "off" will release the lock and allow the turntable to rotate.

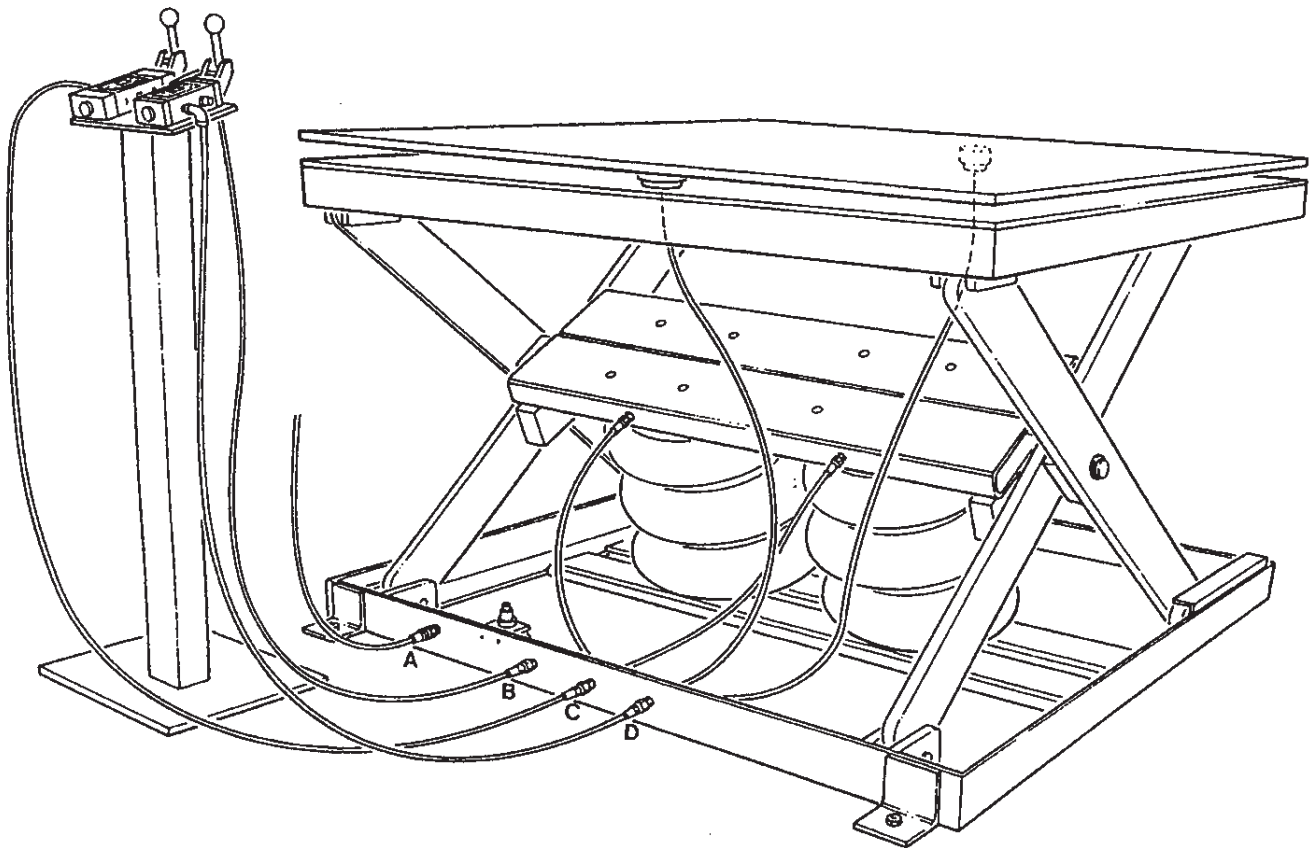

Figure 4: Pneumatic connections with lock

Pneumatic Components Replacement List					
Refer to Figure 5					
Location	Description	P/N	Qty Per Model		
			AX10	AX20	AX40
1	Pneumatic Valve	1016-075	1	1	1
2	Nameplate	1016-149	1	1	1
3	Screw	N0453	2	2	2
4	Muffler	1016-085	2	2	2
5	Plug-Oil Tank	B205	2	2	2
6	Elbow, Street	E271	3	3	4
7	Fitting	A4125	2	2	2
8	Hose	A501	1	1	1
9	Elbow	A153	1	1	1
10	Nipple, Brass	1016-080-01	1	1	1
11	Regulator	1016-073	1	1	1
12	Screw	N0454	2	2	2
13	Nut, Machine	N0019	2	2	2
14, 17	Nipple, Brass	1016-080-01	1	1	1
15	Reducer	A274-01	2	2	3
16	Quick Exhaust	1016-074	1	1	1
18	Tee Female	H103J	-	-	1
19	3" Brass Nipple	1016-080-02	-	1	2
20	SS Hose Assy.	1016-079	1	1	2
23	Washer, Lock	FW08A	8	8	16
24	Screw	N0546	4	4	8
25	Nut, Self Lock	1016-076	4	4	8
26	Screw 3/8" - 16x	N0666	8	8	16
27	Airstroke Actuator	1016-014-01	-	1	2
27	Airstroke Actuator	1016-014-02	1	-	-
28	Sub Plate Air	1016-027	1	1	2

Turntable Positioning Lock Components Replacement List
Refer to Figure 6

Location	Description	P/N	AXR10	AXR20	ARX40
1	Pneumatic Valve	1016-075	1	1	1
2	Nameplate	1016-149	1	1	1
3	Screw	N0453	2	2	2
4	Muffler	1016-085	2	2	2
5	Elbow, Street	E271	3	3	4
6	Fitting	A4125	2	2	2
7	Hose	A274-01	1	1	1
8	Plug	B205	2	2	2
10	Hose	A274-01	1	1	1
11	Regulator	1016-073	1	1	1
12	Screw	N0454	2	2	2
13	Nut, Machine	N0019	2	2	2
14	Bulkhead Fitting	1016-092	2	2	2
15	Bulkhead Fitting	1016-092	4	4	4
16	Bulkhead Fitting	1016-092	2	2	2
17	Brass Nipple 3/8"	1016-080-05	1	1	1
18	Reducer	A274-01	2	2	3
19	Quick Exhaust	1016-140	1	1	1
20	Female Fitting 3/8"	A150	1	1	2
21	Tee Male	H103BB	1	1	1
22	Tubing	1016-113	2	2	2
23	Elbow, 90 degree	1016-094	2	2	2
24	Nut, 5/8"	N0180	2	2	2
25	Washer, Lock	N0300	2	2	2
26	Air Positioner	1016-014-03	2	2	2
27	Pad Positioning	1016-096	2	2	2
28	Screw	N0816	2	2	2
29	SS Hose Assembly	1016-079	1	1	1
30	Valve, Hand 2 Pts.	1016-090	1	1	1
31	Nameplate	1016-149	1	1	1
32	Brass Nipple 1/4"	H103BB	2	2	2
33	Female Tee 1/4"	H103J	1	1	1
35	EI-Female	A153	1	1	1
36	Brass Nipple	1016-080-01	2	2	2

Figure 7: Standard components

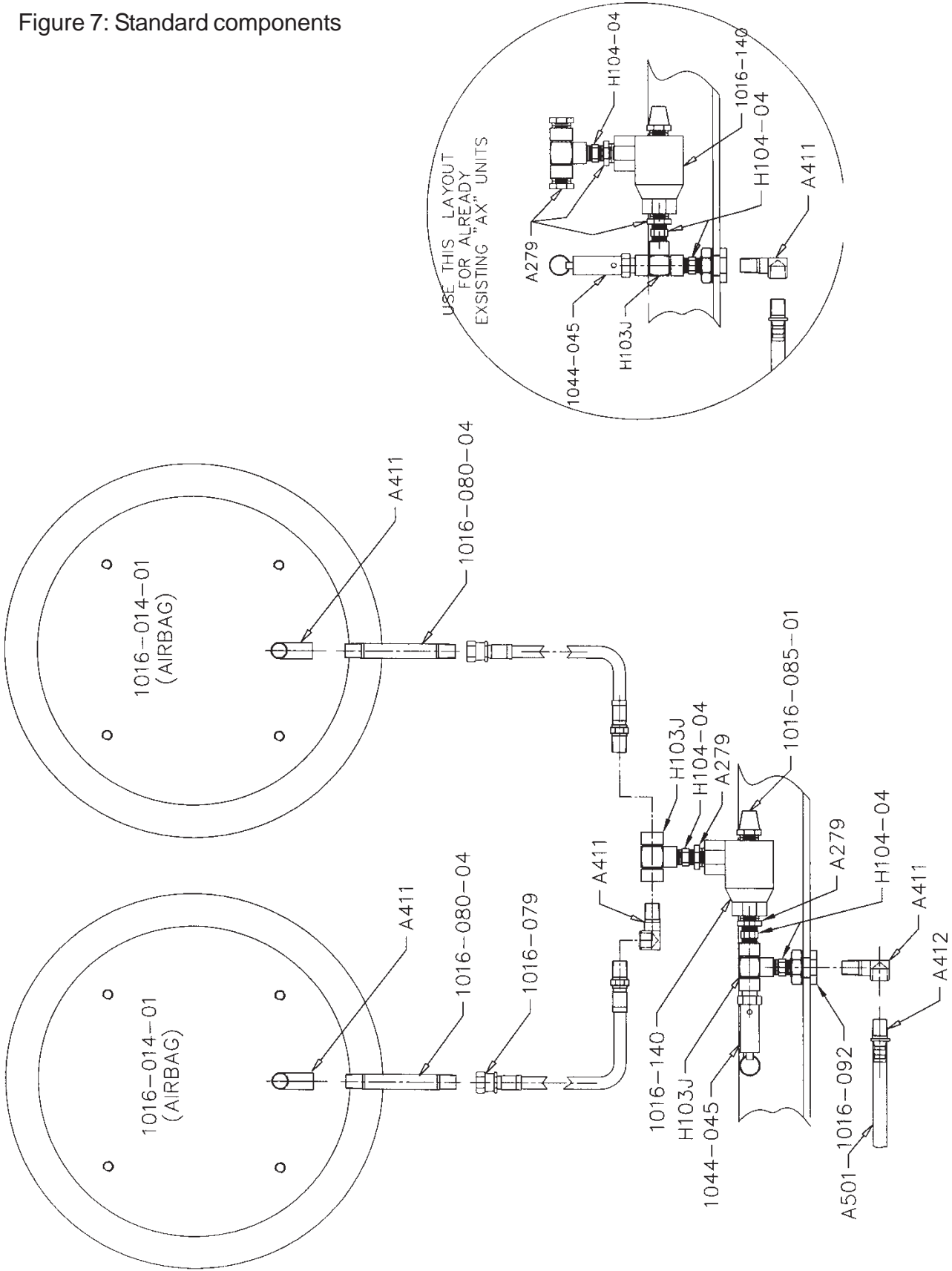

Turntable Positioning Lock Components Replacement List

Refer to Figure 7

Location	Description	Quantity per Model Number			
		P/N	AXR10	AXR20	ARX40
1	Pneumatic Valve	1016-075	1	1	1
2	Nameplate	1016-149	1	1	1
3	Screw	N0453	2	2	2
4	Muffler	1016-085	3	3	3
5	Elbow, Street	E271	3	3	3
6	Fitting	A412S	2	2	2
7	Hose	A274-01	1	1	1
8	Plug	B205	2	2	2
10	Hose	A274-01	2	2	1
11	Regulator	1016-073	1	1	1
12	Screw	N0454	2	2	2
13	Nut, Machine	N0019	2	2	2
14	Bulkhead Fitting	1016-092	2	2	2
15	Bulkhead Fitting	1016-092	4	4	4
16	Bulkhead Fitting	1016-092	2	2	2
17	Brass Nipple 3/8"	1016-080-05	1	1	1
18	Reducer	A274-01	2	2	3
19	Quick Exhaust	1016-140	1	1	1
20	Female Fitting 3/8"	A150	1	1	2
21	Tee Male	H103BB	1	1	1
22	Tubing	1016-113	2	2	2
23	Elbow, 90 degree	1016-094	2	2	2
24	Nut, 5/8"	N0180	2	2	2
25	Washer, Lock	N0300	2	2	2
26	Air Positioner	1016-014-03	2	2	2
27	Pad Positioning	1016-096	2	2	2
28	Screw	N0816	2	2	2
29	SS Hose Assembly	1016-079	1	1	1
30	Valve, Hand 2 Pts.	1016-090	1	1	1
31	Nameplate	1016-149	1	1	1
32	Brass Nipple 1/4"	H103BB	2	2	2
33	Female Tee 1/4"	H103J	1	1	1
35	El-Female	A153	1	1	1
36	Brass Nipple	1016-080-01	2	2	2

Mechanical Components Replacement List
Refer to Figure 8

Location	Description	P/N	AXR10	AXR20	ARX40
1	Pin Retain Assembly	1016-013	4	4	4
2	Screw 1/4"	N0780	4	4	4
3	Washer, Lock	N0240	4	4	4
4	Ring, External	PSL28D	4	4	4
5	Spacer	1016-082	2	2	2
6	Retaining Ring	PSL28I	2	2	2
7	Roller	1016-008	4	4	4
8	Washer, 1" ID	N0332	4	4	4
9	Rings, Lock	PSL37A	1	1	1
10	Bearing, Radial	1015-053	1	1	1
11	Bronz, Center	1015-065	1	1	1
12	Screw, Shoulder	N0999	1	1	1

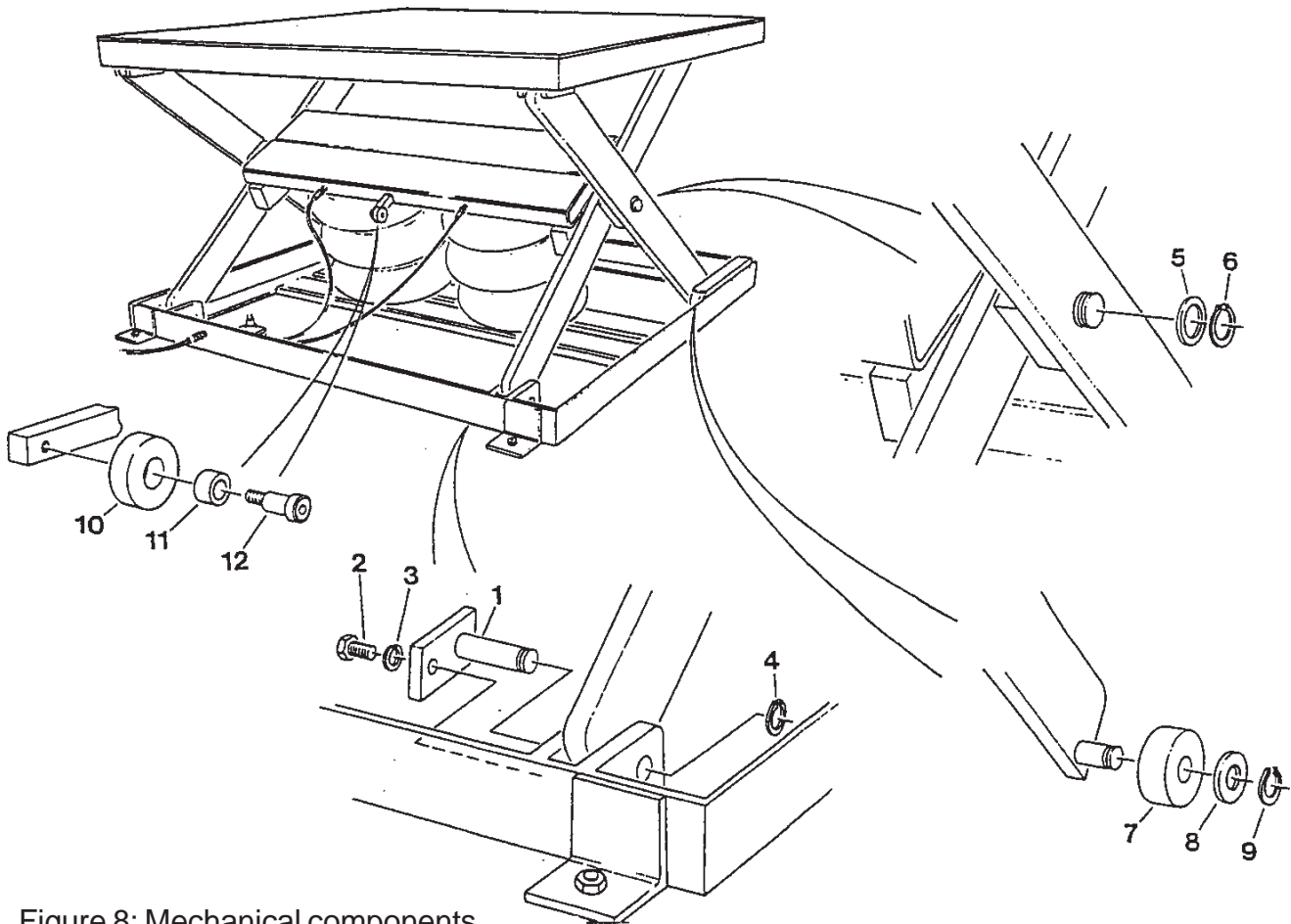
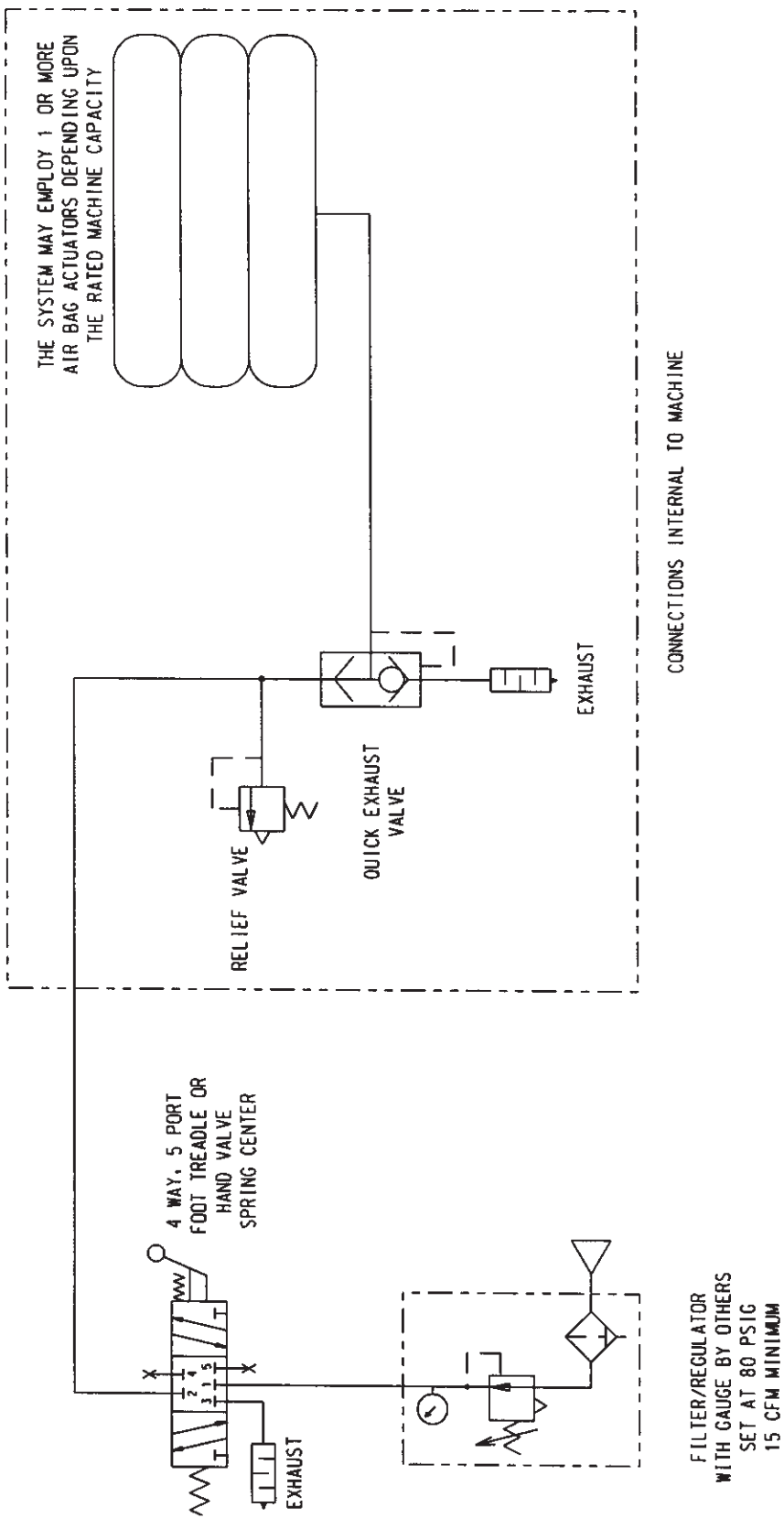

Figure 8: Mechanical components

Figure 9: Pneumatic schematic AX / AT



Ordering Replacement Parts

Presto Lifts has carefully chosen the components in your unit to be the best available for the purpose. Replacement parts should be identical to the original equipment. Presto Lifts will not be responsible for equipment failures resulting from the use of incorrect replacement parts or from unauthorized modifications to the unit.

Presto Lifts can supply all replacement parts for your lift. With your order, please include the model number and the serial number of the unit. You can find these numbers on the name plate. This plate is located within the scissors mechanism.

To order replacement parts, please call the Presto Parts Department. Parts are shipped subject to the following terms:

- FOB factory
- Returns only with the approval of our parts department.
- Credit cards preferred (except parts covered by warranty).
- Freight collect for truck (except parts covered by warranty).
- Freight – prepaid and invoice for small parcel shipments (except parts covered by warranty).

Parts replaced under warranty are on a “charge-credit” basis. We will invoice you when we ship the replacement part, then credit you when you return the worn or damaged part.

Presto Parts Department

21 Park Street
Attleboro, MA 02703

Telephone: 800-343-9322

FAX: 888-788-6496

Email: service@PrestoLifts.com

www.PrestoLifts.com

RESTOCKING POLICY

Presto Lift, Inc.'s goal is for you to be satisfied with your order. Merchandise may be returned, but returns will be subject to a restocking fee to cover the costs Presto Lift, Inc. incurs which include but are not limited to handling, storage of the units, etc. Presto Lift, Inc. will issue refurbishing costs where end-user wear is apparent. We would prefer to not charge for these costs but find it necessary any apologize for any inconvenience. Please review the RETURN MATERIALS AUTHORIZATION (RMA) PROCEDURES.

LIFTS

Lifts may be returned with a restocking fee according to the following schedule:

- Standard unit or standard unit with stock options:

Five or less	20%
With re-order	15%
Six (6) or more of the same model	30%
With re-order	20%
- Custom engineered/modified lifts: No Returns

PARTS

Standard parts may be returned with a 20% restocking fee or \$35.00 net, whichever is greater. Modified or custom-engineered parts are not returnable. Unfortunately, due to potentially concealed damage, all sales of electrical assemblies are final.

QUALITY ISSUES

Should you feel there is a quality problem, please contact the seller to ask questions and gather information on how to rectify the issue. Presto Lift Inc. reserves the right to determine potential credits, as a result of factory defects, based on its inspection of the merchandise.

GENERAL

All products shipped from our factory have passed Quality Assurance inspection and testing. The carrier of choice has signed for, and accepted the product in new working condition. The customer should inspect to ensure it is not received damaged, has no concealed damage or is not incomplete. Parts orders are determined to be complete based upon Presto Lift, Inc. inspection sheets and carrier shipping weights.

RETURN MATERIALS AUTHORIZATION (RMA) PROCEDURES

Although Presto Lift, Inc. is not legally obligated to issue a credit for any merchandise, the RETURN MATERIALS AUTHORIZATION (RMA) PROCEDURE is provided as a courtesy to our customers in the event they do not receive what they wanted.

If a customer wishes to return a Presto Lift, Inc. product, the first step in the process is to request an RMA number from Presto Lift, Inc.'s Customer Service Department. This request must be made on or before the thirtieth (30th) calendar day following the date of Presto Lift, Inc.'s invoice for the merchandise being returned.

The RMA number must appear on the outside of any packaging material for a return to be accepted and processed by Presto Lift, Inc. Customers shipping returns back to Presto Lift, Inc. from the Continental US, Canada and Mexico have fourteen (14) days from the effective date of the RMA to have the merchandise arrive freight prepaid at Presto Lift, Inc. Returns from locations other than the Continental US, Canada and Mexico must be shipped within the fourteen (14) day period to arrive Free On Board (FOB) at Presto Lift Inc as soon as practical. If a customer believes Presto Lift, Inc.'s merchandise is defective, freight will be reimbursed to the original "Bill To" on the invoice if Presto Lift Inc. finds that the merchandise is defective.

Please remember that merchandise with RMA's coming back to Presto Lift Inc. from the Continental US, Canada and Mexico will not be accepted by Presto Lift Inc. if the returned goods do not arrive freight prepaid at Presto Lift Inc. within the fourteen (14) day effective period.

All credits issued are less restocking fees as applicable, plus any assessed outbound/inbound in-transit damages.

Return addresses: please refer to your RMA for the address to which your product should be returned.

Presto Lift Inc.
715 Highway 77
Manila, AR 72442

Telephone: 800-343-9322
Fax: 888-788-6496

Presto Lifts Limited Warranty Policy

Presto Lifts warrants all of its products against defects in the welded structural frame and, if applicable, scissor legs from faulty material and workmanship for a period of five (5) years from the date of invoice.

A lifetime limited warranty is provided for the Airstroke Actuator™ in all pneumatic lifts against any defect due to faulty material or workmanship.

All batteries are covered under a separate limited warranty from the battery manufacturer for a period of one year from the date of invoice.

All other components have a limited warranty against defects in faulty material and workmanship for a two (2) year period from the date of invoice and 30 day limited warranty on labor. Please note that prior authorization from Presto Lifts is required on all warranty work.

There are no implied warranties of any kind, more specifically, there are no warranties of merchantability or fitness for any particular purpose. Presto Lifts' sole warranty shall be as set forth in this limited warranty.

Presto Lifts will elect to repair or replace a defective component without charge, if any components should become defective within the limited warranty period. Proof of purchase is required for warranty. The charge for shipping the defective component is the responsibility of the buyer and must be accompanied with an RGA number. The shipping charge to return the component to the buyer is the responsibility of Presto Lifts, Inc.

This limited warranty does not cover labor expense for removal or reinstallation of components after thirty days. This limited warranty shall not cover, among other things: damages resulting from foreign matter or water, failure to provide reasonable and necessary maintenance, and if applicable, use of product while charger is plugged into an AC outlet, or failure to follow operating instructions. The limited warranty is not valid for damage resulting from negligence, accident, unreasonable use, abuse or misuse, exceeding data plate capacities or altering the product without Presto Lifts authorization.

Presto Lifts expressly disclaims and excludes any liability for consequential, incidental, indirect or punitive damages or financial loss to people or property resulting from any breach of warranty or the operation or failure of this product.

Presto Lifts makes no representation that this product complies with local, state, or federal safety/product standards codes. Should this product fail to comply in any way with those codes, it shall not be considered a defect of materials or workmanship. Presto Lifts shall not be held liable for any damages resulting from noncompliance. It is the dealer's responsibility to exercise this limited warranty. This limited warranty is provided to the original purchaser (defined as the original end user) and is nontransferable. This constitutes the complete and final agreement involving Presto Lifts and limited warranty obligations for products.

Go Presto LIFTS™

MANY NEEDS REQUIRE
MANY OPTIONS...



Lift Table



Lift Stik



Post Tables



Double Lift Table



Counterweight Stacker



Portable Lift



P3

LET PRESTO MEET THOSE NEEDS!

Call Presto Sales
for stock or customized lift inquiries at

800-343-9322

Email: sales@prestolifts.com



Pneumatic Lift/Tilt



Pallet Jack



Stacker



Portable Tilter



Floor Level Lift