

XF, WXF & XP, WXP Series

Foot Pump Operated Scissor Lifts

Installation, Operation and Service Manual

Model Number _____

Serial # _____

Date placed in service _____

**IMPORTANT: READ CAREFULLY
BEFORE INSTALLING OR OPERATING LIFT**

Part orders are subject to a \$50 minimum charge.



This manual was current at the time of printing. To obtain the latest, most updated version, please contact Presto Lifts Customer Service Department or go to our website: www.PrestoLifts.com -- you will find a complete list of current owner's manuals to print.

CONTENTS

SECTION 1: Introduction	4
SECTION 2: Safety	4
SECTION 3: Installation	5
A. Uncrating and Inspection	5
B. Installing	5
C. Hydraulics	6
D. Testing Lift No Load	6
SECTION 4: Operation	6
A. Method Of Operation	6
B. Operation Procedures	6
SECTION 5: Maintenance	7
A. Routine Maintenance	7
B. Routine Checks	7
SECTION 6: Service	8
A. Replacing Cylinder Seals	8
B. Replacing Leg Rollers	8
SECTION 7: Troubleshooting	9
A. Standard Replacement Parts	10
 LIST OF FIGURES:	
Fig. 1 Maintenance Chock	8
Fig. 2 Foot Pump Assembly	11
Fig. 3 Handle/Caster Plate Assembly	12
Fig. 4 Anchor Bolt Details	12
Fig. 5 Hydraulic Schematic	12
Fig. 6 Maintenance Position	13
Fig. 7 Cylinder Assembly	14
Fig. 8 Hydraulic System Under Caster Plate (Prior to 10/6/04)	15
Fig. 9 Hydraulic System Under Caster Plate (After 10/7/04)	16
Table 1 Hydraulic Oil Specifications	17
Table 2 Standard Specifications and Derating Chart	17
 RESTOCKING POLICY	18
RETURN MATERIAL AUTHORIZATION (RMA) PROCEDURES	19
ORDERING REPLACEMENT PARTS	20
WARRANTY	22

SECTION 1

INTRODUCTION

The Presto XF & XP Series Lightweight Scissor Lifts are designed for use in most manufacturing and assembly environments. They provide lifting, lowering, positioning and transporting of a wide variety of materials and components. They are available in portable and stationary models with foot pump operation.

The Scissor lift has a nameplate, which provides the load rating, serial number and model identification. Please refer to these numbers when ordering parts or requesting further information.

**WHERE UNIQUE SITUATIONS OR APPLICATIONS ARISE,
WHICH ARE NOT COVERED IN THIS MANUAL,
CALL PRESTO LIFTS SERVICE DEPARTMENT FOR FURTHER ASSISTANCE.**

SECTION 2

SAFETY

The safety of all persons installing, using, servicing, or working near the unit is of paramount concern to Presto Lifts. The lift is a powerful machine with moving parts, and is **capable of causing personal injury if proper precautions are not taken**. Therefore, throughout this manual, Presto Lifts has identified certain hazards, which may occur in the use of the unit, and provided appropriate **instructions** or precautions that should be taken to avoid these hazards. In some cases, Presto Lifts' has also pointed out the **consequences** that may occur if Presto Lifts' instructions or precautions are not followed. Presto Lifts uses the following nationally recognized system for identifying the severity of the hazards associated with its products:

DANGER – Immediate hazard that will result in severe personal injury or death.

WARNING – Hazard or unsafe practice, that could result in severe personal injury or death.

CAUTION – hazard or unsafe practice, that could result in minor personal injury or property damage.

In the interest of safety, please read the entire manual carefully. You must understand the material in this manual before you install, use, or service the unit. If you have any question about any of the instructions in this manual, please contact Presto Lifts Inc. at 1-800-343-9322.

The XF and XP Series Scissor Lifts have lift capacity of 1000 lbs and 1500 lbs. The lift is raised and lowered by scissor legs, which are powered by a foot operated hydraulic pump and cylinder assembly. Therefore, great care must be exercised during the installation, operation and maintenance of the lift. **DO NOT INSTALL OR OPERATE THIS LIFT WITHOUT FIRST READING AND UNDERSTANDING THIS MANUAL.**

In order to provide for the safe operation of the scissor lift, Presto Lifts has identified certain hazards, which may occur during the installation, maintenance and use of these lifts. For safety reasons, the XF & XP Series lifts with standard tabletop are designed to be serviced in a collapsed position. Lifts with oversized tabletops require special handling. (See Section 5, Maintenance)

WARNING!

Do not perform any repair work on lifts with a load on the platform or with the table in a raised position. All personnel must stand clear of the lift when table is in motion.

Do not put hands or feet under lift table.
Do not work under table without securing lift.
Do not stand, sit, or climb on the lift.
Do not use the lift on soft, uneven or unstable surfaces.
Do not exceed load capacity.
Do not place load on moving lift.
Place loads in center of table and secure loads properly.
Do not raise or lower lift while maneuvering.
Do not lower foot pump operated lifts quickly or with jerky motions.

SECTION 3 INSTALLATION

A. UNCRATING AND INSPECTION

The XF & XP Scissor Lifts have been specially packaged to prevent damage in shipment. Upon receipt of the lift, uncrate following the special instructions attached to the lift's outer sleeve. With the lift in a collapsed position, carefully raise the top to its over center position (see figure 6), secure in place, then check the following:

CAUTION!

Lifts with oversized tabletops must not be overextended since doing so may disassociate the cylinder base from its socket. (See Section 5, Maintenance)

1. Check for signs of damage especially to the cylinder and hydraulic hoses.
2. Check connections for leaks and tightness.
3. Inspect for bent or damaged metal parts.

CAUTION!

When moving the lift, do not attempt to pick it up by the tabletop. The lift should be picked up by the base only.

B. INSTALLING

1. HANDLE ASSEMBLY

- a. Portable lifts have the push handles removed for ease of shipping. Handles should be inserted in the holders until they bottom out, then tighten the set screws on each holder with an allen wrench (see figure 3)
- b. Stationary lifts have a stability handle. The stability handle is installed using the bolts, nuts and lock washers provided.
- c. Foot operated lifts have a control knob, rod assembly and foot pedal which must be attached. To attach the control knob and rod, remove the knob and insert the rod through the guide on the handle. Place the adapter end of the control rod over the shaft. Lock in place using the Allen set screws provided. Now replace the knob on the rod and secure with the Allen screws provided (see figure 3).

The control rod guide must line up vertically with the flow control shaft. To attach the pedal, insert pedal shaft in pump holder and bolt in place with bolts provided.

2. FLOOR INSTALLATION

- a. The floor in the installation area should be flat, stable and free from debris and surface defects.
- b. Place lift in exact operating position. Make sure the complete base of the lift is in contact with the floor. Where there is no contact, base may be shimmed or grouted to make contact.
- c. All stationary lifts are provided with anchor holes in the base. It is recommended that stationary lifts be bolted in place (see figure 4).

CAUTION!

Lifts with oversized tabletops must be secured to the floor with 4 anchor bolts with a minimum of 1000 lbs. pullout strength for each bolt.

C. HYDRAULICS

1. Use only hydraulic oils for these lifts. The lift has been supplied with Citgo AW32. When adding fluid, use only the recommended oils listed in Table 1.
2. Before using, check oil level and fill if necessary. Check fittings for tightness. See Troubleshooting (see Section 7).

CAUTION!

XF & XP Scissor lifts are designed for normal factory environments. Where low or below freezing temperatures may occur, special fluid must be used (consult service department).

WARNING!

Do not use automotive hydraulic, brake or transmission fluids. They will damage seals and pose a serious fire hazard.

D. TESTING THE LIFT WITH NO LOAD:

1. Before testing the lift, clear the area of packaging and loose material. Be sure there are no obstructions above the lift. Turn flow control knob clockwise and counter clockwise to verify proper installation- clockwise will reduce flow and close the valve. With the valve partially opened (1/2 turn), pump the pedal several times. The unit should rise. If the lift does not rise, review procedures. If necessary consult Troubleshooting (see Section 7).

CAUTION!

Do not over tighten the flow control knob. It may cause damage to the needle valve seat or strip the control knob from the shaft assembly. To lower lift, open the control valve slowly by turning the knob counterclockwise and observe lift lowering speed. The greater the turn, the greater the lowering speed.

SECTION 4

OPERATION

A. METHOD OF OPERATION:

FOOT PUMP

The XF & XP scissor lifts are equipped with a pump assembly and individual flow control mechanism.

To raise the lift, close the flow control knob clockwise. Depressing the foot pedal fully will pressurize the cylinder. This will cause the cylinder to extend. The scissor will separate and thereby raise the tabletop. When the foot pedal is released, a spring will return the pedal to its original position and a check valve built into the pump will hold the table in an up position. The spring return stroke draws oil from the reservoir through a check valve, keeping the oil in the piston preparatory to its next lifting stroke.

To lower the lift, the flow control is opened by turning the knob counter clockwise slowly.

CAUTION!

Opening or closing the flow control valve quickly will cause impact loading, which more than doubles the load effect on the lift and can cause serious damage.

B. OPERATION PROCEDURES:

In order to operate the lift, follow these operating procedures:

1. Read and understand all the instructions before operating. If the lift has modifications or accessories, read and understand their instructions.
2. Load the lift correctly.
 - a. Portable lifts: Place the load on the center of the tabletop. The load, center of gravity, must be within 6" of the lift tabletop center and equally distributed over 80% of the table.
 - b. Stationary lifts: Place the load on the center of the tabletop. The load, center of gravity, must be within 8" of the lift tabletop center and equally distributed over 80% of the table.
 - c. If the load is unstable or table may become unstable, fasten it into position.
 - d. For side and end loads, see derating chart (Table 2).

3. Operate the lift (foot pump)
 - a. To raise lift, close flow control valve and pump foot pedal.
 - b. To lower lift, open flow control valve carefully.
4. Wait until the lift has come to a complete stop before unloading lift.
5. Stand clear of lift when operating it in order to avoid injury.

WARNING!

- **Do not stand, sit or climb onto the lift.**
- **Do not load or unload a moving lift.**
- **If the lift fails to move or exhibits strange movement or sound, stop immediately.**
- **Do not operate the lift until it has been checked and repaired.**
- **Obey all warning labels.**
- **Do not exceed maximum rated load.**
- **Maintain load within 80% of the lift platform area. The center of gravity of the load must be located within 6” of the center of the platform for portable lifts and 8” for stationary lifts.**

SECTION 5 MAINTENANCE

Generally, the XF & XP series scissor lifts will require little maintenance. However, routine maintenance and inspection will minimize costly repairs or hazardous conditions.

WARNING!

**Never go under or service a lift with the scissor mechanism unblocked.
If possible, service the lift in a down position.**

A. ROUTINE MAINTENANCE:

All routine maintenance should be performed monthly. Maintenance should be performed on the standard XF & XP series scissor lifts with standard tops, in a lowered height position. Raise the top to its over center position (see figure 6), secure in place and perform the routine listed checks (1 – 5).

For lifts with oversized platforms, the lift must be serviced in an up position. The following procedure must be followed prior to servicing:

- a. Raise the lift to the full up position.
- b. Place the appropriate chock in position as shown in figure 1 and figure 6.
- c. Lower the lift until the rollers come in contact with the chock.
- d. Perform the routine listed checks (1-5)

WARNING!

Wood blocks should be cut to the proper length and be of a hard wood variety. Check for defects or damage to the blocks prior to each usage.

B. ROUTINE CHECKS:

1. Check oil level. Add oil if necessary according to Troubleshooting (see Section 7).
2. Check rollers for signs of wear. Replace if damaged.
3. Check hydraulic lines for damage or leaking. Replace if damaged.
4. Check for oil spots on floor. Trace leak to determine proper repair.
5. Bearings on all lifts are permanently lubricated and under normal usage require no servicing.

C. TROUBLESHOOTING- FOOT OPERATED (see page 9).

SECTION 6

SERVICE

A. REPLACING CYLINDER SEALS:

(Seal kits are listed on page 10)

1. Lower the lift to its lowest position, then lift the top to its over center position and secure.
2. For lifts with oversized platforms, the cylinder is replaced while the lift is in an up position. To position lift in the up position, follow instructions for routine maintenance (5A a-c).
3. Disconnect the hydraulic hose from the cylinder and cap the line to prevent hydraulic fluid loss.
4. Loosen the set screws holding the cylinder pin.
5. Remove the cylinder pin.
6. Lift the cylinder out of the lift.

CAUTION!

Hold the cylinder securely while removing the pin to prevent it from falling to the floor.

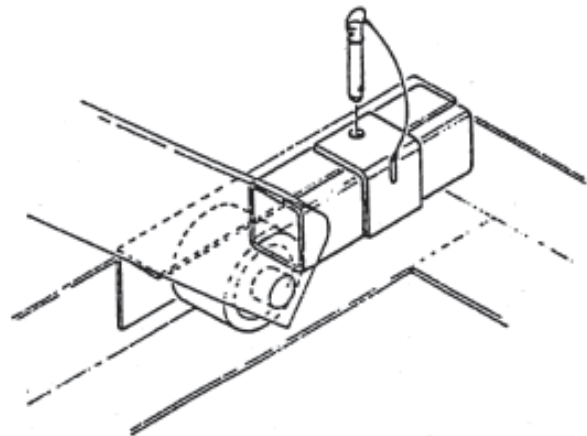
7. Clamp cylinder securely at the base end.
8. Completely collapse cylinder piston.
9. Push gland into the cylinder 1/8" - 3/16".
10. Remove retaining ring.
11. Remove piston rod, piston and gland from cylinder.
12. Remove rod nut, piston and gland.
13. Remove and replace seals and wipers.
14. Assemble piston and gland to piston rod.
15. Assemble rod nut to piston rod and torque to 100 ft./lb.
16. Lubricate piston and seals and install in cylinder.
17. Insert retainer ring.
18. Install cylinder, cylinder pin, set screws and hydraulic lines.
19. Fill reservoir.
20. a). For the lifts serviced in lowered position, lower tabletop completely.
b). For the lifts serviced in the up position, raise table and remove chocks.
21. Cycle lift 2-3 times adding oil if necessary.
22. Recheck reservoir oil level.

B. REPLACING LEG ROLLERS

(Kit is listed on page 10)

1. a). For standard lifts, lower lift to its lowest position and hold down switch for an additional 10-20 seconds. Then lift the top to its over center position and secure.
b). For lifts with oversize or beveled platform secure the lift as follows: Raise the lift to its full raised position. Place a steel 7/8" or 1" bar through both outer scissor leg holes. Lower the lift until the inner legs are firmly in contact with the bar.
2. Raise the leg assembly 2" and support with the yellow supplied safety chock.
3. Remove retainer clips, shield and rollers.
4. Clean and lubricate axle. Replace with new rollers, shields and clips.
5. a). For lifts serviced in a lowered position lower the tabletop completely.
b). For lifts serviced in the up position, raise table slightly and remove steel bars.

**FIGURE 1:
MAINTENANCE CHOCK**



SECTION 7
TROUBLESHOOTING

TROUBLESHOOTING : FOOT OPERATED		
PROBLEMS	PROBABLE CAUSE	SERVICE REQUIRED
Lift will not rise.	Low fluid.	Check fluid level. (1)
	Pump/air lock	Open flow valve and cycle pump. (2)
	Leak in suction line.	Check suction line from reservoir and pump for misconnects or leaks.
	Faulty Flow Control Valve.	Replace.
Lift raises, then slowly lowers.	Pump	Remove check ball and spring. Inspect valve seat. Clean and replace.
	Leaking fitting	Check fittings and lines for telltale oil spots.
	Faulty flow valve.	(3)

1. On right hand side of caster plate you will find a square head plug.

- Remove the plug and fill oil well with hydraulic oil. Oil level should be between 3/4" to 1" from the top.

2. Priming Hydraulic system.

- Remove item #6 (lock rings) and remove item #5 (lever pin). (See Fig. 2)

Place a screwdriver through hole in top of pump where item #5 (lever pin) was installed in top of pump. Cycle pump by pulling the pump shaft up and then push back down until pump is primed. This may require several cycles to prime pump. Reassemble foot pump in reverse order.

3. If the lift tends to creep downward under a load. A speck of dirt may be obstructing the seating of the valve and allowing leakage. To correct, follow these instructions:

- Raise lift to full lifting height and then lower it to lowest point of lift. It may be necessary to do this five or six times. In lowering the lift, lower it in stages, that is, lower the lift six inches to a foot at a time. This will dislodge the dirt and lift will operate properly.
- If this does not correct the problem, replace valve.

STANDARD REPLACEMENT PARTS:

Description	Part #	Used on
Cylinder	1001-171-01	XP24-15
	1001-171-02	XP36-15
	1001-171-03	(W)XF24-10 & (W)XF24-15
	1001-171-04	(W)XF36-10 & (W)XF36-15
	1001-171-05	XP24-10
	1001-171-06	XP36-10
Cylinder seal kit	1001-048	Cylinder P/N 1001-171-01, -02, -03, -04
	1001-049	Cylinder P/N 1001-171-05, 1001-171-06
Roller kit	1000-067VR	All
Wheels:		
Swivel Caster w/ 5" x 2" Wheel	C101PH5	All XP
Swivel Caster w/ Wheel Lock	C101PH5L	All XP
5" x 2" Wheel Assembly	C102PH	All XP
Foot Pump (see fig. 2)	1010-024	All XP, XF
Pump Body	1010-025	
Pump Spring	1010-009-01	
Pump Clip	M404	
Pump Fulcrum Pins	1010-008	
Pump Lever Assembly	1010-007VR	
Foot Lever	M436	
Foot Lever Pad	M437	
Release Rod assembly	1010-017-01	XF24, XF36, WXF24, WXF36
	1010-017-02VR*	XP24, XP36, WXP24, WXP36
	80001612**	All XP, WXP
	80001614VR**	All XF, WXF
Down Flow Valve	1010-019-01*	All XF, WXF, XP, WXP
	2533080**	All XF, WXF, XP, WXP
Black Knob	1010-019A	All XP, XF
Floor lock	77248-6	All XP, WXP

* Prior to 10/6/04

** 10/6/04 and later

**FIGURE 2:
FOOT PUMP ASSEMBLY**

ITEM NO.	PART NO.	DRW NO.	QTY.	DESCRIPTION
1	1010-007VR	1010-007	1	LEVER ASSEMBLY
2	M436	48	1	FOOT LEVER
3	M437	49	1	FOOT LEVER PAD
4	1010-009-01	1010-009	1	COMPRESSION SPRING
5	1010-008	45	1	LEVER PIN
6	PSL28A	44	4	LOCK RING
7	1010-025	1010-025	1	FOOT PUMP SUBASSEMBLY
8	1001-204	1001-204	1	CAP, SPRING

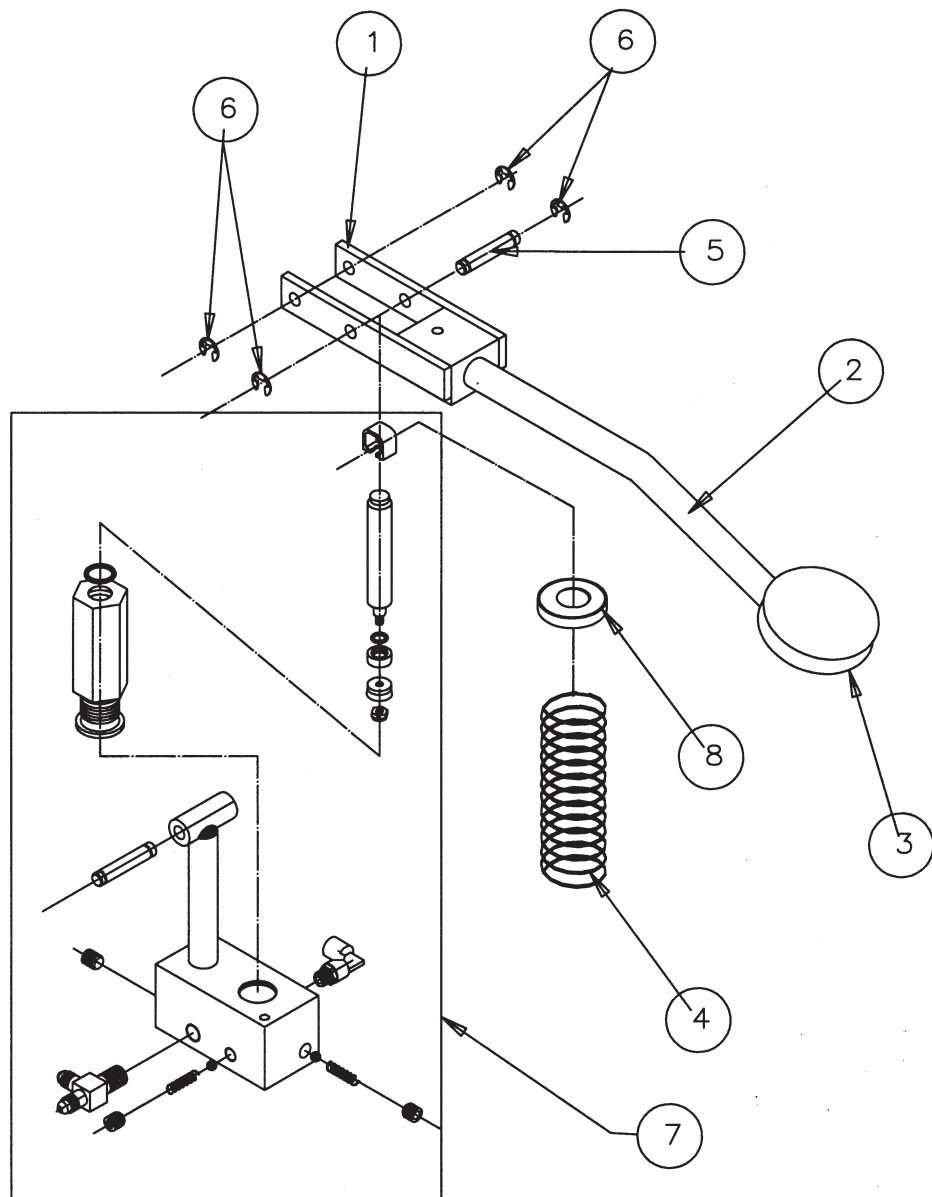
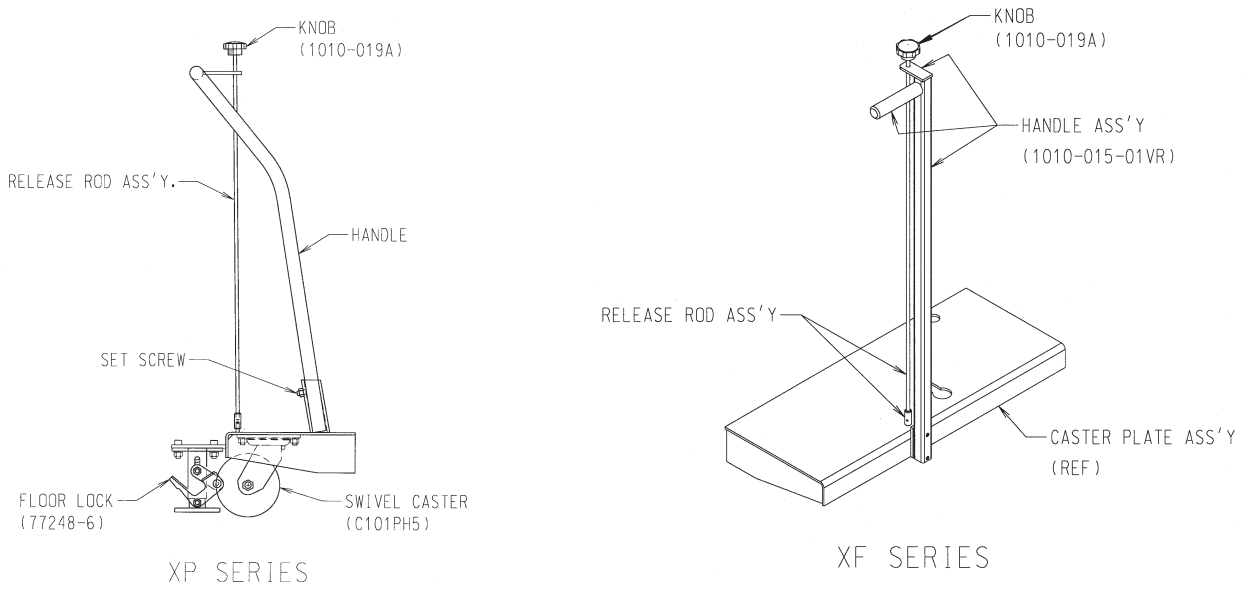
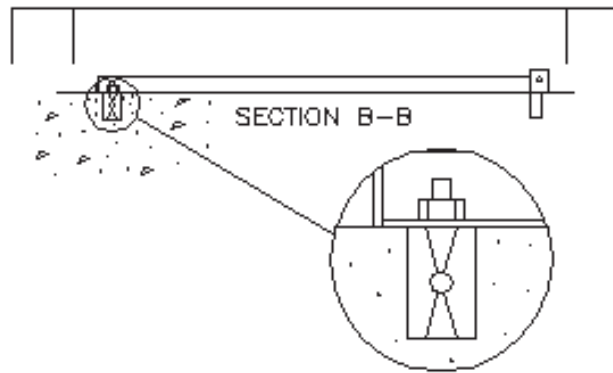


FIGURE 3: HANDLE/CASTER PLATE ASSEMBLY



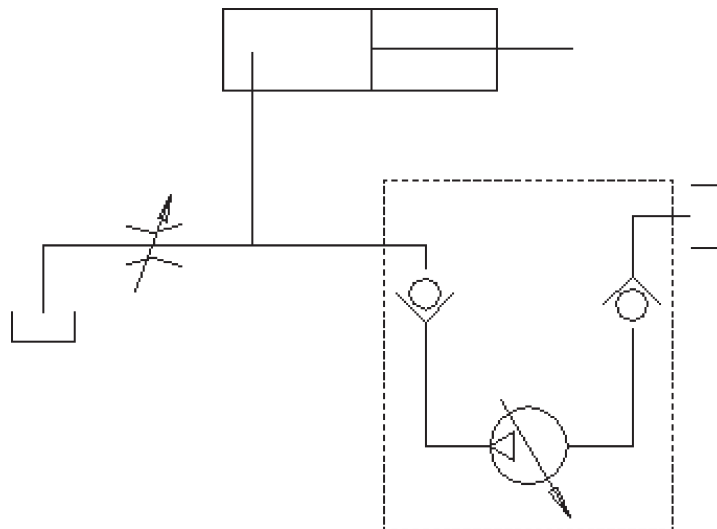
**FIGURE 4:
ANCHOR BOLT
DETAIL**

Side view of scissor lifting table showing anchor bolt details.

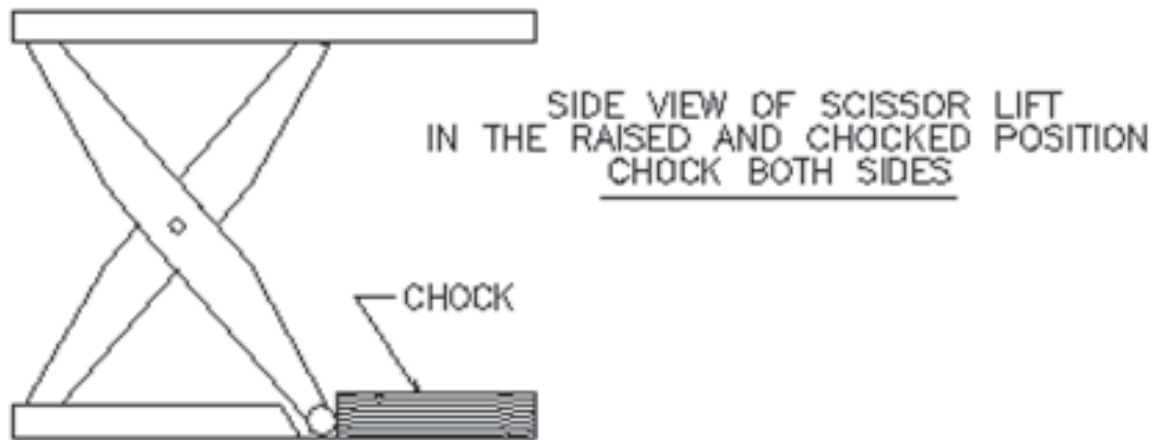
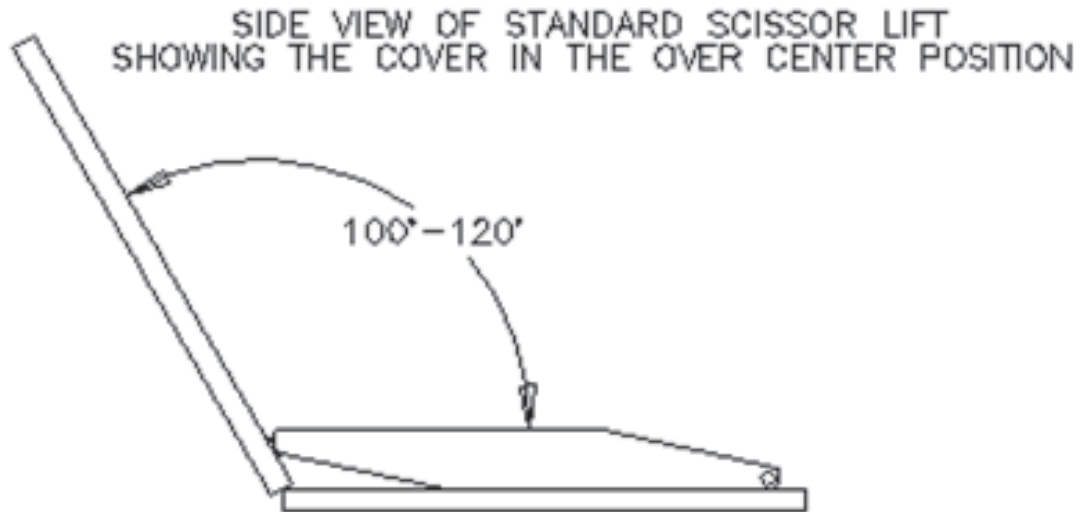


**FIGURE 5:
HYDRAULIC SCHEMATIC**

Hydraulic Pump Foot Operated
Undirectional Piston Pump
These pumps are foot actuated piston to power single acting cylinder. Locking check holds the load in the up position. Adjustable orifice controls the down rate cycle of the lift.



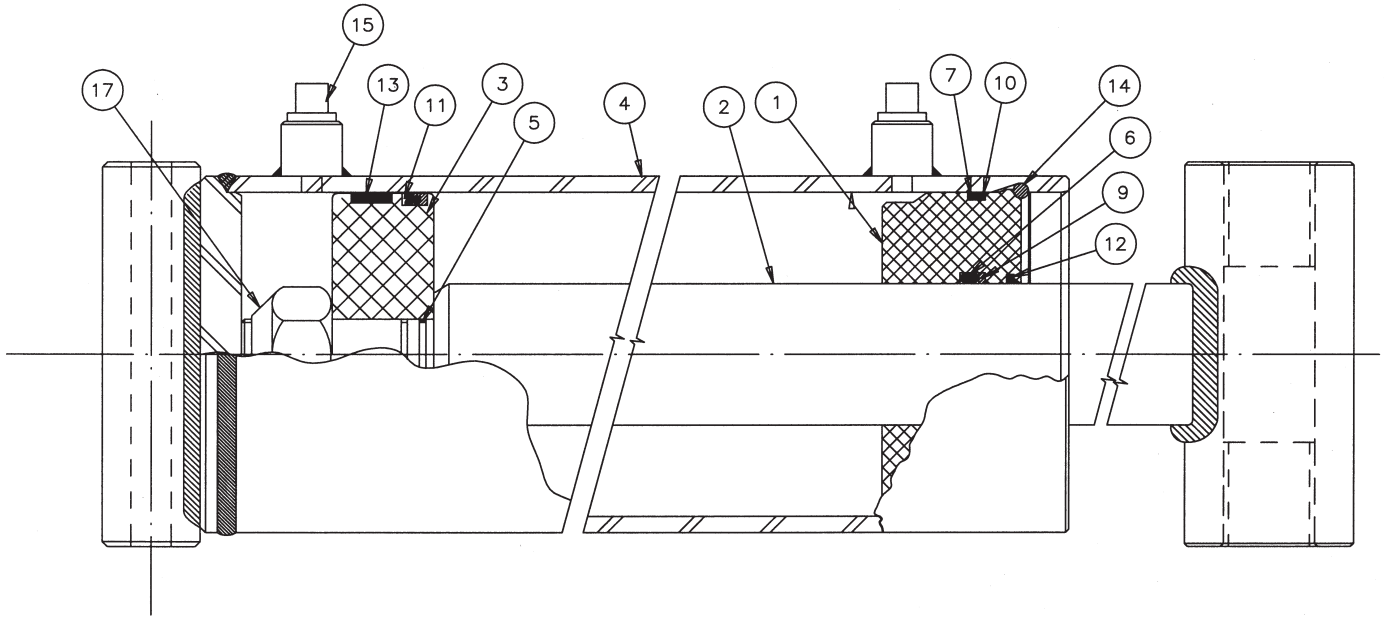
**FIGURE 6:
MAINTENANCE POSITION**



CHOCK SIZES: 2 REQUIRED LIFT

LIFT TRAVEL 24"	2x4x14"LONG
LIFT TRAVEL 36"	2x4x20"LONG

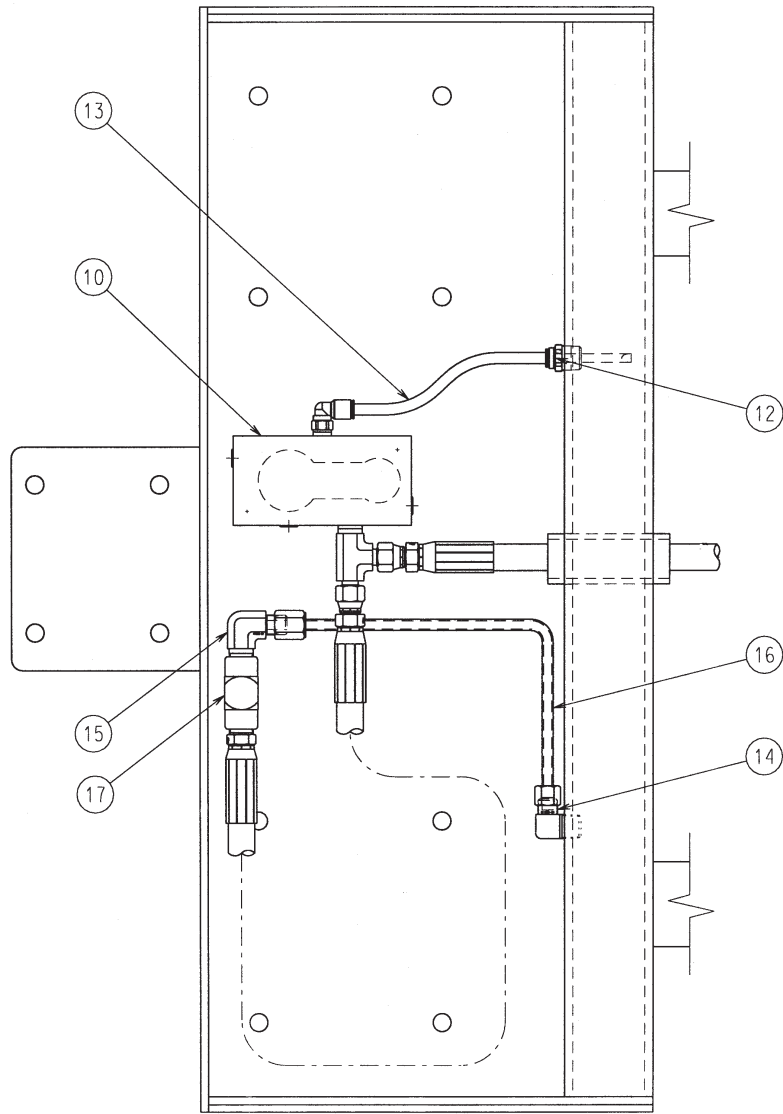
**FIGURE 7:
CYLINDER ASSEMBLY - 1001-171 Series**



ITEM NO.	DESCRIPTION	QUANTITY
17	LOCKNUT	1
15	CAPLUG	1
14	RETAINING RING	1
13	WEAR RING	1
12	ROD WIPER	1
11	U-CAP/TYPE D	1
10	BACKUP RING	1
9	BACKUP RING	1
7	O-RING	1
6	O-RING	1
5	O-RING	1
4	BARREL ASSEMBLY	1
3	PISTON	1
2	ROD ASSEMBLY	1
1	GLAND	1

**FIGURE 8:
HYDRAULIC SYSTEM
UNDER
CASTER PLATE**

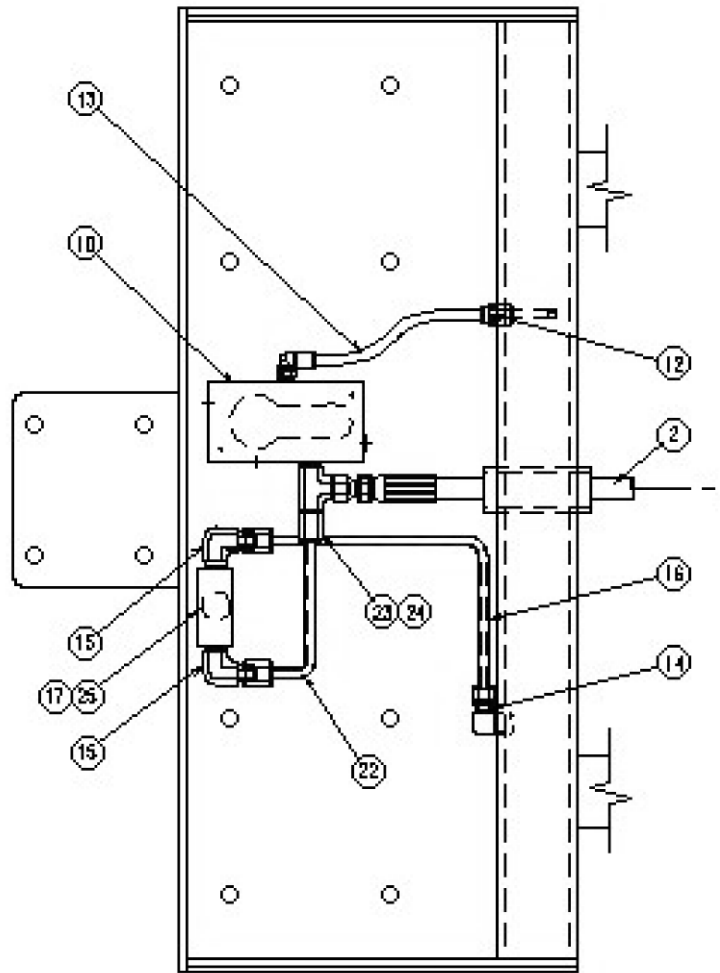
Prior to 10/6/04 and S/N V13556



ITEM NO.	QTY	DESCRIPTION
17	1	VALVE
16	1	TUBE
15	1	FITTING
14	1	FITTING
13	.33 FT	TUBE
12	1	CONNECTOR
10	1	FOOT PUMP

FIGURE 9:
HYDRAULIC SYSTEM
UNDER
CASTER PLATE

After 10/7/04 and S/N V13556



ITEM NO.	PART NO.	QTY	DESCRIPTION
25	10030028	1	NUT, CASTER PLATE
24	2411117	1	FERRUL, TUBE
23	2411111	1	NUT, TUBE
22	1067003	.5 FT	TUBE
17	2533080	1	VALVE
16	30000228	1	TUBE
15	H103B-02	2	FITTING
14	H103B-01	1	FITTING
13	H115-2000P	.33 FT	TUBE
12	H102B-2000	1	CONNECTOR1
10	1010-025	1	FOOT PUMP
1	80001022	1	HOSE ASSEMBLY

TABLE 1 – Hydraulic Oil Specifications

If the lift will be used at normal ambient temperatures, Presto Lifts supplies the unit with Citgo AW 32 oil. This may be replaced by any other good quality oil with 150 SSU at 100° F and rust and oxidation inhibitors and anti-wear properties. If the lift will be used at ambient temperatures below 0°F, use aircraft hydraulic oil. Use Type 15 aircraft hydraulic oil.

The following are equivalent to CITGO AW32:

TYPE	MANUFACTURER
DTE 24	EXXON/MOBIL
NUTO H32	EXXON/MOBIL
AMOCO AW32	CHEVRON (AMOCO CO.)

CAUTION!

It is very important to keep the hydraulic oil free of dirt, dust, metal chips, water, and other contamination. Most of the problems with hydraulic systems are caused by contamination in the oil.

TABLE 2 - Standard Specifications And Derating Chart

Model #	Capacity	Lowered Height	Raised Height	Standard Platform	End/ Side Capacity	Oversize Platform	
						Maximum	End/side
XP24-10	1000 lbs.	9-1/4"	33"	24" X 36"	1000 lbs.	30" x 42"	880 lbs.
XP24-15	1500 lbs.	9-1/4"	33"	24" X 36"	1500 lbs.	30" x 42"	1320 lbs.
XP36-10	1000 lbs.	9-1/4"	45"	24" X 48"	1000 lbs.	30" x 54"	880 lbs.
XP36-15	1500 lbs.	9-1/4"	45"	24" X 48"	1500 lbs.	30" x 54"	1320 lbs.
	See #1				See #1		See #3
XF24-10	1000 lbs.	5-1/4"	29"	24" X 36"	1000 lbs.	30" x 42"	760 lbs.
XF24-15	1000 lbs.	5-1/4"	29"	24" X 36"	1500 lbs.	30" x 42"	1140 lbs.
XF36-10	1000 lbs.	5-1/4"	41"	24" X 48"	1000 lbs.	30" x 54"	760 lbs.
XF36-15	1000 lbs.	5-1/4"	41"	24" X 48"	1500 lbs.	30" x 54"	1140lbs.
	See #2				See #2		See #4

NOTE #1: Capacity is based on the load center of gravity, being within 6’ of the lift center and equally distributed over 80% of the table.

NOTE #2: Capacity is based on the load center of gravity being within 8’ of the lift center and equally distributed over 70% of the table.

NOTE #3: Capacity is based on the load center of gravity being within 9’ of the lift center and equally distributed over 70% of the table.

NOTE #4: Capacity is based on the load center of gravity being within 12’ of the lift center and equally distributed over 60% of the table.

RESTOCKING POLICY

Presto Lift, Inc.'s goal is for you to be satisfied with your order. Merchandise may be returned, but returns will be subject to a restocking fee to cover the costs Presto Lift, Inc. incurs which include but are not limited to handling, storage of the units, etc. Presto Lift, Inc. will issue refurbishing costs where end-user wear is apparent. We would prefer to not charge for these costs but find it necessary and apologize for any inconvenience. Please review the RETURN MATERIALS AUTHORIZATION (RMA) PROCEDURES.

LIFTS

Lifts may be returned with a restocking fee according to the following schedule:

1. Standard unit or standard unit with stock options:

Three or less	20%
With re-order	20%
Four or more of the same model	Consult Customer Svc.
With re-order	Consult Customer Svc.
2. Custom engineered/modified lifts: **No Returns**

PARTS

Standard parts may be returned with a 20% restocking fee. Modified or custom-engineered parts are not returnable. Unfortunately, due to potentially concealed damage, all sales of electrical assemblies are final.

QUALITY ISSUES

Should you feel there is a quality problem, please contact the seller to ask questions and gather information on how to rectify the issue. Presto Lift Inc. reserves the right to determine potential credits, as a result of factory defects, based on its inspection of the merchandise.

GENERAL

All products shipped from our factory have passed Quality Assurance inspection and testing. The carrier of choice has signed for, and accepted the product in new working condition. The customer should inspect to ensure it is not received damaged, has no concealed damage or is not incomplete. Parts orders are determined to be complete based upon Presto Lift, Inc. inspection sheets and carrier shipping weights.

RETURN MATERIALS AUTHORIZATION (RMA) PROCEDURES

Although Presto Lift, Inc. is not legally obligated to issue a credit for any merchandise, the RETURN MATERIALS AUTHORIZATION (RMA) PROCEDURE is provided as a courtesy to our customers in the event they do not receive what they wanted.

If a customer wishes to return a Presto Lift, Inc. product, the first step in the process is to request an RMA number from Presto Lift, Inc.'s Customer Service Department. This request must be made on or before the thirtieth (30th) calendar day following the date of Presto Lift, Inc.'s invoice for the merchandise being returned.

The RMA number must appear on the outside of any packaging material for a return to be accepted and processed by Presto Lift, Inc. Customers shipping returns back to Presto Lift, Inc. from the Continental US, Canada and Mexico have fourteen (14) days from the effective date of the RMA to have the merchandise arrive freight prepaid at Presto Lift, Inc. Returns from locations other than the Continental US, Canada and Mexico must be shipped within the fourteen (14) day period to arrive Free On Board (FOB) at Presto Lift Inc as soon as practical. If a customer believes Presto Lift, Inc.'s merchandise is defective, freight will be reimbursed to the original "Bill To" on the invoice if Presto Lift Inc. finds that the merchandise is defective.

Please remember that merchandise with RMAs coming back to Presto Lift Inc. from the Continental US, Canada and Mexico will not be accepted by Presto Lift Inc. if the returned goods do not arrive freight prepaid at Presto Lift Inc. within the fourteen (14) day effective period.

All credits issued are less restocking fees as applicable, plus any assessed outbound/inbound in-transit damages.

Return addresses: please refer to your RMA for the address to which your product should be returned.

Presto Lifts Inc.
715 Highway 77
Manila, Arkansas 72442

Telephone: 800-343-9322
Fax: 888-788-6496

Ordering Replacement Parts

Presto Lifts has carefully chosen the components in your unit to be the best available for the purpose. Replacement parts should be identical to the original equipment. Presto Lifts will not be responsible for equipment failures resulting from the use of incorrect replacement parts or from unauthorized modifications to the unit.

Presto Lifts can supply all replacement parts for your lift. With your order, please include the model number and the serial number of the unit. You can find these numbers on the name plate. This plate is located within the scissors mechanism.

To order replacement parts, please call the Presto Parts Department. Parts are shipped subject to the following terms:

- FOB factory
- Returns only with the approval of our parts department.
- Credit cards preferred (except parts covered by warranty).
- Freight collect for truck (except parts covered by warranty).
- Freight – prepaid and invoice for small parcel shipments (except parts covered by warranty).

Parts replaced under warranty are on a “charge-credit” basis. We will invoice you when we ship the replacement part, then credit you when you return the worn or damaged part.

Presto Parts Department

21 Park Street
Attleboro, MA 02703

Telephone: 800-343-9322

FAX: 888-788-6496

Email: service@PrestoLifts.com

www.PrestoLifts.com

Presto Lifts Limited Warranty Policy

Presto Lifts warrants all of its products against defects in the welded structural frame and, if applicable, scissor legs from faulty material and workmanship for a period of five (5) years from the date of invoice.

A lifetime limited warranty is provided for the Airstroke Actuator™ in all pneumatic lifts against any defect due to faulty material or workmanship.

All batteries are covered under a separate limited warranty from the battery manufacturer for a period of one year from the date of invoice.

All other components have a limited warranty against defects in faulty material and workmanship for a two (2) year period from the date of invoice date of invoice and 30 day limited warranty on labor. Please note that prior authorization from Presto Lifts is required on all warranty work.

There are no implied warranties of any kind, more specifically, there are no warranties of merchantability or fitness for any particular purpose. Presto Lifts' sole warranty shall be as set forth in this limited warranty.

Presto Lifts will elect to repair or replace a defective component without charge, if any components should become defective within the limited warranty period. Proof of purchase is required for warranty. The charge for shipping the defective component is the responsibility of the buyer and must be accompanied with an RGA number. The shipping charge to return the component to the buyer is the responsibility of Presto Lifts, Inc.

This limited warranty does not cover labor expense for removal or reinstallation of components after thirty days. This limited warranty shall not cover, among other things: damages resulting from foreign matter or water, failure to provide reasonable and necessary maintenance, and if applicable, use of product while charger is plugged into an AC outlet, or failure to follow operating instructions. The limited warranty is not valid for damage resulting from negligence, accident, unreasonable use, abuse or misuse, exceeding data plate capacities or altering the product without Presto Lifts authorization.

Presto Lifts expressly disclaims and excludes any liability for consequential, incidental, indirect or punitive damages or financial loss to people or property resulting from any breach of warranty or the operation or failure of this product.

Presto Lifts makes no representation that this product complies with local, state, or federal safety/product standards codes. Should this product fail to comply in any way with those codes, it shall not be considered a defect of materials or workmanship. Presto Lifts shall not be held liable for any damages resulting from noncompliance. It is the dealer's responsibility to exercise this limited warranty. This limited warranty is provided to the original purchaser (defined as the original end user) and is nontransferable. This constitutes the complete and final agreement involving Presto Lifts and limited warranty obligations for products.

Go Presto LIFTS™

MANY NEEDS REQUIRE
MANY OPTIONS...



Lift
Stik



Post Tables



Double Lift
Table



Lift Table



Portable
Lift



P3



Counterweight
Stacker



Pallet Jack



Pneumatic Lift/Tilt

Call Presto Sales
for stock or customized lift inquiries at

800-343-9322

Email: sales@prestolifts.com



Portable Tilter



Floor Level Lift



Stacker