

XS, DXS & WXS Series Scissor Lifts

Installation, Operation and Service Manual

Model Number _____

Serial # _____

Date placed in service _____

**IMPORTANT: READ CAREFULLY
BEFORE INSTALLING OR OPERATING LIFT**

Part orders are subject to a \$50 minimum charge.



This manual was current at the time of printing. To obtain the latest, most updated version, please contact Presto Lifts Customer Service Department or go to our website: www.PrestoLifts.com -- you will find a complete list of current owner's manuals to print.

CONTENTS

SECTION 1:	
Introduction.....	4
SECTION 2:	
Safety	4
SECTION 3:	
Installation.....	4
A. Uncrating and Inspection	4
B. Installing.....	5
C. Electricals.....	5
D. Hydraulics	5
E. Testing the Lift with No Load	5
SECTION 4:	
Operation.....	6
A. Method of Operation.....	6
B. Operating Instructions.....	6
SECTION 5:	
Maintenance.....	6
A. Routine Maintenance	6
B. Troubleshooting Maintenance.....	7
SECTION 6:	
DXS Lifts	8
ORDERING REPLACEMENT PARTS.....	14
RESTOCKING POLICY.....	15
RETURN MATERIALS AUTHORIZATION (RMA) PROCEDURES.....	16
WARRANTY.....	17

LIST OF FIGURES :

Fig. 1 Electrical Diagram 115V	9
Fig. 2 XS & WXS Components Diagram.....	10
Fig. 3 DXS Components Diagram.....	11
Fig. 4 DXS Power Unit.....	12
Fig. 5 Hydraulic Schematic (All models)	13

LIST OF TABLES :

Table 1 Troubleshooting Maintenance - Electrical.....	8
Table 2 Hydraulic oil Specifications.....	13

SECTION 1

INTRODUCTION

This manual attempts to provide all of the information necessary for the safe and proper installation, operation and maintenance of Presto Lifts Inc.'s XS, DXS & WXS Series Scissor Lifts. It is important that all personnel involved with the installation, maintenance or operator of the scissor lift read this manual. Where unique situations arise, that are not covered in this manual call Presto Lifts for further instructions. Additional manuals are available upon request or on our web site at www.prestolifts.com.

The scissor lift has a nameplate that provides the load capacity ratings, serial number and model identifications. Please refer to these numbers when ordering parts or requesting further information.

The Presto Lifts XS, DXS & WXS Series Scissor Lifts are designed for lifting, lowering and positioning a variety of loads. WHERE UNIQUE SITUATIONS ARISE, THAT ARE NOT COVERED IN THIS MANUAL, CALL PRESTO LIFTS FOR FURTHER INSTRUCTIONS.

The XS, DXS & WXS Series Scissor Lifts is designed for inplant/nonhazardous location use only. These units are not for personnel lifting.

SECTION 2

SAFETY

The XS, DXS & WXS Series Scissor Lifts are very powerful lifts capable of doing large amounts of work. They contain scissor legs, that are hydraulically actuated and are capable of causing serious injury or damage if adequate precautions are not taken.

DO NOT INSTALL OR OPERATE THESE LIFTS WITHOUT CAREFULLY READING THIS MANUAL. In order to provide for the safe operation of these scissor lifts, Presto Lifts Inc. has identified certain hazards that may occur during the installation, maintenance and use of these lifts. **For safety reasons the standard XS, DXS & WXS Series Scissor Lifts are designed to be serviced or repaired in the lowered position.** If performed properly, this will greatly reduce the pos-

sibility of injury. Lifts with oversize table tops require special handling (See Section 5, Maintenance).

WARNING!

- Do not perform any repair work on lifts if there is a load on the platform or with the table in a raised position.
- All personnel must stand clear of the lift when the lift is in motion.
- Do not put hands or feet under the lift table.
- Do not work under the table without securing the lift with supplied safety chocks.
- Do not stand, sit or climb on the lift.
- Do not use the lift on soft, uneven or unstable surfaces.
- Do not exceed the load capacity.
- Do not place a load on a moving lift.
- Place loads in the center of the table and secure loads properly.

SECTION 3

INSTALLATION

A. UNCRATING AND INSPECTION:

Upon receipt of the XS, DXS & WXS Series Scissor Lifts, inspect the equipment completely to determine if there is any shipping damage, and that the lift is complete. Presto Lifts Inc. tests and inspects every piece of equipment prior to shipment. If damage is apparent, a freight claim must be filed with the freight company. Do Not use the lift if there appears to be any damage. With the lift in a collapsed position, check the following:

CAUTION!

Lifts with oversize table tops must not be over extended since doing so may disassociate the cylinder base from its socket. (See Section 5, Maintenance).

1. Check for signs of damage especially to the electrical and hydraulic components.
2. Check all connections for tightness.
3. Check for any bent or damaged metal parts.
4. Check base frame for flatness.

CAUTION!

When moving the lift, do not attempt to pick it up

by the table top. The lift should be picked up by its base only.

B: INSTALLING:

Before starting, be sure that the electrical system is wired and is in full compliance with local electrical codes and ordinances. Read all of the instructions prior to starting the lift.

1. Handle Assembly

- a). Portable lifts have the push handles removed for ease of shipping. Handles should be inserted in the holders until they bottom out then tighten set screws on each holder with an Allen wrench.

2. Floor Installation

- a). Electrical connections must be made according to the electrical schematics and information contained in Section 3C and in compliance to local codes and ordinances.

C. ELECTRICALS:

1. The motors on XS, DXS & WXS Series Scissor Lifts are special intermittent duty motors with high pull up torques. These motors require heavier duty electrical controls than standard motors.
2. Wiring circuits must conform to local codes and must be installed by a licensed electrician.
3. Lifts are pre-wired at the factory for motor direction and performance.

CAUTION!

All wiring must conform to local codes and must be performed by licensed electricians.

WARNING!

Do not attempt to modify or change the electrical circuit. Any alterations will cause damage to the pump and possible physical injury. Only authorized personnel should service the electrical system.

4. For the XS, DXS or WXS Series Scissor Lifts, a dedicated circuit of 20 amps or larger will suffice to operate the lift.

D. HYDRAULICS:

1. Use only hydraulic oil for the lift. The lift has been supplied with Conoco Super Hydraulic 32. When adding fluid, use only the recommended oils. See Table 1.
2. Before using the lift, check the hydraulic oil level and add oil if necessary. Check fittings for tightness. If the plug is not installed, you may damage the pump.

CAUTION!

XS, DXS & WXS Series Scissor Lifts are designed for normal factory environments. Where below freezing conditions may exist, special fluid must be used. Contact Presto Lifts for further information when freezing conditions exist.

E. TESTING THE LIFT WITH NO LOAD:

1. Before testing the lift, clear the area of any loose material. Be sure the lift has no obstruction above it or on any side.
2. Using the controls provided, briefly operate the lift (5-10 seconds). If the lift begins to rise with a humming sound and functions properly, continue to the full upright position.

CAUTION!

If the lift does not rise immediately, or there is any operational problem, stop it immediately. Before continuing, check the rotation of the pump and motor and the voltage at motor terminals; again briefly operate the lift. If the lift does not move smoothly with a humming sound, stop and review the procedures in the section on troubleshooting (5B).

3. After raising the lift completely, lower the lift. It should move slowly and smoothly with a humming sound. If the lift operates properly, raise and lower the lift and stop at different levels to get a good perspective on the lift's operations and movements.

SECTION 4

OPERATION

A. METHOD OF OPERATION:

All XS, DXS & WXS Series Scissor Lifts are provided with a special relief valve and are factory preset for the maximum safe capacity of the lift. Activating and holding the up switch will energize the motor. The motor is attached to a positive displacement pump, that draws hydraulic fluid from the reservoir and transfers it under pressure to the cylinder. This forces the piston forward and the scissor legs to separate and raise the platform, releasing the up button will stop the lift. A check valve between the pump and piston holds the table in position. Depressing and holding the down switch will energize a solenoid, that allows the oil from the cylinder to return to the reservoir through a preset flow control. This allows the lift to lower smoothly and at a controlled speed.

CAUTION!

Do not attempt to change the setting on the pressure relief valve. Do not maintain the up or down button energized if the lift fails to move or after it has reached its up or down limits. This will cause damage to the pump and controls.

B. OPERATING INSTRUCTIONS:

In order to operate the lift follow these operating procedures.

Read and understand all the instructions before operating. If the lift has modifications or accessories, read and understand their functions.

1). Load the lift correctly.

Portable lifts: Place the load on the center of the table top. The load center of gravity must be within 6" of the lift table top center and equally distributed over 80% of the table.

Stationary lifts: Place the load on the center of the table top. The load center of gravity must be within 8' of the lift table top and equally distributed over 80% of the table.

If the load is unstable or may become unstable, fasten it into position.

- 2). Operate the lift.
 - a) To raise the lift, press and hold the up button.
 - b) To lower the lift, press and hold the down button.
 - c) Release the button to stop the lift.
- 3). Wait until the lift has come to a complete stop before unloading the lift.
- 4). Stand clear of lift when operating it in order to avoid injury.

WARNING!

- a). **Do not stand, sit or climb onto the lift.**
- b). **Do not load or unload a moving lift.**
- c). **If the lift fails to move or exhibits strange movements or sound, stop immediately. Do not operate the lift until it has been checked and repaired.**
- d). **Obey all warning labels.**
- e). **Do not exceed maximum rated load.**
- f). **Maintain load, center of gravity, within 6" of the center of the portable lift and 8" for stationary lifts.**

SECTION 5

MAINTENANCE

Generally, the XS, DXS & WXS Series Scissor Lifts require very little maintenance. Reasonable care will result in excellent trouble-free performance.

WARNING!

Never go under or service lift with a load on the table or with the scissor mechanism unblocked. Always service the lift in a down position.

A. ROUTINE MAINTENANCE:

All routine maintenance should be performed monthly and can be performed on the standard XS, DXS & WXS Series Scissor Lifts in a lowered height position. Before performing any maintenance, shut the power off. Then raise the top over its center position, secure in place and perform the routine listed (1 through 7).

- 1). Check oil level. Add oil if necessary.
- 2). Check rollers for signs of wear. Replace if dam-

- aged.
- 3). Check snap ring and shield. Replace if damaged.
- 4). Check hydraulic lines for damage or leaking. Replace if damaged.
- 5). Check for oil spots on the floor. Trace leaks to the proper fitting and tighten.
- 6). Check wiring for damage. Replace immediately if any sign of wear is evident.
- 7). Bearings on these lifts are permanently lubricated and require no servicing. Look for any signs of wear.

B. TROUBLESHOOTING MAINTENANCE:

LIFT WILL NOT MOVE

1. No operational noises:
 - a). Check power switch, fuses and overloads.
 - b). Check voltage at motor -- motor may have failed.
2. Operational noises:
 - a). Lift may be overloaded or jammed. Check load weight and obstructions.
 - b). Motor (3 phase) single phasing. Check voltage at motor terminals.
 - c). Motor (3 phase) reversed. Reverse 2 lines.
 - d). Motor (1 phase) low voltage. Check voltage at motor terminal.
 - e). Oil shortage -- reservoir low or oil line failure. Repair or replace.
 - f). Down valve open, check wiring, remove and run lift.
3. Motor overheats:
 - a). Excessive cycle rate (15 per hour max.).
 - b). Low voltage -- check voltage at motor.
 - c). Oil starvation -- check filter in reservoir.

LIFT OPERATING SLOWLY

1. Up cycle:
 - a). Oil starvation -- check filter in reservoir.
 - b). Oil viscosity -- oil is too heavy or too thin.
 - c). Air in cylinder -- cycle lift with no load 2 times and hold down button for 20 seconds after bottoming out on each cycle.
2. Down cycle: (single acting cylinders)
 - a). Down valve dirty -- remove and clean. Check oil condition, replace if dirty.

- b). Pinched hydraulic lines.
 - c). Oil viscosity is too heavy.
3. Lift raises, then slowly lowers without power:
 - a). Down valve dirty. Remove and clean.
 - b). Leaking hydraulic lines or fittings (check for telltale oil spots).
 - c). Check valve in pump -- may not be seating. Requires new pump.
4. Lift will not lower when energized:
 - a). Down solenoid faulty. Check voltage -- may be low or wrong voltage for coil. Check continuity of coil (burned out).

LIFT DOES NOT RISE TO FULL HEIGHT Check for leaks or shortage of oil. Maintain the proper oil level. To check oil level, follow these instructions:

IF THE LIFT TENDS TO CREEP DOWNWARD UNDER A LOAD — a speck of dirt may be obstructing the seating of the valve and allowing leakage. To correct, follow these instructions:

- Raise lift to full lifting height and then lower it to lowest point of lift. It may be necessary to do this five or six times. In lowering the lift, lower it in stages, that is, lower the lift six inches to a foot at a time. This will dislodge the dirt and lift will operate properly.

Table 1: TROUBLESHOOTING MAINTENANCE -- ELECTRICAL

PROBLEM	PROBABLE CAUSE	SERVICE REQUIRED
Lift will not move	Loss of power	Check power switch, fuses and overloads or battery and charger.
no motor noise	Motor failure	Check voltage at motor
Lift will not move with motor noise	Overloaded lift Motor	Check load. Low voltage at motor -- Battery low. Oil starvation. Check oil reservoir
Motor overheats	Excessive cycling rate	Check cycle rate, 15 cycles per hour maximum. Low voltage. Check voltage at motor.
Up cycle slow	Oil starvation Oil viscosity Air in cylinder system	Check and fill reservoir. Check oil viscosity and replace if necessary Purge system by cycling several times to full extension and retraction.
Down cycle slow	Blockage in hydraulic line Oil	Check for pinched lines. Oil viscosity too heavy; replace. Oil contaminated; replace.
Lift raises then lowers slowly	Check valve Not seating Leaking fitting	Remove and clean. Check fittings and lines for telltale oil spots.

FIGURE 1: ELECTRICAL DIAGRAM 115 AC

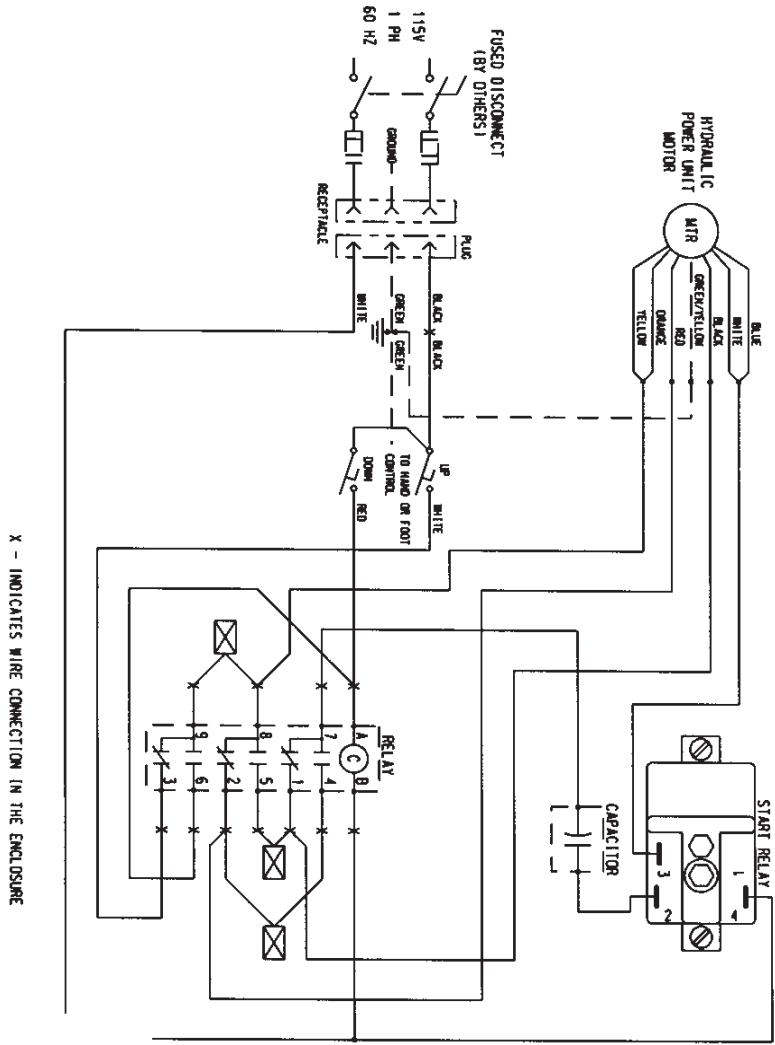

X - INDICATES WIRE CONNECTION IN THE ENCLOSURE

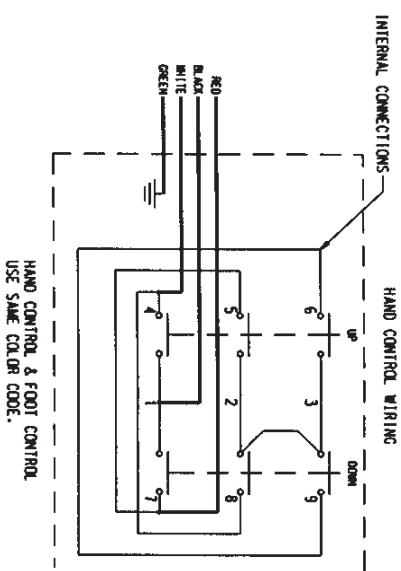
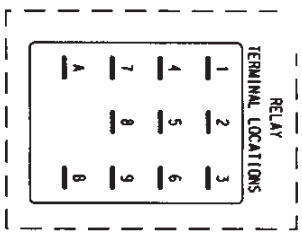
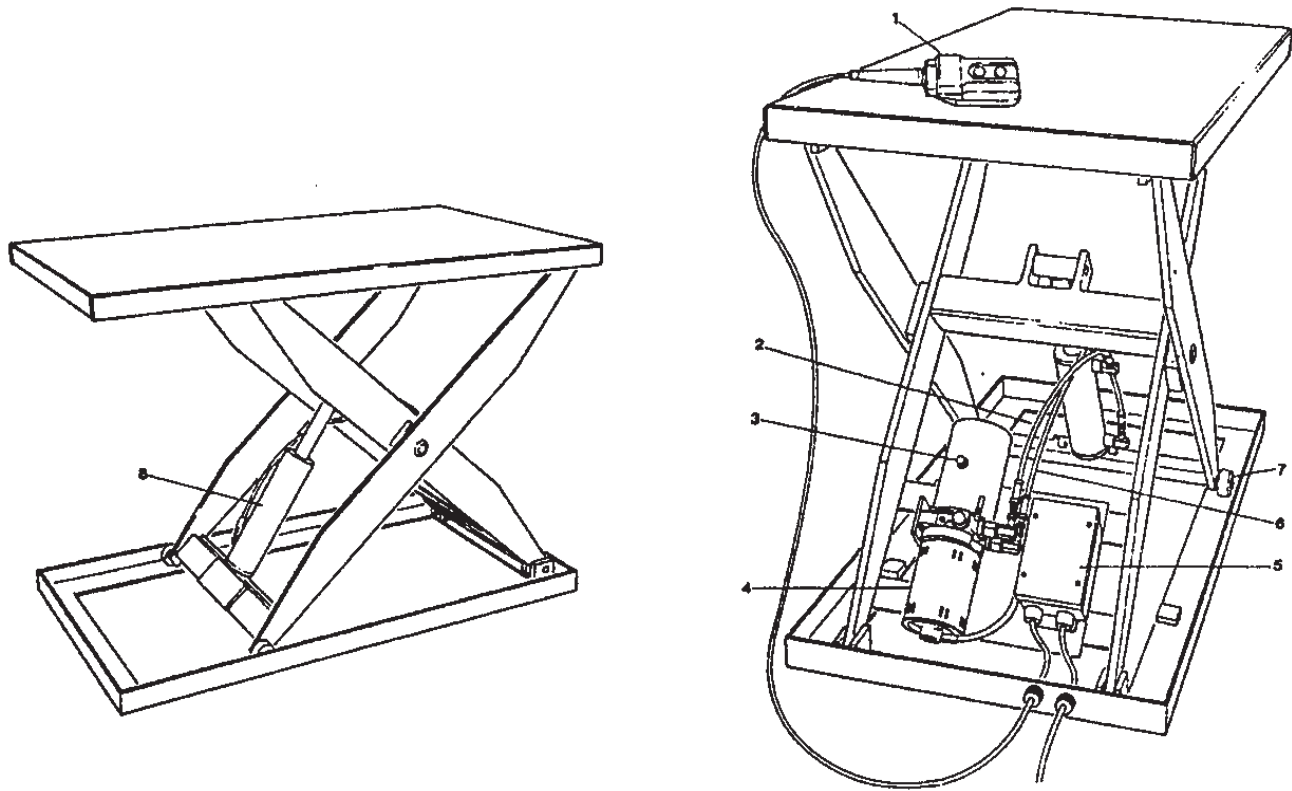

FIGURE 2: XS & WXS COMPONENTS DIAGRAM



Standard Replacement Parts (115/1/60 Power Only). For serial numbers beginning with "V" call Presto Lifts Parts Department for parts information.

DESCRIPTION	PART NUMBER	MODEL USED ON
CYLINDER	1001-171-03	XS24-10, XS24-15, WXS24-10, WXS24-15
	1001-171-04	XS36-10, XS36-15, WXS36-10, WXS36-15
AC/MOTOR, PUMP AND RESERVOIR	1001-092-01	XS24-15, WXS24-15
	1001-092-02	XS24-10, WXS24-15
	1001-092-11	XS36-15, WXS36-15
	1001-092-12	XS36-10, WXS36-110
CYLINDER SEAL KIT	1001-048	CYLINDER P/N 1001-171-03, 1001-171-04
ROLLER KIT	1000-067VR	ALL MODELS
HYDRAULIC HOSES (DOWN)	80000725VR	XS24-10, XS24-15, WXS24-10, WXS24-15
	80000122	XS36-10, XS36-15, WXS36-10, WXS36-15
HYDRAULIC HOSES (UP)	80000156	XS24-10, XS24-15, WXS24-10, WXS24-15
	1001-113-31.5VR	XS36-10, XS36-15, WXS36-10, WXS36-15
SAFETY VELOCITY FUSE	1000-086	ALL MODELS
START RELAY	E326	ALL MODELS
START CAPACITOR	E327	ALL MODELS
RELAY 3 PLE 2 THROW	E324	ALL MODELS
FOOTSWITCH	E308-E36	FOOT CONTROL MODELS ONLY
ELECTRICAL BOX	1001-145	ALL MODELS
HAND CONTROL	80000263	HAND CONTROL MODELS ONLY

SECTION 6

DXS Lifts

MODEL	LOW HGT	RAISED HGT	STANDARD PLATFORM	END/SIDE CAPACITY	MAX OVERSIZE PLATFORM	END/SIDE CAPACITY	
DXS24-10	5 1/4"	29"	24" X 36"	1000 LBS.	36" X 48"	760 LBS.	
DXS24-15	5 1/4"	29"	24" X 36"	1500 LBS.	36" X 48"	1140 LBS.	
DXS36-10	5 1/4"	41"	24" X 48"	1000 LBS.	36" X 60"	760 LBS.	
DXS36-15	5 1/4"	41"	24" X 48"	1500 LBS.	36" X 60"	1140 LBS.	
							* See note

* Capacity is based on the load center of gravity being within 12" of the lift center and equally distributed over 60% of the table

FIGURE 3: DXS COMPONENTS DIAGRAM

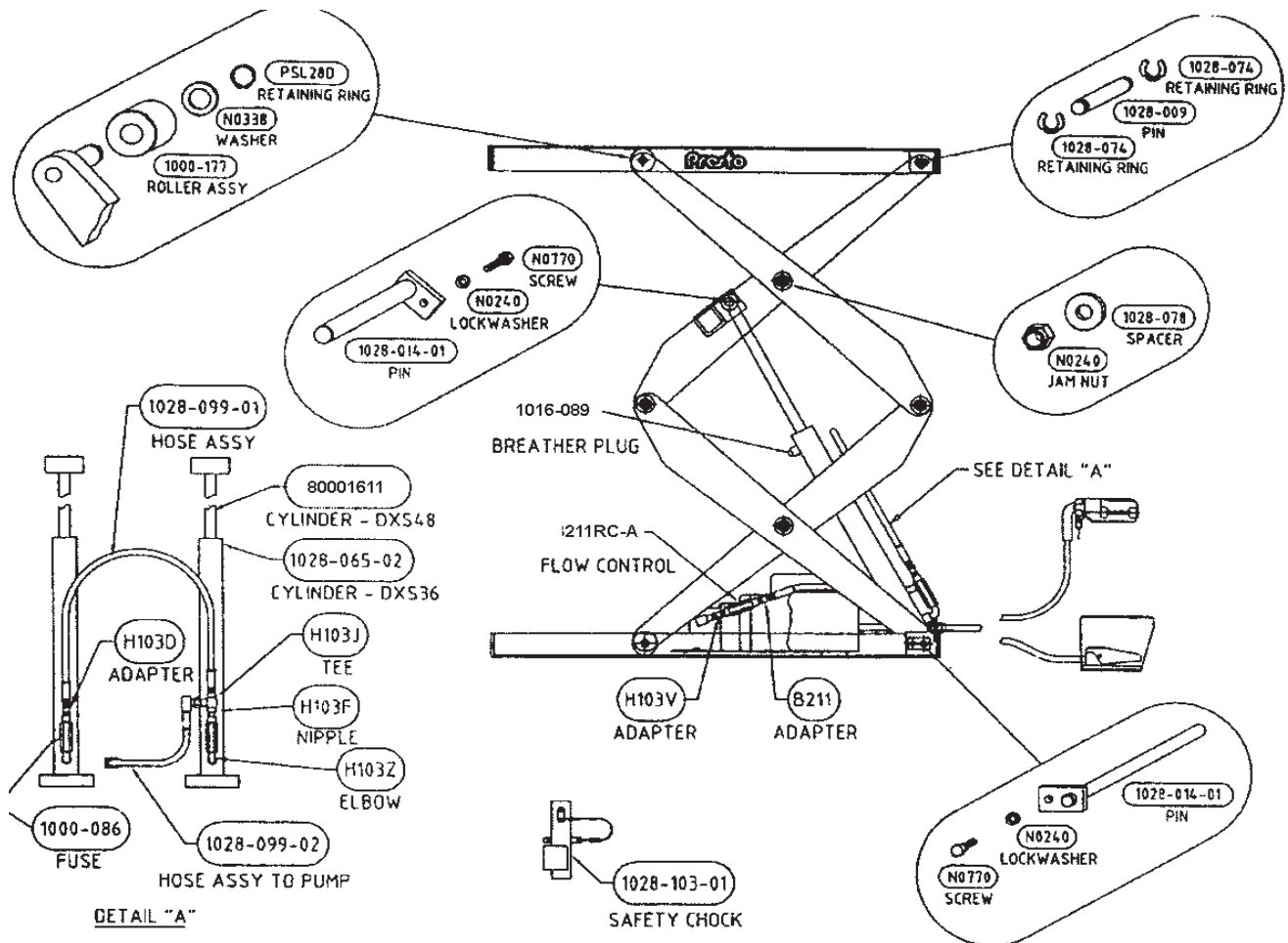

FIGURE 4: DXS POWER UNIT COMPONENTS

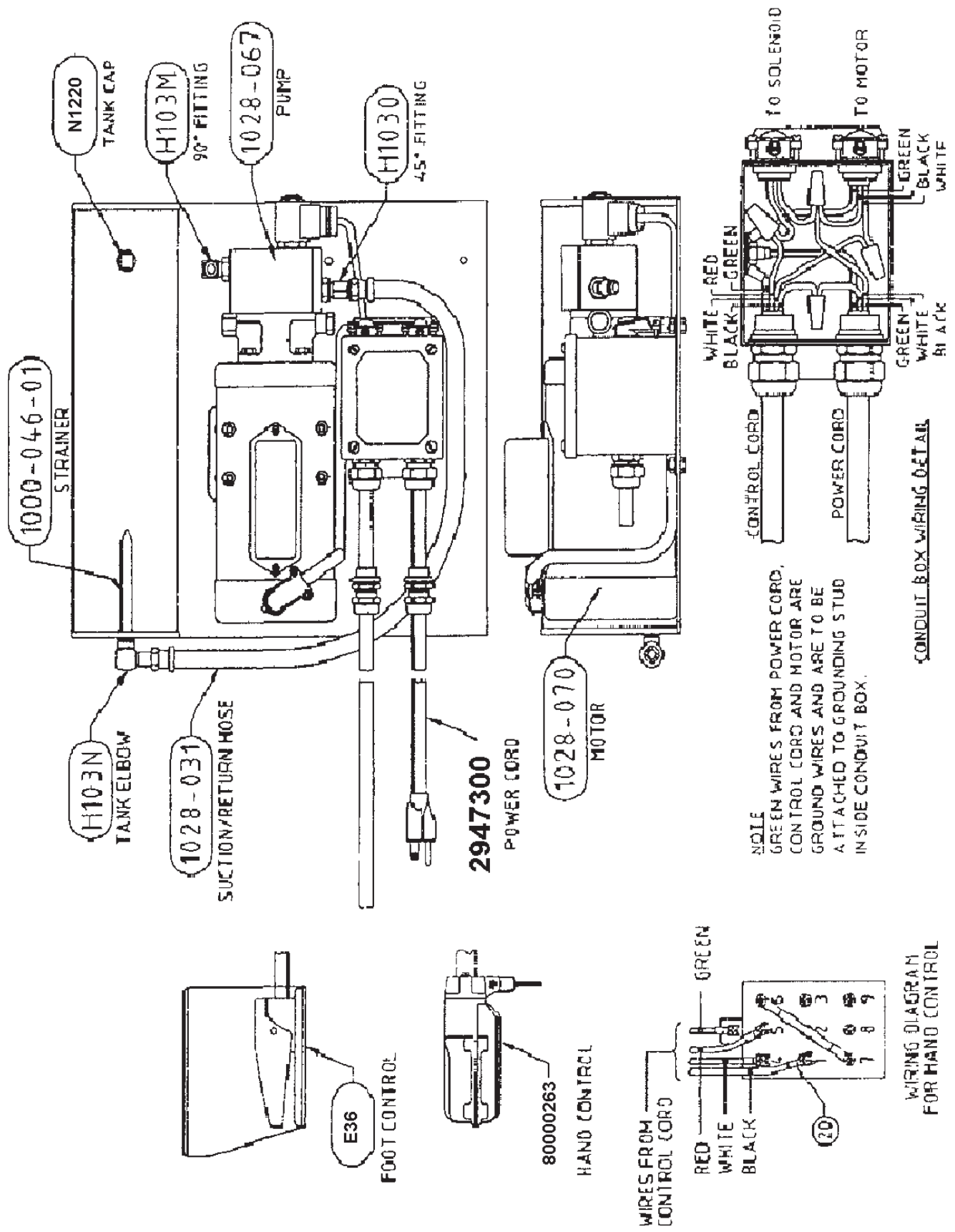

FIGURE 5: HYDRAULIC SCHEMATIC (ALL MODELS)

BI-DIRECTIONAL PUMPS

These pumps are driven by reversible motors and are primarily used to power double-acting cylinders in both directions. Locking checks that hold the load in either direction are standard.

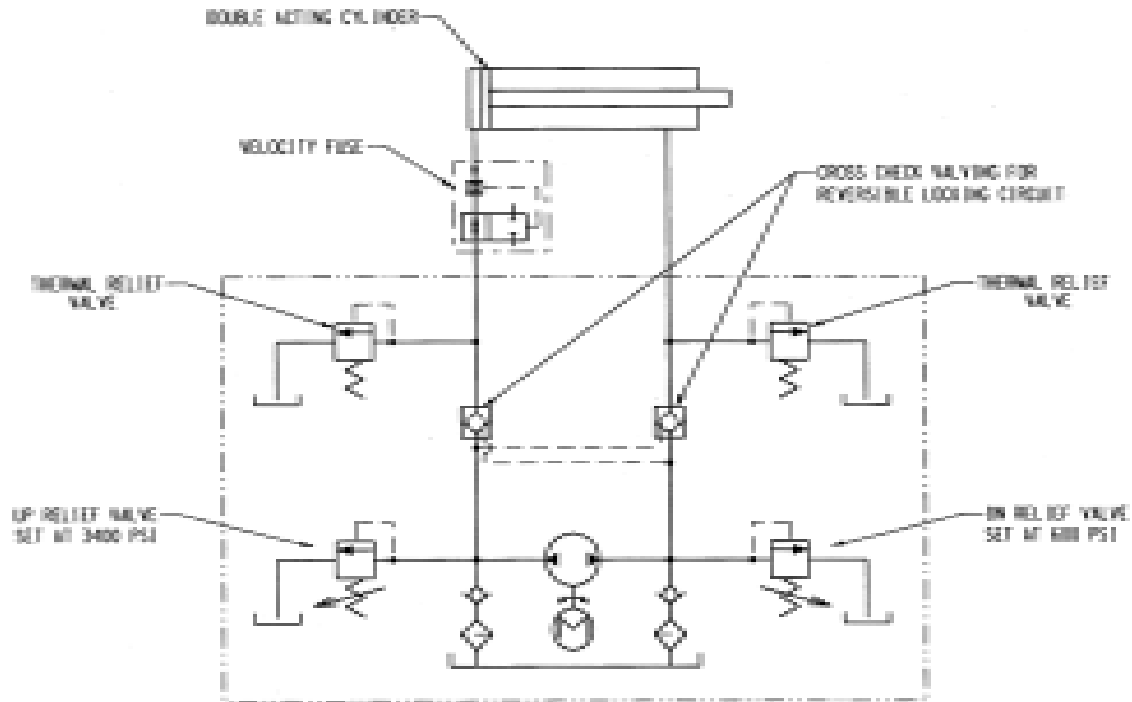

Table 2 – Hydraulic Oil Specifications

If the lift will be used at normal ambient temperatures, Presto Lifts supplies the unit with Conoco Super Hydraulic 32 oil. This may be replaced by any other good quality oil with 150 SSU at 100° F and rust and oxidation inhibitors and anti-wear properties.

If the lift will be used at ambient temperatures below 0°F, use aircraft grade hydraulic oil. Type 15 aircraft hydraulic oil is recommended.

The following are equivalent to Conoco Super Hydraulic 32:

TYPE	MANUFACTURER
AW32	CITGO
DTE 24	EXXON/MOBIL
NUTO H32	EXXON/MOBIL
AMOCO AW32	CHEVRON (AMOCO CO.)

CAUTION!

It is very important to keep the hydraulic oil free of dirt, dust, metal chips, water, and other contamination. Most of the problems with hydraulic systems are caused by contamination in the oil.

Ordering Replacement Parts

Presto Lifts has carefully chosen the components in your unit to be the best available for the purpose. Replacement parts should be identical to the original equipment. Presto Lifts will not be responsible for equipment failures resulting from the use of incorrect replacement parts or from unauthorized modifications to the unit.

Presto Lifts can supply all replacement parts for your lift. With your order, please include the model number and the serial number of the unit. You can find these numbers on the name plate. This plate is located within the scissors mechanism.

To order replacement parts, please call the Presto Parts Department. Parts are shipped subject to the following terms:

- FOB factory
- Returns only with the approval of our parts department.
- Credit cards preferred (except parts covered by warranty).
- Freight collect for truck (except parts covered by warranty).
- Freight – prepaid and invoice for small parcel shipments (except parts covered by warranty).

Parts replaced under warranty are on a “charge-credit” basis. We will invoice you when we ship the replacement part, then credit you when you return the worn or damaged part.

Presto Parts Department

21 Park Street
Attleboro, MA 02703

Telephone: 800-343-9322
FAX: 888-788-6496
Email: service@PrestoLifts.com

www.PrestoLifts.com

RESTOCKING POLICY

Presto Lift, Inc.'s goal is for you to be satisfied with your order. Merchandise may be returned, but returns will be subject to a restocking fee to cover the costs Presto Lift, Inc. incurs which include but are not limited to handling, storage of the units, etc. Presto Lift, Inc. will issue refurbishing costs where end-user wear is apparent. We would prefer to not charge for these costs but find it necessary any apologize for any inconvenience. Please review the RETURN MATERIALS AUTHORIZATION (RMA) PROCEDURES.

PARTS

Standard parts may be returned with a 20% restocking fee. Modified or custom-engineered parts are not returnable. Unfortunately, due to potentially concealed damage, all sales of electrical assemblies are final.

QUALITY ISSUES

Should you feel there is a quality problem, please contact the seller to ask questions and gather information on how to rectify the issue. Presto Lift Inc. reserves the right to determine potential credits, as a result of factory defects, based on its inspection of the merchandise.

GENERAL

All products shipped from our factory have passed Quality Assurance inspection and testing. The carrier of choice has signed for, and accepted the product in new working condition. The customer should inspect to ensure it is not received damaged, has no concealed damage or is not incomplete. Parts orders are determined to be complete based upon Presto Lift, Inc. inspection sheets and carrier shipping weights.

RETURN MATERIALS AUTHORIZATION (RMA) PROCEDURES

Although Presto Lift, Inc. is not legally obligated to issue a credit for any merchandise, the RETURN MATERIALS AUTHORIZATION (RMA) PROCEDURE is provided as a courtesy to our customers in the event they do not receive what they wanted.

If a customer wishes to return a Presto Lift, Inc. product, the first step in the process is to request an RMA number from Presto Lift, Inc.'s Customer Service Department. This request must be made on or before the thirtieth (30th) calendar day following the date of Presto Lift, Inc.'s invoice for the merchandise being returned.

The RMA number must appear on the outside of any packaging material for a return to be accepted and processed by Presto Lift, Inc. Customers shipping returns back to Presto Lift, Inc. from the Continental US, Canada and Mexico have fourteen (14) days from the effective date of the RMA to have the merchandise arrive freight prepaid at Presto Lift, Inc. Returns from locations other than the Continental US, Canada and Mexico must be shipped within the fourteen (14) day period to arrive Free On Board (FOB) at Presto Lift Inc as soon as practical. If a customer believes Presto Lift, Inc.'s merchandise is defective, freight will be reimbursed to the original "Bill To" on the invoice if Presto Lift Inc. finds that the merchandise is defective.

Please remember that merchandise with RMA's coming back to Presto Lift Inc. from the Continental US, Canada and Mexico will not be accepted by Presto Lift Inc. if the returned goods do not arrive freight prepaid at Presto Lift Inc. within the fourteen (14) day effective period.

All credits issued are less restocking fees as applicable, plus any assessed outbound/inbound in-transit damages.

Return addresses: please refer to your RMA for the address to which your product should be returned.

Presto Lift Inc.
715 Highway 77
Manila, Arkansas 72442

Telephone: 800-343-9322
Fax: 888-788-6496

Presto Lifts Limited Warranty Policy

Presto Lifts warrants all of its products against defects in the welded structural frame and, if applicable, scissor legs from faulty material and workmanship for a period of five (5) years from the date of invoice.

A lifetime limited warranty is provided for the Airstroke Actuator™ in all pneumatic lifts against any defect due to faulty material or workmanship.

All batteries are covered under a separate limited warranty from the battery manufacturer for a period of one year from the date of invoice.

All other components have a limited warranty against defects in faulty material and workmanship for a two (2) year period from the date of invoice and 30 day limited warranty on labor. Please note that prior authorization from Presto Lifts is required on all warranty work.

There are no implied warranties of any kind, more specifically, there are no warranties of merchantability or fitness for any particular purpose. Presto Lifts' sole warranty shall be as set forth in this limited warranty.

Presto Lifts will elect to repair or replace a defective component without charge, if any components should become defective within the limited warranty period. Proof of purchase is required for warranty. The charge for shipping the defective component is the responsibility of the buyer and must be accompanied with an RMA number. The shipping charge to return the component to the buyer is the responsibility of Presto Lifts, Inc.

This limited warranty does not cover labor expense for removal or reinstallation of components after thirty days. This limited warranty shall not cover, among other things: damages resulting from foreign matter or water, failure to provide reasonable and necessary maintenance, and if applicable, use of product while charger is plugged into an AC outlet, or failure to follow operating instructions. The limited warranty is not valid for damage resulting from negligence, accident, unreasonable use, abuse or misuse, exceeding data plate capacities or altering the product without Presto Lifts authorization.

Presto Lifts expressly disclaims and excludes any liability for consequential, incidental, indirect or punitive damages or financial loss to people or property resulting from any breach of warranty or the operation or failure of this product.

Presto Lifts makes no representation that this product complies with local, state, or federal safety/product standards codes. Should this product fail to comply in any way with those codes, it shall not be considered a defect of materials or workmanship. Presto Lifts shall not be held liable for any damages resulting from noncompliance. It is the dealer's responsibility to exercise this limited warranty. This limited warranty is provided to the original purchaser (defined as the original end user) and is nontransferable. This constitutes the complete and final agreement involving Presto Lifts and limited warranty obligations for products.