

# XP24-3 & XP24-6 Series Scissor Lifts

## Installation, Operation and Service Manual

Model Number \_\_\_\_\_

Serial # \_\_\_\_\_

Date placed in service \_\_\_\_\_

**IMPORTANT: READ CAREFULLY  
BEFORE INSTALLING OR OPERATING LIFT**

Part orders are subject to a \$50 minimum charge.



This manual was current at the time of printing. To obtain the latest, most updated version, please contact Presto Lifts Customer Service Department or go to our website: [www.PrestoLifts.com](http://www.PrestoLifts.com) -- you will find a complete list of current owner's manuals to print.

# CONTENTS

<b>SECTION 1: Introduction</b> .....	4
<b>SECTION 2: Safety</b> .....	4
<b>SECTION 3: Unpacking and Assembly</b> .....	5
A. Inspection.....	5
<b>SECTION 4: Operation</b> .....	5
A. Method Of Operation.....	5
<b>SECTION 5: Maintenance</b> .....	5
A. Routine Inspection and Maintenance .....	5
Table 1: Hydraulic Oil Specifications.....	6
<b>SECTION 6: Parts Breakdown</b> .....	7-8
ORDERING REPLACEMENT PARTS.....	9
RESTOCKING POLICY & RMA POLICY.....	10
RETURN GOODS AUTHORIZATION (RMA) PROCEDURES.....	11
WARRANTY.....	12
<b>LIST OF FIGURES:</b>	
Fig. 1 Foot pedal .....	5
Fig. 2 XP24 Assembly .....	7

## SECTION 1

# INTRODUCTION

This manual provides all the information for the safe and proper assembly, operation and maintenance of the Presto Lift Inc. Model XP24-3 and XP24-6 lifts. It is important that this manual be read by all personnel involved with the installation, maintenance or operation of the scissor lift. These models are designed for in-plant and non-hazardous locations.



## SECTION 2

# SAFETY

The safety of all persons installing, using, servicing, or working near the unit is of paramount concern to Presto Lifts. The lift is a powerful machine with moving parts, and is **capable of causing personal injury if proper precautions are not taken**. Therefore, throughout this manual, Presto Lifts has identified certain hazards, which may occur in the use of the unit, and provided appropriate **instructions** or precautions that should be taken to avoid these hazards. In some cases, Presto Lifts' has also pointed out the **consequences** that may occur if Presto Lifts' instructions or precautions are not followed. Presto Lifts uses the following nationally recognized system for identifying the severity of the hazards associated with its products:

**DANGER** – Immediate hazard that will result in severe personal injury or death.

**WARNING** – Hazard or unsafe practice that could result in severe personal injury or death.

**CAUTION** – hazard or unsafe practice that could result in minor personal injury or property damage.

**In the interest of safety, please read the entire manual carefully. You must understand the material in this manual before you install, use, or service the unit. If you have any question about any of the instructions in this manual, please contact Presto Lifts Inc. at 1-800-343-9322.**

**CAUTION!**

**Hazardous or unsafe practice will possibly result in personal injury or property damage.**

**CAUTION!**

- **Do not repair or work on unit without chocking lift in an upright position.**
- **Do not overload the lift (see nameplate for capacity).**
- **Do not put feet or hands under lift when operating.**
- **Do not stand, sit or climb on the lift while stationary or moving.**
- **Do not move lift when load is in an elevated position.**
- **Place load in the center and evenly distributed on the table.**

### **SECTION 3** **UNPACKING AND ASSEMBLY**

**A. INSPECTION:**

Upon receipt of the XP24-3 and XP24-6 Scissor lift, inspect the equipment completely to determine if there is any shipment damage and that the lift is complete. *Do not* use the lift if there appears to be any damage.

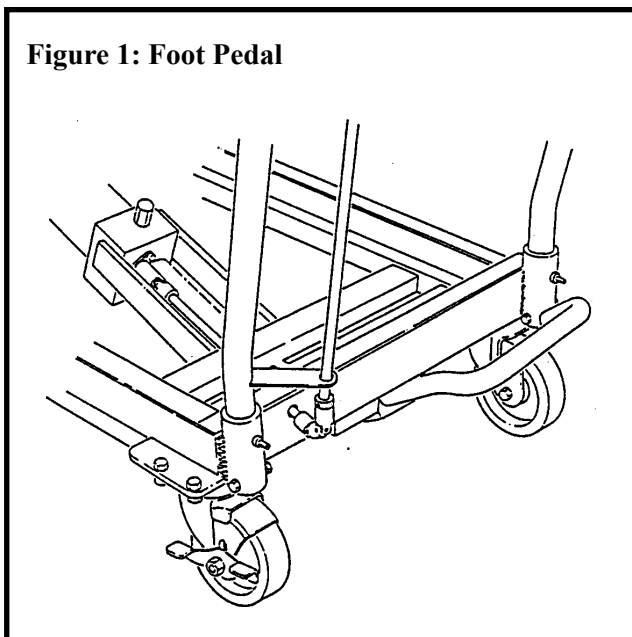

**Figure 1: Foot Pedal**

### **SECTION 4** **OPERATION**

**A. METHOD OF OPERATION:**

- To raise turn release knob clockwise till fully closed. Press on foot pedal to raise.
- To lower slowly turn release knob counter clockwise till the desired rate of decent is achieved.
- To lock lift in position press down on the wheel breaks located on the swivel casters at the push handle end.

### **SECTION 5** **MAINTENANCE**

Generally, the XP Series of scissor lifts require little maintenance. However, routine inspection and maintenance will minimize costly repairs or hazardous conditions.

**WARNING!**

**Never go under or service lift with a load on the table or with the scissor mechanism loaded. If possible, service the lift in a down position.**

**A. ROUTINE INSPECTION  
AND LOAD MAINTENANCE:**

All routine inspection maintenance should be performed on a monthly basis.

- Lubricate wheels and all pivot points of the unit with a medium weight oil or light grease.
- Check wheels for wear and replace if necessary.
- Check for leaks by looking for tell tale oil spots on the floor under the lift.
- Check oil level and fill if needed.

Recommended hydraulic oil: Super Hydraulic 32 Conoco

## Hydraulic Oil Specifications

If the lift will be used at normal ambient temperatures, Presto Lifts supplies the unit with Super Hydraulic 32 Conoco oil. This may be replaced by any other good quality oil with 150 SSU at 100° F and rust and oxidation inhibitors and anti-wear properties.

If the lift will be used at ambient temperatures below 0°F, use aircraft hydraulic oil. Use Type 15 aircraft hydraulic oil.

The following are equivalent to CONOCO SUPER HYDRAULIC 32:

<b>TYPE</b>	<b>MANUFACTURER</b>
AW32 .....	CITGO
DTE 24 .....	EXXON/MOBIL
NUTO H32 .....	EXXON/MOBIL
AMOCO AW32 .....	CHEVRON (AMOCO CO.)

### **CAUTION!**

**It is very important to keep the hydraulic oil free of dirt, dust, metal chips, water, and other contamination. Most of the problems with hydraulic systems are caused by contamination in the oil.**

**Part numbers are accurate for machines shipped prior to 2005. For machines shipped in 2005 or later, contact Presto Parts with the model and serial number.**

**Figure 2:  
XP24 ASSEMBLY  
300 and 600 LB**

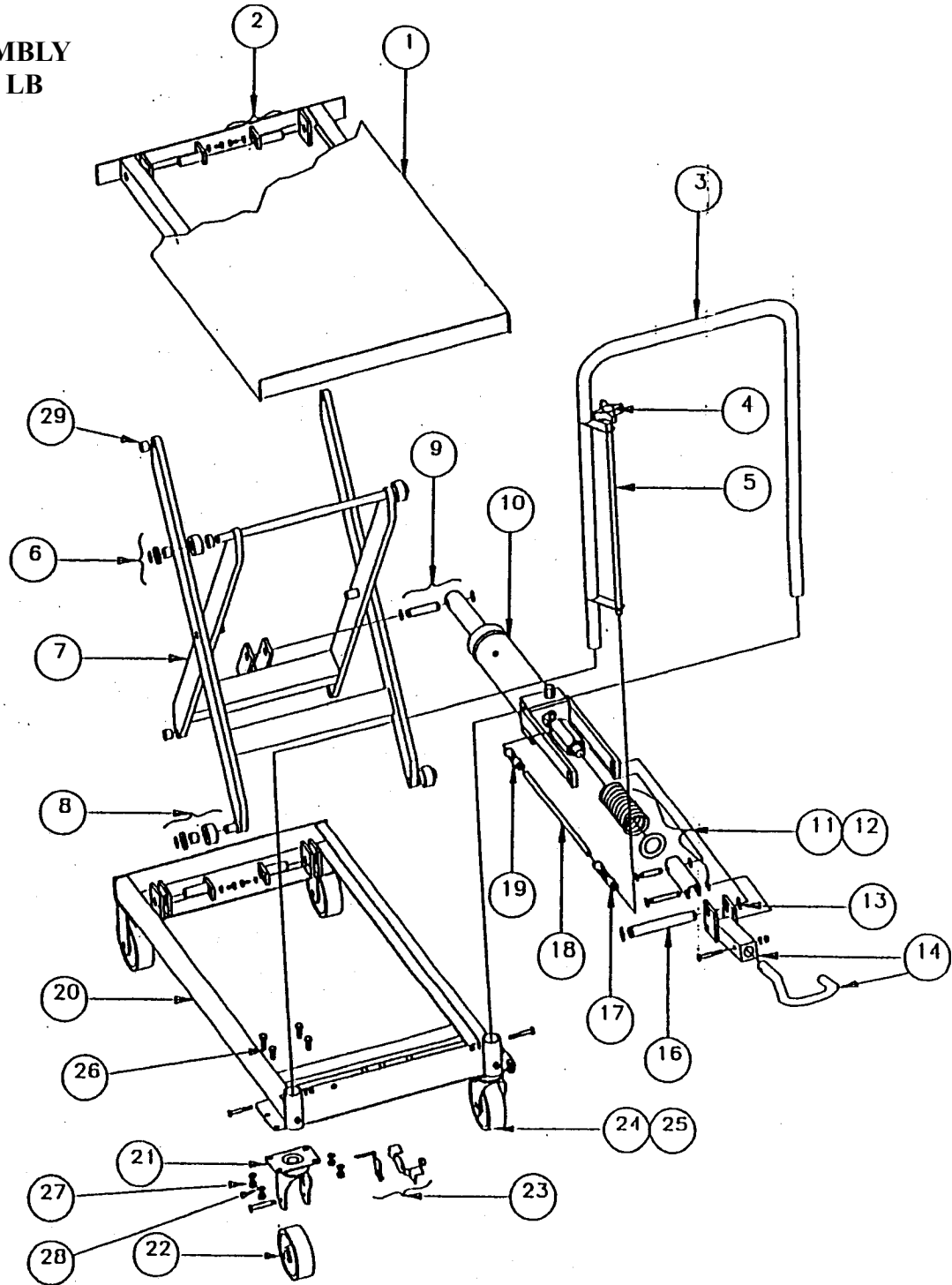

Item No.	Part No.	Description	Qty
1	1011-017	Top Assembly	1
2	1011-053	Pin Retainer Assembly	4
"	N0240	Lock Washer	4
"	N0765	20x 5/8 cap screw	4
3	1011-007	Handle Lift	1

**Part numbers are accurate for machines shipped prior to 2005. For machines shipped in 2005 or later, contact Presto Parts with the model and serial number.**

Item No.	Part No.	Description	Qty
4	1011-097	Release Knob	1
5	1011-090-02	Release Rod	1
6	1011-010	Roller	2
"	PSL28F	Retaining Ring	2
"	C108	Spacer	2
"	N0381	Washer	2
"	1000-32-08	Bushing 10DU08	2
7	1011-021	Legs Assembly	1
8	1011-010	Roller	2
"	PSL28F	Retaining Ring	2
"	N0381	Washer	2
"	1000-32-08	Bushing 10DU08	2
9	1011-044	Pin Pivot Ram	1
"	PSL28F	Retaining Ring	2
10	1011-102-300	XP24-300 Pump Assembly	1
"	1011-102-600	XP24-600 Pump Assembly	1
11	PSL28A	Retaining Ring	2
"	PSL28	Lever Pin 3/8 x 1 _	1
"	1011-031-02	Lever Pin 3/8 x 2 3/8	600lb
"	1011-028-01	Link/Plunger	1
"	1010-009-01	Spring	1
"	N0384	Washer	1
12	PSL28A	Retaining Ring	2
"	PSL28	Lever Pin 3/8 x 1 _	1
"	1011-031-02	Lever Pin 3/8 by 2 3/8	300 lb
"	1011-028-02	Link/Plunger	1
"	1010-009-05	Spring	1
"	N0380	Washer	1
13	PSL28G	Retaining Ring	2
14	1011-108	Foot Lever Assembly	1
"	1011-026	Plate Link	2
"	1011-107	Holder Foot Peddle w/lever	1
"	1011-027	Holder Foot Peddle	1
"	1011-052	Foot lever	1
16	1011-030	Pivot Pin _ x 5 3/16	1
17	1011-098	Double Universal joint	1
18	1011-090-01	Release Rod	1
19	1011-099	Single Universal Joint	1
20	1011-016	Base Assembly	1
21	1011-058-05	Caster/Swivel	2
22	1011-058-03	Caster/Swivel	4
23	1011-058-04	Brake Assembly	1
24	1011-058-01	Swivel Caster Without Brake	1
25	1011-058-02	Swivel Caster With Brake	1
26	N0817	5/16 – 18 x _ Lg Bolt	8
27	N0060	5/16 – 18 Nut	8
28	N00250	5/16 Lock Washer	8
29	1000-32-08	Bushing 10DU08	4

## Ordering Replacement Parts

Presto Lifts has carefully chosen the components in your unit to be the best available for the purpose. Replacement parts should be identical to the original equipment. Presto Lifts will not be responsible for equipment failures resulting from the use of incorrect replacement parts or from unauthorized modifications to the unit.

Presto Lifts can supply all replacement parts for your lift. With your order, please include the model number and the serial number of the unit. You can find these numbers on the name plate. This plate is located within the scissors mechanism.

To order replacement parts, please call the Presto Parts Department. Parts are shipped subject to the following terms:

- FOB factory
- Returns only with the approval of our parts department.
- Credit cards preferred (except parts covered by warranty).
- Freight collect for truck (except parts covered by warranty).
- Freight – prepaid and invoice for small parcel shipments (except parts covered by warranty).

Parts replaced under warranty are on a “charge-credit” basis. We will invoice you when we ship the replacement part, then credit you when you return the worn or damaged part.

### **Presto Parts Department**

21 Park Street  
Attleboro, MA 02703

Telephone: 800-343-9322

FAX: 888-788-6496

Email: [parts@PrestoLifts.com](mailto:parts@PrestoLifts.com)

**[www.PrestoLifts.com](http://www.PrestoLifts.com)**

## **PARTS**

Standard parts may be returned with a 20% restocking fee. Modified or custom-engineered parts are not returnable. Unfortunately, due to potentially concealed damage, all sales of electrical assemblies are final.

## **QUALITY ISSUES**

Should you feel there is a quality problem, please contact the seller to ask questions and gather information on how to rectify the issue. Presto Lift Inc. reserves the right to determine potential credits, as a result of factory defects, based on its inspection of the merchandise.

## **GENERAL**

All products shipped from our factory have passed Quality Assurance inspection and testing. The carrier of choice has signed for, and accepted the product in new working condition. The customer should inspect to ensure it is not received damaged, has no concealed damage or is not incomplete. Parts orders are determined to be complete based upon Presto Lift, Inc. inspection sheets and carrier shipping weights.

## **RETURN GOODS AUTHORIZATION POLICY**

Presto Lifts provides the Return Goods Authorization (RGA) Policy, for specific models, as a courtesy to our distributors in the event they do not receive what they ordered. If a customer wishes to return a Presto Lifts product, please contact the Customer Service Department and request an RGA number. This request must be made on or before the fifteenth calendar day following the date of Presto Lifts' invoice for the merchandise. Not all units are returnable. Quantity orders and special designs cannot be returned under any circumstances. Presto Customer Service reserves the right for final judgment on all product returns.

The RGA number must appear on the outside of any packaging material for a return to be accepted and processed by Presto Lifts. Customers shipping returns from the Continental US, Canada, or Mexico have thirty (30) days from date of RGA issue to have the product arrive at Presto Lifts' facility. All merchandise must arrive Free on Board at Presto Lifts' facility or the shipment will be refused and returned to the sender. All credits are issued less restocking and refurbishing charges, regardless if the merchandise was damaged in transit.

Return addresses: please refer to your RMA for the address to which your product should be returned.

Presto Lift Inc.  
715 Highway 77  
Manila, Arkansas 72442

Telephone: 800-343-9322  
Fax: 888-788-6496

# Presto Lifts Limited Warranty Policy

Presto Lifts warrants all of its products against defects in the welded structural frame and, if applicable, scissor legs from faulty material and workmanship for a period of five (5) years from the date of invoice.

All other components have a limited warranty against defects in faulty material and workmanship for a two (2) year period from the date of invoice and 30 day limited warranty on labor. Please note that prior authorization from Presto Lifts is required on all warranty work.

There are no implied warranties of any kind, more specifically, there are no warranties of merchantability or fitness for any particular purpose. Presto Lifts' sole warranty shall be as set forth in this limited warranty.

Presto Lifts will elect to repair or replace a defective component without charge, if any components should become defective within the limited warranty period. Proof of purchase is required for warranty. The charge for shipping the defective component is the responsibility of the buyer and must be accompanied with an RMA number. The shipping charge to return the component to the buyer is the responsibility of Presto Lifts, Inc.

This limited warranty does not cover labor expense for removal or reinstallation of components after thirty days. This limited warranty shall not cover, among other things: damages resulting from foreign matter or water, failure to provide reasonable and necessary maintenance, and if applicable, use of product while charger is plugged into an AC outlet, or failure to follow operating instructions. The limited warranty is not valid for damage resulting from negligence, accident, unreasonable use, abuse or misuse, exceeding data plate capacities or altering the product without Presto Lifts authorization.

Presto Lifts expressly disclaims and excludes any liability for consequential, incidental, indirect or punitive damages or financial loss to people or property resulting from any breach of warranty or the operation or failure of this product.

Presto Lifts makes no representation that this product complies with local, state, or federal safety/product standards codes. Should this product fail to comply in any way with those codes, it shall not be considered a defect of materials or workmanship. Presto Lifts shall not be held liable for any damages resulting from noncompliance. It is the dealer's responsibility to exercise this limited warranty. This limited warranty is provided to the original purchaser (defined as the original end user) and is nontransferable. This constitutes the complete and final agreement involving Presto Lifts and limited warranty obligations for products.

MANY NEEDS REQUIRE MANY OPTIONS...

**Presto** LIFTS



LET PRESTO MEET THOSE NEEDS!

Call Presto Sales  
for stock or  
customized lift inquiries:  
**800-343-9322**

Email: [sales@prestolifts.com](mailto:sales@prestolifts.com)

