

**Presto** LIFTS™  
worldwide material handling  
and ergonomic solutions

# P4 Level Loader

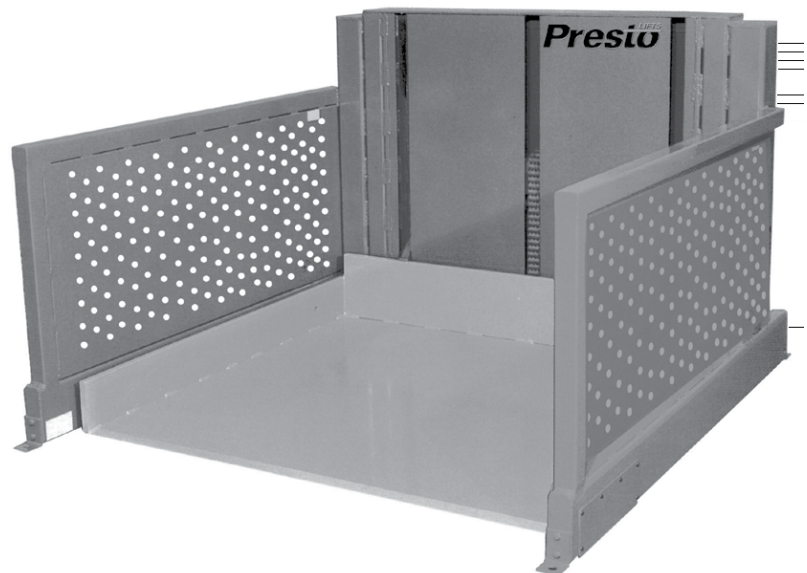

Model Number \_\_\_\_\_

Serial # \_\_\_\_\_

Date Placed in Service \_\_\_\_\_

**IMPORTANT: READ CAREFULLY  
BEFORE INSTALLING OR OPERATING LIFT**

Part orders are subject to a \$50 minimum charge



## The Presto Five Year Warranty

Presto Lifts, Inc. warrants all of its products against defects in the welded structural frame and, if applicable, scissor legs from faulty material and workmanship for a period of five years from the date of invoice. To read more about the warranty on this equipment, please turn to the back inside cover of this owners manual.

## INTRODUCTION

The P4 Level Loader is designed to allow faster, safer, and easier pallet loading and unloading. Pallets may be loaded or unloaded in a single step, using a fork truck, or hand pallet truck. Using a pushbutton or footswitch control, the operator can position boxes or containers at a convenient working height. This allows workers to load or unload without bending or stretching.

The unit includes a photo eye toe guard feature. A photo eye is positioned near the front of the unit. If the operator's toes block this photo eye, the unit stops immediately.

This manual contains instructions on the safe and proper installation, use, and maintenance of a P4 Level Loader. Please be sure that this manual is available to anyone who uses or services the P4 unit. Be sure that everyone who uses the P4 unit has read this manual.

**P4 Level Loaders may be used in a wide variety of industrial settings. The instructions included in this manual are not necessarily all-inclusive, because Presto Lifts cannot anticipate all conceivable or unique situations.**

**In the interest of safety, please read this whole manual carefully. Please understand the material in the manual before you install, use, or service the P4 unit. If you have any questions about the instructions in this manual, please contact your dealer or Presto Lifts Inc.**

Presto Lift's product warranty is shown on the rear cover of this manual. This instruction manual is **not intended to be or to create any other warranty, express or implied, including any implied warranty of merchantability or fitness for a particular purpose, all of which are hereby expressly excluded.** As set forth more specifically in the product warranty, Presto Lift's obligation under that warranty is **limited** to the repair or replacement of defective components, which shall be the buyer's **sole remedy**, and Presto Lift shall not be liable for any loss, injury, or damage to persons or property, nor for any direct, indirect, or consequential damage of any kind resulting from the P4 Level Loader.

# TABLE OF CONTENTS

INTRODUCTION .....	2
SAFETY .....	4
INSTALLATION INSTRUCTIONS .....	4
Preparation .....	4
Positioning the Unit.....	4
Electrical Connections .....	5
Testing .....	6
OPERATING INSTRUCTIONS.....	7
Safety Instructions .....	7
Loading the Unit.....	8
Raising the Platform .....	8
Lowering the Platform.....	9
MAINTENANCE AND TROUBLESHOOTING .....	10
Hazards .....	10
Routine Periodic Maintenance.....	11
Troubleshooting Check List .....	12
Repacking the Cylinder.....	15
Adjusting the Chain Tension .....	15
Ordering Replacement Parts .....	16

## LIST OF FIGURES

Fig. 1	Safety labels .....	5
Fig. 2	Pinch points .....	6
Fig. 3	Load the unit correctly .....	7
Fig. 4.	Electrical diagram .....	8
Fig. 5.	Hydraulic diagram.....	9
Fig. 6.	Parts identification — Front view .....	12
Fig. 7.	Parts identification — Rear view.....	13
Fig. 8.	Hydraulic pump.....	13
Fig. 9	Hydraulic oil specifications Table .....	16

## SAFETY

The safety of all persons installing, using, servicing, or working near the P4 Level Loader unit is of paramount concern to Presto. The P4 Level Loader unit is a powerful machine with moving parts, and is CAPABLE OF CAUSING PERSONAL INJURY IF PROPER PRECAUTIONS ARE NOT TAKEN.

Therefore, throughout this manual, Presto has identified certain hazards which may occur in the use of the P4 Level Loader unit, and provided appropriate INSTRUCTIONS or PRECAUTIONS which should be taken to avoid these hazards. In some cases, Presto has also pointed out the CONSEQUENCES which may occur if Presto's instructions or precautions are not followed. Presto uses the following system of identifying the severity of the hazards associated with its products:

PLEASE READ AND FOLLOW THIS INSTRUCTION MANUAL, INCLUDING ALL SAFETY INSTRUCTIONS AND PRECAUTIONS, CAREFULLY AND COMPLETELY.

**DANGER:** Immediate hazard which will result in severe personal injury or death.

**WARNING:** Hazard or unsafe practice which could result in severe personal injury or death.

**CAUTION:** Hazard or unsafe practice which could result in minor personal injury or property damage.

---

## INSTALLATION INSTRUCTIONS

### Preparation

1. Before you start to install the unit, check for local codes and ordinances which may apply. It is your responsibility to obtain any necessary permits.
2. Read all of these installation instructions carefully. Be sure to read and understand all of the warnings.
3. The unit should be placed indoors, or protected from the weather.

#### **WARNING!**

**Protect the unit from rain or moisture. If the electrical parts in the power unit get wet, workers may be hurt by electrical shock. The electrical parts may fail if they are wet.**

#### **WARNING!**

**The electric motor can create sparks. Don't install the unit in an area where flammable gases may be present.**

4. You will need these tools to install the unit:

- A crane or lift truck that can lift the unit safely. If you plan to lag the unit in place, you will need these tools:
- Shims and lag bolts.
- A masonry drill and bit to drill the holes for the lag bolts.
- Wrenches to fit the lag bolts
- Grouting material to fill any spaces under the frame of the machine.

### Positioning the Unit

1. Remove the shipping material. Unbolt the lag screws at the lag angles on the corners. (If you plan to bolt the unit in place, leave the lag angles attached to the frame of the unit. Otherwise, unbolt and remove the lag angles.)
2. On the front of this manual, write down the model number, serial number, and date the unit is placed in service. You can find the model number and serial number on the name plate.
3. During shipping, the platform of the unit is raised 5-1/2", and this platform is supported on two pins. This allows a space under the platform. When you want to move the

unit, put a pallet jack under the platform and lift the unit. This is the best way of moving the unit.

**CAUTION!**

**Always raise the platform and insert the pins before you move the unit. If you try to move the unit in another way, the frame may be bent. Be sure to remove the pins before you operate the unit. If you do not do this, the unit may be damaged. Once the unit has power, raise the platform just a bit to take the load off of the pins, then remove the pins.**

4. The unit has an 10' power cord. Choose a location where the cord can reach an outlet easily, without stretching the cord tightly.
5. Move the unit into position, supporting the platform of the unit. Place the unit on a firm, level surface.

**CAUTION!**

**If you place the unit on a surface which is not firm or level, the unit may**

**shift as it operates. You may be hurt, or the unit or load may be damaged.**

6. The unit may be operated without bolting the frame to the floor. However, the mounting arrangement is more secure if you use lag screws. Bolt the unit to the floor using four lag bolts. These should run through the lag angles at the corners of the base frame. Insert and tighten the lag bolts to secure the unit. Grout under the base rails to prevent vibration and distortion of the base frame.

**Electrical Connections**

**DANGER!**

**The unit uses a power supply of 115 volts AC. This voltage can kill you. Don't work with the electrical parts unless you are a qualified electrician.**

1. The unit is supplied with a power cord which is 10' long. You must provide a two-prong outlet within this distance from the unit. The circuit should be

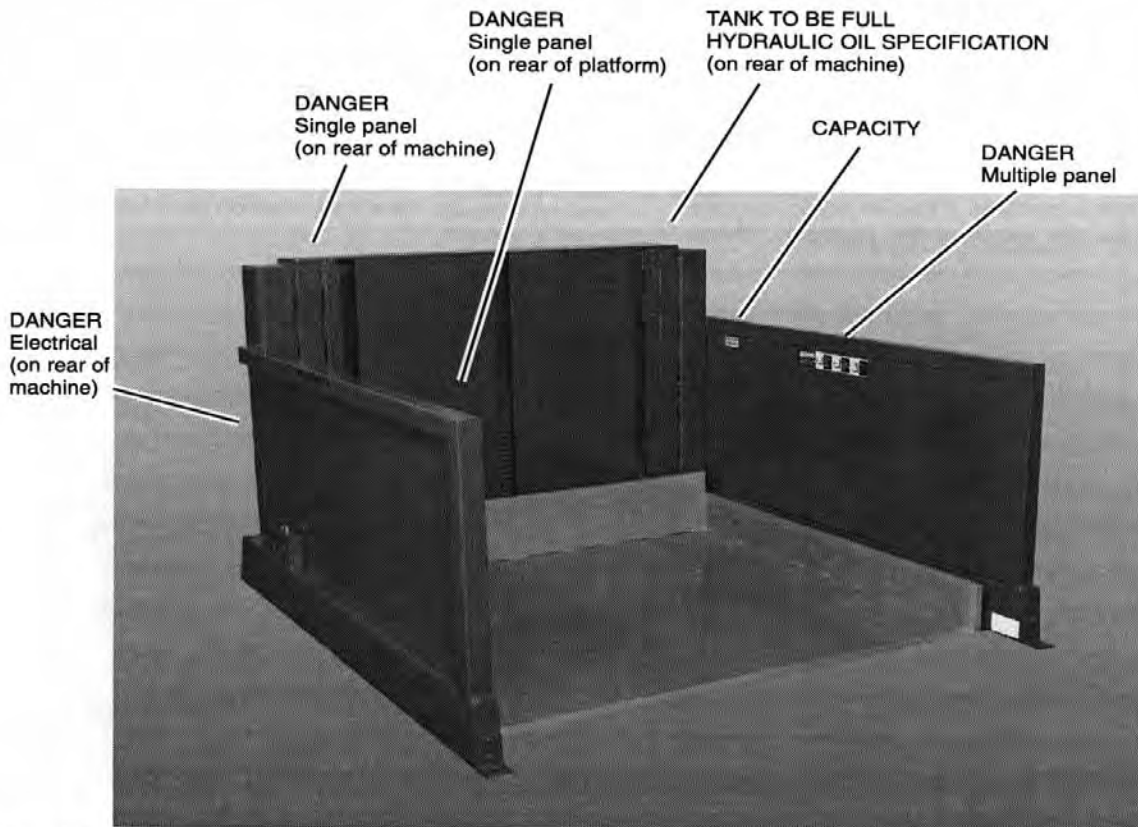

Fig. 1 Safety Labels

provided with a 20 amp circuit breaker or fuse.

### **WARNING!**

**To avoid fire danger, be sure to provide a circuit breaker or fuse.**

2. The standard unit has a foot switch assembly. Position the control box in a convenient location near the unit.
3. Check the level of the hydraulic fluid in the tank. In order to check the level, lower the unit completely and unplug the power cord. Remove the rear cover on the unit. When the unit is fully lowered, the oil should be 1/2" to 3/4" (13 to 19 mm) below the top of the tank. Add oil as necessary.

### **Testing**

1. Clear the area around the unit. Remove any loose wires, lumber, or other materials which might get in the way of the unit as it raises or lowers.
2. Warn others to stay away from the unit. Operate the unit through its full range of travel. The unit should rise smoothly with a quiet humming sound, and lower smoothly and quietly. Raise and lower the unit a few times to check the lifting action.

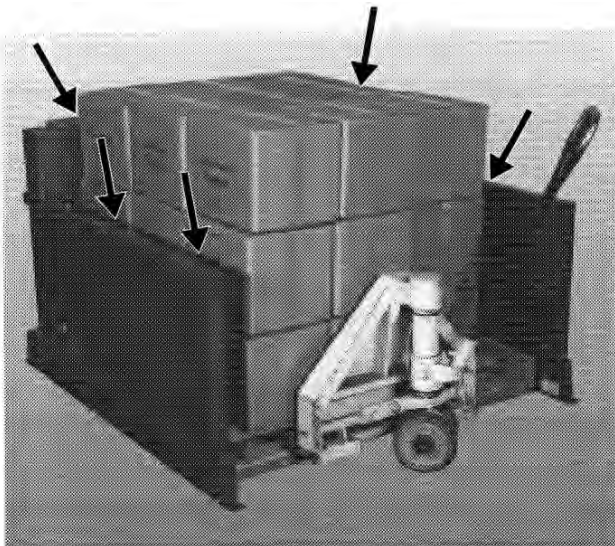

Fig. 2a Pinch points when loading

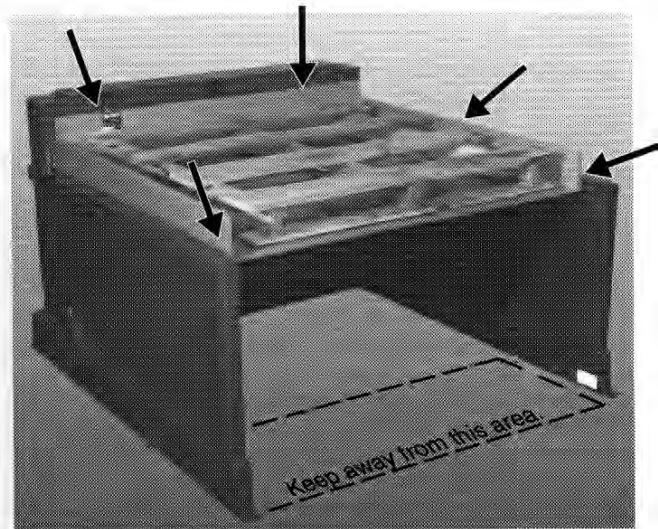

Fig. 2b Pinch points when raising or lowering

### **WARNING!**

**As the platform moves up and down, "pinch points" are created at the places shown in Fig. 2. If you are standing too close to the unit when it is moving, your arm or leg may be caught in the moving parts, and you may be hurt. Stay away from the pinch points when the unit is moving.**

3. Test the unit with the rated load. If the unit does not rise, and you hear a loud squealing noise, the pressure relief valve is operating. Contact Presto Lifts for instructions.

### **WARNING!**

**Don't continue to use the unit if this happens - the pump will overheat very quickly, and may be permanently damaged. Do not try to adjust the relief valve. If you change the setting on the relief valve, you may overwork the unit. This can cause the unit to fail suddenly, and you may be hurt.**

4. Clean up any spilled hydraulic fluid. Spilled hydraulic

oil is slippery, and may present a fire hazard. If you clean up any spilled fluid, you will be able to tell right away if the unit begins to leak.

5. Figure 1 shows the safety labels on this unit. Check to be sure all of the labels are in place.

## OPERATING INSTRUCTIONS

### Safety Instructions

#### **DANGER!**

The unit uses a power supply of 115 Volts AC. This voltage can kill you. **DON'T WORK WITH THE ELECTRICAL PARTS UNLESS YOU ARE A QUALIFIED ELECTRICIAN!**

#### **WARNING!**

As you operate this lift, follow these rules:

- Do not put your hands or feet under

the lift platform.

- Do not work under the lift platform without installing the safety pins. (See Fig. 6 and the section on "Maintenance.")

- Do not stand, sit, or ride on the lift.

#### **WARNING!**

This unit includes a photo eye toe guard. See Fig. 6. If something blocks the light beam, the unit will stop quickly. The control system will stop the motor and close the down valve, preventing the platform of the unit from moving down. This is designed to prevent the unit from lowering onto the operator's toes. If this safety system is not working correctly, do not operate the unit. Call a maintenance worker right away.

If the load is uneven, place the heavy section near the rear of the platform.

Always try to place the center of the load over the center of the platform (24" from the rear of the platform)

Do not place the heavy part of the load on the front of the platform.

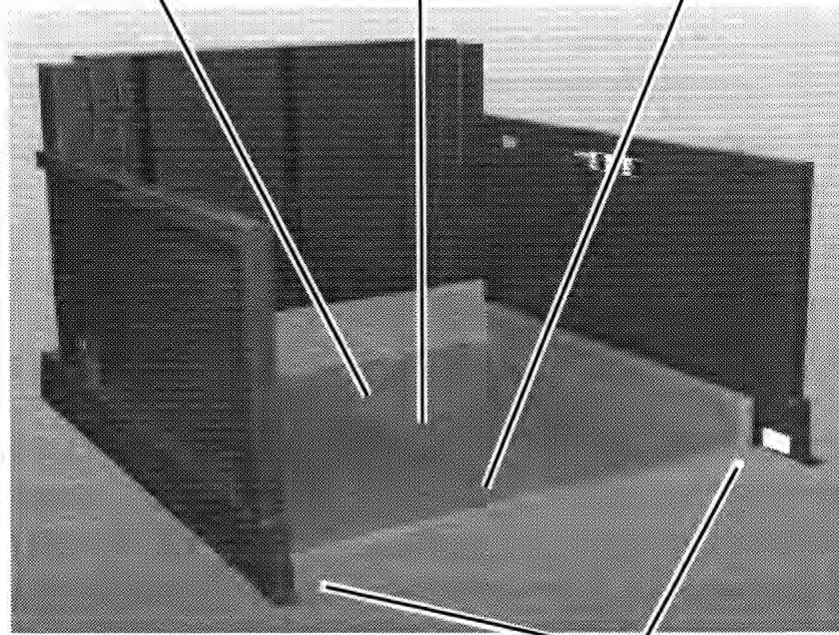

Balance the load side-to-side

**Fig. 3** Load the unit correctly

## Loading the Unit

1. Before operating the unit, please read and understand all of this section.
2. Be sure that the load weighs no more than the maximum rated for the unit. The maximum rated load is listed on the data plate. Remember that an empty pallet may weigh 40 lbs (18 kg) or more.
3. The load should always be balanced in the side-to-side direction. Whenever possible, place the load in the center of the pallet, as shown in Fig. 3. If the load is off-center on the pallet, place the heaviest part of the load near the back of the platform - never near the front!

### WARNING!

- Don't try to lift a load that exceeds the maximum rating. If you do not follow these rules, the unit may fail suddenly. Someone may be hurt, or the unit and load may be damaged.

- The unit is designed so it can lift the rated load if the load center is placed

over the center of the platform. (The load center should be 24" or 61 cm from the rear of the platform.) If the load is placed "offcenter," near the front of the platform, the unit will not be able to lift the rated load safely. It is also important that the load be centered side-to-side. For these reasons, it is very important to be sure the load is centered in the platform area.

4. Sometimes the unit may be used to lift parts which can roll. Stack the parts on the pallet so they cannot roll. Be sure that all parts of the load are secure, and will not move as the unit is operated.

## Raising the Platform

1. Before raising the platform, be sure all workers are clear of the unit.

### WARNING!

As the platform moves up and down, "pinch points" are created as shown

PHOTO EYE WIRE CONNECTION TABLE

PART NO.	MANUFACTURER'S PART NO.	WIRE A COLOR	WIRE B COLOR	WIRE C COLOR	NOTES
2800002	CG PA18CLR30T0	BROWN	<del>BROWN</del>	BLUE	2-WIRE DEVICE
10008610	MS CP18L2	BLUE	BROWN	BLACK	3-WIRE DEVICE
2122962	OPCON 14102R6513	BROWN	BLUE	BLACK	3-WIRE DEVICE
2122982	CH 1415ORL14	BROWN/GRAY	BLUE	BLACK	RELAY REQUIRED

#### NOTES:

1. WHEN AN UP LIMIT SWITCH IS PRESENT REMOVE THE JUMPER BETWEEN TERMINALS 3 & 3A AND WIRE UP LIMIT SWITCH TO THESE TERMINALS AS SHOWN.
2. THE LIFT WILL NOT EITHER RAISE OR LOWER WHILE THE TOEGUARD PHOTO EYE IS OBSTRUCTED.

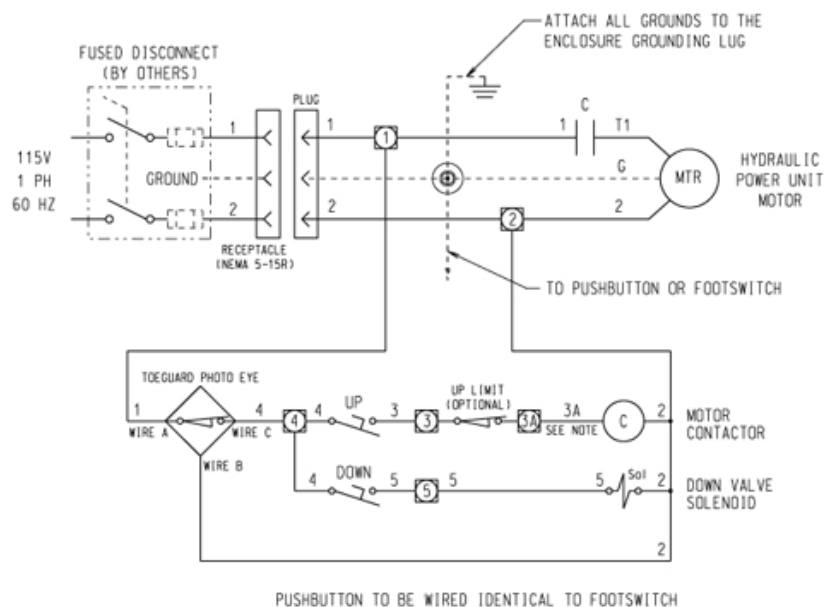

Fig. 4 Electrical diagram

in Fig. 2. **STAY AWAY FROM THESE PINCH POINTS!** Part of your body or clothing may become caught, and you may be hurt. Do not put your hands or feet under the platform. Do not stand or sit on the platform.

2. Before lifting, be sure the pallet is pushed up against the back of the unit. Be sure the fork lift or pallet truck is clear of the unit before you begin lifting.
3. Plug in the electrical cord. Be sure the cord cannot become caught in the moving parts as the platform rises.
4. Operate the unit. Press and hold the Up button to raise the platform, and Down to lower it. If the unit does not operate right away, unplug the power cord and call a qualified maintenance worker.

**WARNING!**

**If you hear a squealing noise from the pump, the pressure relief valve is operating. DON'T CONTINUE TO USE THE UNIT! The pump will overheat**

very quickly, and may be permanently damaged. The relief valve is included to protect the machine operators - **DO NOT CHANGE THE SETTING ON THE RELIEF VALVE.** If you do change the setting, this may cause a hydraulic part to fail. The platform may drop suddenly. Someone may be hurt, and the unit and load may be damaged. The hydraulic parts in the unit are designed to handle a certain amount of pressure. The relief valve has been included for the protection of all of the workers who use the unit.

**Lowering the Platform**

1. Press the Down button to lower the platform.
2. Before lowering the platform, be sure all workers are clear of the unit.

**WARNING!**

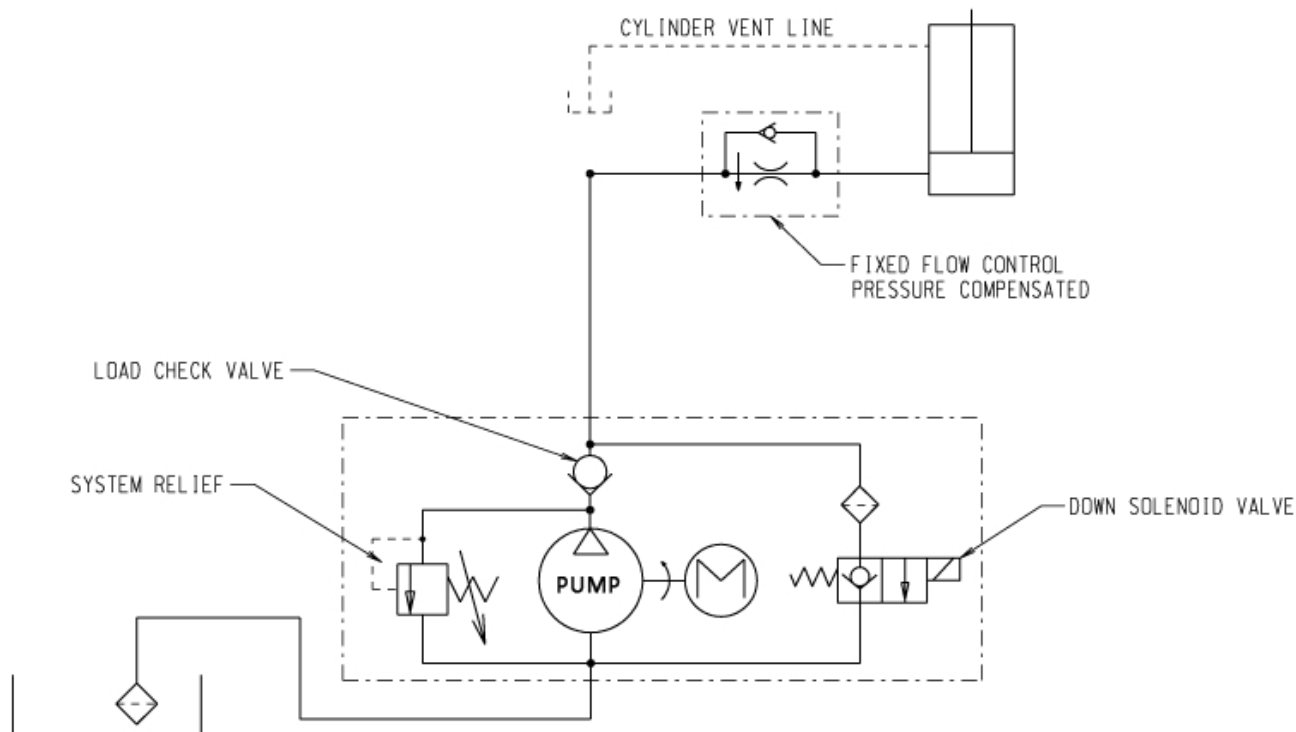

**Fig. 5 Hydraulic diagram**

**As the platform moves up and down, “pinch points” are created as shown in Fig. 2. STAY AWAY FROM THESE PINCH POINTS! Part of your body or clothing may become caught, and you may be hurt.**

3. There is a photoelectric toe guard near the front of this unit. If anything blocks the photoelectric beam, the unit will stop. This is designed to prevent an operator from lowering the platform onto his or her feet.

**WARNING!**

**Stand back from the unit when raising or lowering the platform. Keep your feet away from the platform when the unit is operating.**

## **MAINTENANCE AND TROUBLESHOOTING**

All servicing should be done by qualified personnel. Qualified personnel should be able to read and understand wiring and hydraulic diagrams. They should be able to troubleshoot live electrical circuits safely and in accordance with accepted practice. FOR SAFETY'S SAKE, if in doubt, please contact your distributor or Presto Lift's Customer Service Department at (800) 343-9322. Before servicing the unit, please read and understand all of this section and the section entitled "Operating Instructions."

### **Hazards**

There are several hazards you should be aware of as you service the unit:

**DANGER!**

**The unit uses a power supply of 115 Volts AC. This voltage can kill you. DON'T WORK ON THE ELECTRICAL PARTS UNLESS YOU ARE A QUALIFIED ELECTRICIAN!**

**WARNINGS!**

- **As the unit moves up and down, “pinch points” are formed as shown in Fig. 2. KEEP HANDS, FEET AND LOOSE CLOTHING AWAY FROM**

**THESE PINCH POINTS. If your hand or arm or a part of your clothing is caught, you may be hurt.**

- **Before performing any maintenance on the unit, lower the platform completely. Failure to do so could result in severe personal injury.**

- **You should not have to do any maintenance work with the platform raised. All normal maintenance can be done with the platform lowered. However, if you ever need to work under the platform, you must be careful to do this safely. Raise the platform until you can insert the safety pins on each side. The pins are shown in Fig. 6. Finally, unplug the power cord. DO NOT WORK UNDER THE PLATFORM UNTIL YOU HAVE INSERTED THE PINS. If you fail to do this, the platform may drop suddenly. You may be hurt.**

- **The relief valve has been included for the protection of all of the workers who use the unit. DON'T CHANGE THE RELIEF SETTING! If the relief valve does not open when it should, the unit may fail. Someone may be hurt, and the unit and load may be damaged.**

- **If the hydraulic fluid is released under high pressure, it can cause personal injury. Before you open any part of the hydraulic system, BE SURE TO RELEASE THE HYDRAULIC PRESSURE. You can do this by lowering the platform all the way down.**

- **The warning labels have been included for the safety of the operator. If the labels are worn or missing, or have been painted over, REPLACE THEM before releasing the lift for operation. Fig. 1 shows the safety**

## markings on this unit.

### Routine Periodic Maintenance

*Every month:*

- Remove the plate on the rear of the unit and check the mechanical parts. Inspect the leaf-type chain which lifts the platform. Check for signs of wear. If the machine is operated in a very dusty environment, you may have to wipe off the dust.
- Check the bolts which anchor the ends of the chain. The chain should be tight, and each bolt should be locked in place.
- Check the level and appearance of the hydraulic fluid. In order to check the level, lower the unit completely and unplug the power cord. Remove the rear cover on the unit. Remove the red plastic vent plug on top of the hydraulic tank, and use a dipstick to check the oil level. When the platform is fully lowered, the oil should be about 1/2" to 3/4" inch below the top of the tank. Add oil if necessary. Change the oil if it has darkened, or feels gritty or sticky.

### CAUTION!

**It is important to use hydraulic fluid with the correct grade and properties. See the hydraulic oil specification in Fig. 10 of this manual.**

*Every six months or 500 hours of operation, whichever comes first:*

- Lubricate the lifting chain lightly with spray lube or SAE 30 mineral oil.
- Lubricate the bushing inside the sheave or pulley which supports the upper part of the chain.
- Apply a light coat of grease to the vertical guides for the rollers on the rear of the unit.
- Check all of the hydraulic fittings and hoses, and tighten the connections if necessary. Sometimes the fittings can be worked loose by the vibrations from the power unit.

### WARNING!

**If a hydraulic fitting becomes loose,**

**or if a hydraulic hose breaks, the hydraulic fluid may escape from the system under pressure. If the platform is raised when this happens, it can drop quickly. Someone may be hurt, or the unit or load may be damaged. To avoid this problem, inspect all of the hydraulic hoses and fittings regularly, and replace them if they are worn or damaged.**

- The clear plastic vent line and the cylinder rod should be free of hydraulic fluid. If you find much fluid in either place, the cylinder seals may be leaking. (It is also possible the tank may be over-filled.) If the worn parts must be replaced, see the section on "Repacking the Cylinder."
- Lower the platform and disassemble the down valve as shown in Fig. 8. Blow the valve plunger clean with compressed air. Reassemble the valve and reinstall it.
- Drain and discard the hydraulic fluid. The suction filter is in the tank, at the point where the suction line runs out to the pump. Unscrew the hydraulic line, then remove the filter. Blow the filter clean with compressed air. Reinstall the filter in the tank and reassemble the hydraulic line.
- Refill the tank with new hydraulic fluid.

### CAUTION!

**If you continue to use fluid after it has "worn out," the moving parts in the system will wear more quickly.**

- Be sure all of the warning labels are in position and legible. See Fig. 1. THE WARNING LABELS ARE INTENDED TO PROTECT YOUR WORKERS. If the labels are missing, or if they have been painted over, replace them.

## Troubleshooting Check List

All servicing should be done by qualified personnel. Qualified personnel should be able to read and understand wiring and hydraulic diagrams. They should be able to troubleshoot live electrical circuits safely and in accordance with accepted practice. FOR SAFETY'S SAKE, if in doubt, please contact your distributor or Presto Lifts at (800) 343-9322.

Before servicing the unit, read and understand this entire section and the section entitled "Operating Instructions."

### WARNING!

**Before performing any maintenance on this unit, lower the platform completely.**

*If the platform will not raise:*

### CAUTION!

**If the platform will not raise, do not continue to hold the Up button for more than 2 or 3 seconds. You may**

**damage the pump.**

1. The sensor and reflector are mounted at the front of the unit, near the floor level. There may be something blocking the beam of the photo eye toe guard. The reflector may need to be cleaned or replaced.
2. The load may be too heavy. Check the actual weight of the load. The rated capacity of the unit is shown on the name plate.

### WARNING!

**DON'T CHANGE THE SETTING OF THE RELIEF VALVE. If you do change the setting, this may cause a hydraulic part to fail. The platform may drop suddenly. Someone may be hurt, and the unit and load may be damaged. The hydraulic parts in the lift are designed to handle a certain amount of pressure. The relief valve is set to relieve this pressure before it becomes too great. The relief valve has been included for the protection**

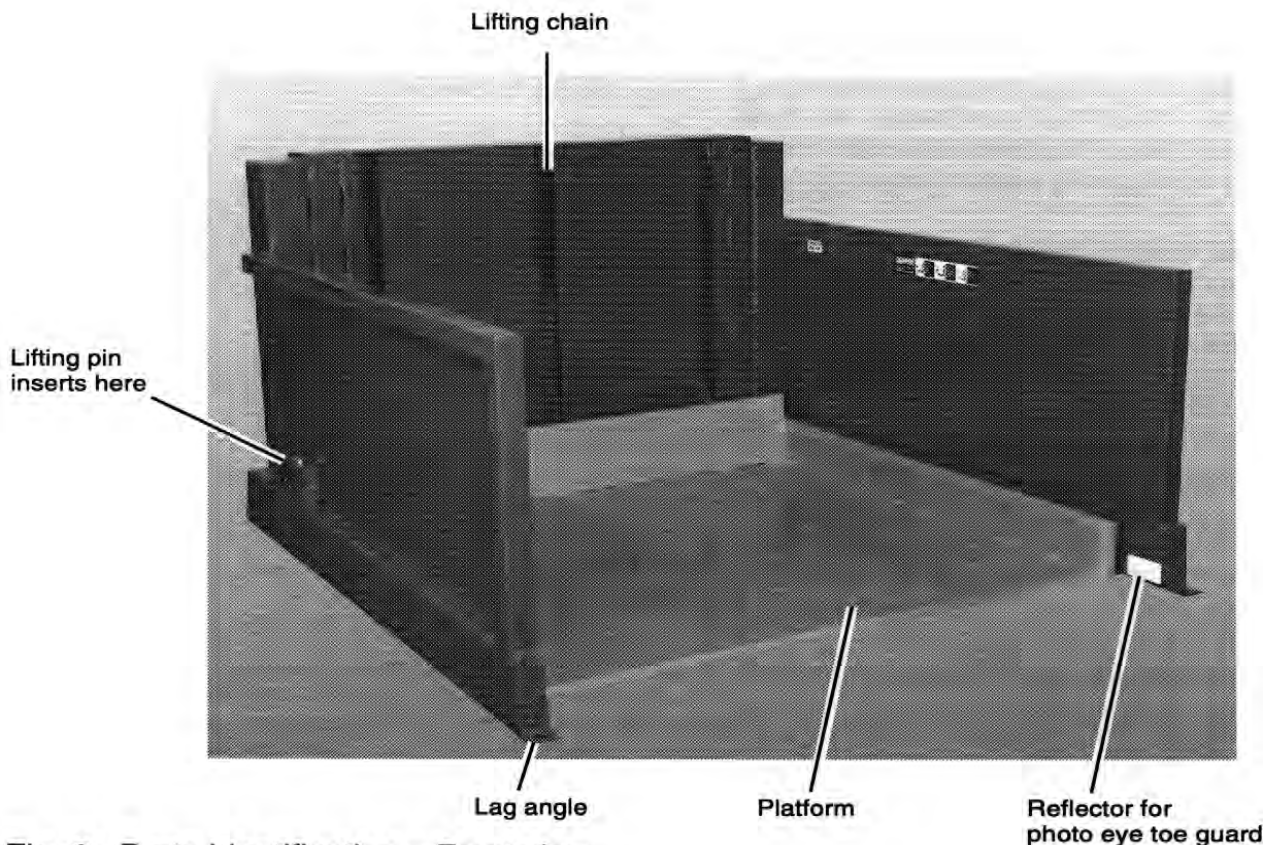

**Fig. 6 Parts identification – Front view**

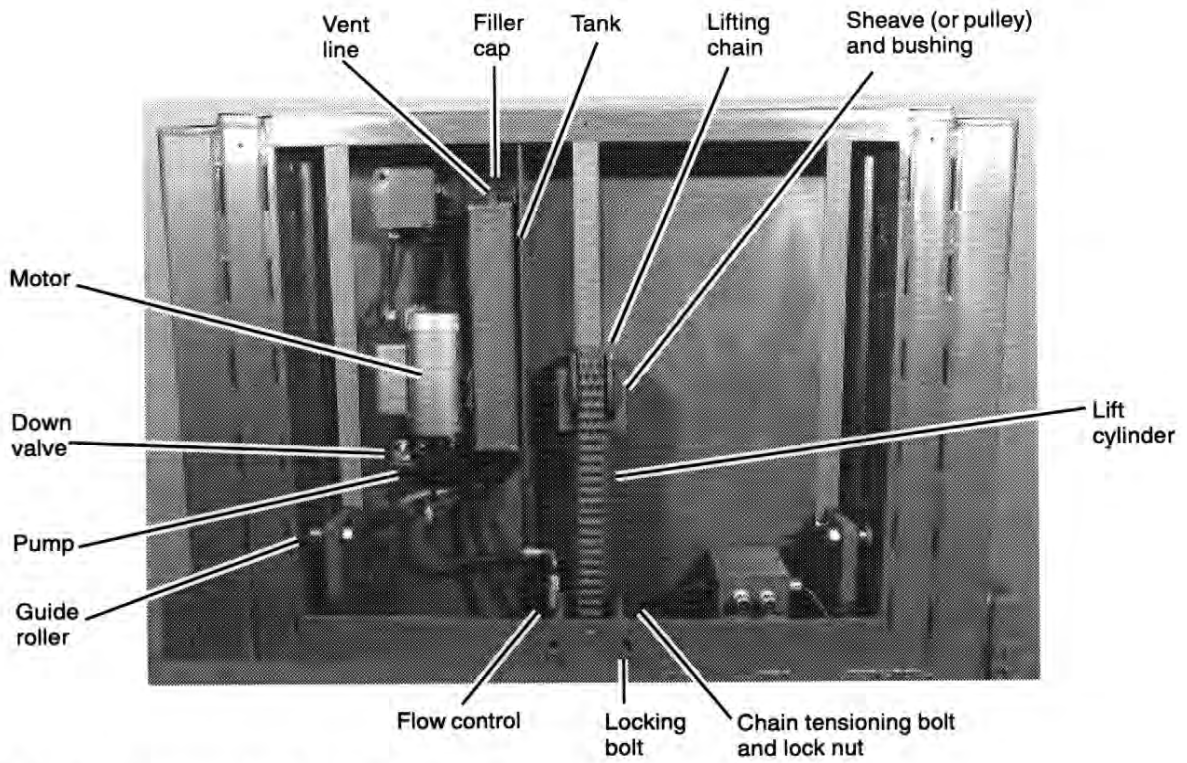

**Fig. 7 Parts identification – Rear view**

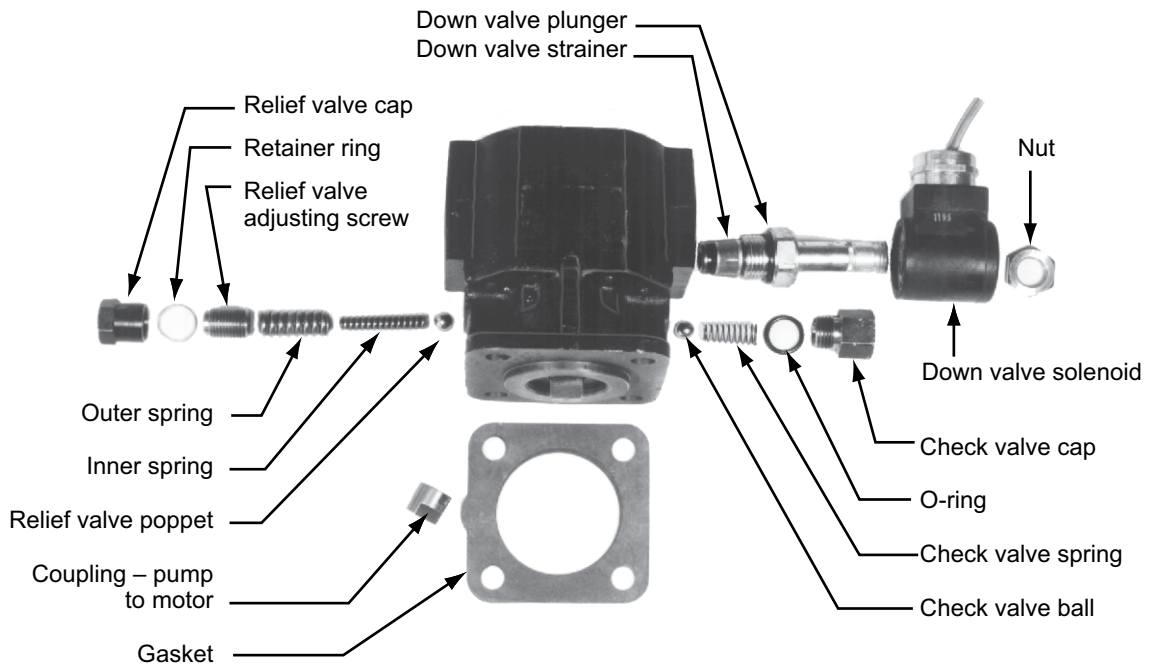

**Fig. 8 Pump**

**of all of the workers who use the unit.**

3. If the motor is not running, check the electrical plug, the circuit breaker or fuse, and the wiring to the motor.
4. The hydraulic oil level may be low. In order to check the level, lower the unit completely and unplug the power cord. Remove the rear cover on the unit. When the platform is lowered as far as possible, the oil should be about 1/2" to 3/4" inch below the top of the tank. Remove the red plastic plug on top of the tank. Use a dipstick to check the oil level.
5. The motor voltage may be too low. Check the voltage at the starter when the motor is under load. The supply voltage should be within  $\pm 10\%$  of the rating.
6. The tank vent may be plugged. Before operating the unit, you must remove the solid plug from the top of the tank and insert the red plastic vented plug. The vent line must be clear.
7. The suction filter may be clogged. Clean the suction filter as described in the section on "Periodic Maintenance."
8. A vacuum leak may be allowing air into the suction line, causing cavitation (loss of suction) in the pump. Check all fittings in the suction line, and tighten or replace them if necessary.

**CAUTION!**

**If cavitation is allowed to continue, the pump may be damaged, and may have to be replaced.**

9. For the platform to raise, the down valve must be de-energized and closed completely. Check for a problem with the wiring to the down valve. Check the solenoid in the valve with a voltmeter. The valve must be clean and free to operate. To check this, remove the solenoid and then the valve. Look for dirt or metal chips which could block the valve action. Clean the valve plunger with kerosene, then blow it clean with compressed air. The expansion nut which holds the solenoid should be finger tight only).

10. If the pump has been changed, the coupling may not have been installed between the motor and pump. See the pump assembly in Fig. 8.

***If the platform elevates, but fails to hold a load:***

1. The check valve may be leaking. Dirt on the valve seat can prevent the valve from closing fully. The check valve is mounted in the base of the pump housing, as shown in Fig. 8. Remove the check valve cap and inspect the valve for dirt or metal chips which may be preventing it from closing. You may be able to restore the seal by lightly rapping the ball into the seat using a 1/4" diameter rod and a small hammer.
2. The down valve may be energized. While the unit is holding a load, the down valve should be de-energized and fully closed. Check the solenoid in the valve with a voltmeter. The valve must be clean and free to operate. To check this, remove the solenoid and then the valve. Look for dirt or metal chips which could block the valve action. Clean the valve plunger with kerosene, then blow it clean with compressed air. The expansion nut which holds the solenoid should be finger tight only!
3. The cylinder may be leaking. Look for oil on the cylinder rod and in the vent line. (This may also occur if the oil tank has been over-filled.) If you find much oil in either place, and the tank is not over-filled, the cylinder must be repacked. See the section in this manual on "Repacking the Cylinder."

***If the platform fails to lower:***

1. The sensor and reflector for the photo eye toe guard are mounted at the front of the unit, near the floor level. There may be something blocking the beam of the photo eye. The reflector may need to be cleaned or replaced.

2. The down valve may be de-energized. While the platform is lowering, the down valve should be energized and fully open. Check the solenoid in the valve with a voltmeter. The valve must be clean and free to operate. Remove the solenoid, then the down valve. Look for dirt or metal chips which could block the valve action. Clean the valve plunger with kerosene, then blow it clean with compressed air. Before reassembly, depress the plunger manually several times to be sure it moves freely. The expansion nut which holds the solenoid should be finger tight only! If these steps do not solve the problem, please call the Presto Lifts Customer Service Department at (800) 343-9322.

### Repacking the Cylinder

The lift in the P4 Level Loader unit may use several different types of cylinders. To order a repacking kit and receive repacking instructions, please call the Presto Lifts Parts Department at (800) 343-9322. When ordering, specify the model number and serial number of the unit.

### Adjusting the Chain Tension

It is very important that the lifting chain be tensioned correctly. As the chain is used, it will tend to stretch a bit. Over time, this can cause it to loosen. The adjustment mechanism is located on the rear of the unit. See Fig. 7.

1. Lower the platform completely and unplug the unit. Remove the plate on the rear of the unit.
2. Loosen the two locking bolts.
3. Find the two tensioning bolts. Loosen the locknuts so you can turn these bolts.
4. Turn the tensioning bolts in or out to change the chain tension. The chain tension should be as tight as possible without lifting the platform off of the floor. The setting should be the same on each side of the mechanism.
5. When the tension is correct, tighten the lock nuts.
6. Tighten the two locking bolts.

# Ordering Replacement Parts

Presto Lifts has carefully chosen the components in your unit to be the best available for the purpose. Replacement parts should be identical to the original equipment. Presto Lifts will not be responsible for equipment failures resulting from the use of incorrect replacement parts or from unauthorized modifications to the unit.

Presto Lifts can supply all replacement parts for your lift. With your order, please include the model number and the serial number of the unit. You can find these numbers on the name plate. This plate is located on the lower corner of the right side panel.

To order replacement parts, please call the Presto Parts Department. Parts are shipped subject to the following terms:

- FOB factory
- Returns only with the approval of our parts department.
- Credit cards preferred (except parts covered by warranty).
- Freight collect for truck (except parts covered by warranty).
- Freight – prepaid and invoice for small parcel shipments (except parts covered by warranty).

Parts replaced under warranty are on a “charge-credit” basis. We will invoice you when we ship the replacement part, then credit you when you return the worn or damaged part.

## Presto Parts Department

21 Park Street  
Attleboro, MA 02703  
Telephone: 800-343-9322  
FAX: 888-788-6496  
Email: [service@PrestoLifts.com](mailto:service@PrestoLifts.com)  
**[www.PrestoLifts.com](http://www.PrestoLifts.com)**

### Table 9 – Hydraulic Oil Specifications

If the lift will be used at normal ambient temperatures, Presto Lifts supplies the unit with Conoco Super Hydraulic 32 oil. This may be replaced by any other good quality oil with 150 SSU at 100° F and rust and oxidation inhibitors and anti-wear properties.

If the lift will be used at ambient temperatures below 0°F, use aircraft hydraulic oil. Use Type 15 aircraft hydraulic oil.

The following are equivalent to CONOCO SUPER HYDRAULIC 32:

<b>TYPE</b>	<b>MANUFACTURER</b>
AW32 .....	CITGO
DTE 24 .....	EXXON/MOBIL
NUTO H32 .....	EXXON/MOBIL
AMOCO AW32 .....	CHEVRON (AMOCO CO.)

### **CAUTION!**

**It is very important to keep the hydraulic oil free of dirt, dust, metal chips, water, and other contamination. Most of the problems with hydraulic systems are caused by contamination in the oil.**

## **PARTS**

Standard parts may be returned with a 20% restocking fee. Modified or custom-engineered parts are not returnable. Unfortunately, due to potentially concealed damage, all sales of electrical assemblies are final.

## **QUALITY ISSUES**

Should you feel there is a quality problem, please contact the seller to ask questions and gather information on how to rectify the issue. Presto Lift Inc. reserves the right to determine potential credits, as a result of factory defects, based on its inspection of the merchandise.

## **GENERAL**

All products shipped from our factory have passed Quality Assurance inspection and testing. The carrier of choice has signed for, and accepted the product in new working condition. The customer should inspect to ensure it is not received damaged, has no concealed damage or is not incomplete. Parts orders are determined to be complete based upon Presto Lift, Inc. inspection sheets and carrier shipping weights.

## **RETURN GOODS AUTHORIZATION POLICY**

Presto Lifts provides the Return Goods Authorization (RGA) Policy, for specific models, as a courtesy to our distributors in the event they do not receive what they ordered. If a customer wishes to return a Presto Lifts product, please contact the Customer Service Department and request an RGA number. This request must be made on or before the fifteenth calendar day following the date of Presto Lifts' invoice for the merchandise. Not all units are returnable. Quantity orders and special designs cannot be returned under any circumstances. Presto Customer Service reserves the right for final judgment on all product returns.

The RGA number must appear on the outside of any packaging material for a return to be accepted and processed by Presto Lifts. Customers shipping returns from the Continental US, Canada, or Mexico have thirty (30) days from date of RGA issue to have the product arrive at Presto Lifts' facility. All merchandise must arrive Free on Board at Presto Lifts' facility or the shipment will be refused and returned to the sender. All credits are issued less restocking and refurbishing charges, regardless if the merchandise was damaged in transit.

Return addresses: please refer to your RMA for the address to which your product should be returned.

Presto Lift Inc.  
715 Highway 77  
Manila, Arkansas 72442

Telephone: 800-343-9322  
Fax: 888-788-6496

# Presto Lifts Limited Warranty Policy

Presto Lifts warrants all of its products against defects in the welded structural frame and, if applicable, scissor legs from faulty material and workmanship for a period of five (5) years from the date of invoice.

All other components have a limited warranty against defects in faulty material and workmanship for a two (2) year period from the date of invoice and 30 day limited warranty on labor. Please note that prior authorization from Presto Lifts is required on all warranty work.

There are no implied warranties of any kind, more specifically, there are no warranties of merchantability or fitness for any particular purpose. Presto Lifts' sole warranty shall be as set forth in this limited warranty.

Presto Lifts will elect to repair or replace a defective component without charge, if any components should become defective within the limited warranty period. Proof of purchase is required for warranty. The charge for shipping the defective component is the responsibility of the buyer and must be accompanied with an RMA number. The shipping charge to return the component to the buyer is the responsibility of Presto Lifts, Inc.

This limited warranty does not cover labor expense for removal or reinstallation of components after thirty days. This limited warranty shall not cover, among other things: damages resulting from foreign matter or water, failure to provide reasonable and necessary maintenance, and if applicable, use of product while charger is plugged into an AC outlet, or failure to follow operating instructions. The limited warranty is not valid for damage resulting from negligence, accident, unreasonable use, abuse or misuse, exceeding data plate capacities or altering the product without Presto Lifts authorization.

Presto Lifts expressly disclaims and excludes any liability for consequential, incidental, indirect or punitive damages or financial loss to people or property resulting from any breach of warranty or the operation or failure of this product.

Presto Lifts makes no representation that this product complies with local, state, or federal safety/product standards codes. Should this product fail to comply in any way with those codes, it shall not be considered a defect of materials or workmanship. Presto Lifts shall not be held liable for any damages resulting from noncompliance. It is the dealer's responsibility to exercise this limited warranty. This limited warranty is provided to the original purchaser (defined as the original end user) and is nontransferable. This constitutes the complete and final agreement involving Presto Lifts and limited warranty obligations for products.

MANY NEEDS REQUIRE MANY OPTIONS...

**Presto** LIFTS



LET PRESTO MEET THOSE NEEDS!

Call Presto Sales  
for stock or  
customized lift inquiries:  
**800-343-9322**

Email: [sales@prestolifts.com](mailto:sales@prestolifts.com)

