



Presto LIFTS

worldwide material handling
and ergonomic solutions

PSL-22/20-E

PSL-22/27-E

Electric Skid Lifter



Installation, Operation and Service Manual

Model Number _____

Serial # _____

Date placed in service _____

IMPORTANT: READ CAREFULLY

BEFORE INSTALLING OR OPERATING LIFT

Part orders are subject to a \$50 minimum charge.

January 2012

Presto Lifts Limited Electric Skid Lifters Warranty Policy

Presto Lifts warrants the Electric Skid Lifter against defects in the welded structural frame and AC motors on lifts equipped with an AC power unit from faulty material and workmanship for a period of two (2) years from the date of invoice.

Presto Lifts warrants the Electric Skid Lifter against defects on the pumps, DC motors, cylinders and wiring harnesses from faulty material and workmanship for a period of one (1) year from the date of invoice.

All wear items such as batteries, wheels, motor brushes, seals, bearings, hydraulic hoses, all switches, battery chargers and forks have a limited warranty against defects in faulty material and workmanship for a ninety (90) day period from the date of invoice and 30 day limited warranty on labor. Please note that prior authorization from Presto Lifts is required on all warranty work.

There are no implied warranties of any kind, more specifically; there are no warranties of merchantability or fitness for any particular purpose. Presto Lifts' sole warranty shall be as set forth in this limited warranty. Presto Lifts will elect to repair or replace a defective component without charge, if any components should become defective within the limited warranty period. Proof of purchase is required for warranty. The charge for shipping the defective component is the responsibility of the buyer and must be accompanied with an RGA number. The shipping charge to return the component to the buyer is the responsibility of Presto Lifts, Inc.

This limited warranty does not cover labor expense for removal or reinstallation of components after thirty days. This limited warranty shall not cover, among other things: damages resulting from foreign matter or water, failure to provide reasonable and necessary maintenance, and if applicable, use of product while charger is plugged into an AC outlet, or failure to follow operating instructions. The limited warranty is not valid for damage resulting from negligence, accident, unreasonable use, abuse or misuse, exceeding data plate capacities or altering the product without Presto Lifts authorization.

Presto Lifts expressly disclaims and excludes any liability for consequential, incidental, indirect or punitive damages or financial loss to people or property resulting from any breach of warranty or the operation or failure of this product.

Presto Lifts makes no representation that this product complies with local, state, or federal safety/product standards codes. Should this product fail to comply in any way with those codes, it shall not be considered a defect of materials or workmanship. Presto Lifts shall not be held liable for any damages resulting from noncompliance. It is the dealer's responsibility to exercise this limited warranty. This limited warranty is provided to the original purchaser (defined as the original end user) and is nontransferable. This constitutes the complete and final agreement involving Presto Lifts and limited warranty obligations for products.

This manual was current at the time of printing. To obtain the latest, most updated version, please contact Presto Lifts Customer Service Department or go to our website: www.PrestoLifts.com -- you will find a complete list of current owner's manuals to print.

Contents

Limited Warranty.....	2
Introduction.....	4
Safety instructions	4
Product description.....	5
Placing into operation.....	6
Operating instructions.....	6
Troubleshooting.....	7
Battery & battery charger.....	7
Battery precautions.....	8
Figure 1. Lift Assembly	9
Figure 2. Electrical Circuit <i>Prior to December 2010</i>	10
Figure 3. Electrical Circuit <i>January 2011 to Present</i>	11
Figure 4. Steering Assembly.....	12
Figure 5. Cylinder	13
Figure 6. Frame Assembly.....	14
Figure 7. Power Unit.....	15
ORDERING REPLACEMENT PARTS.....	16
RESTOCKING POLICY.....	17

INTRODUCTION

Read and follow the instructions contained in this operating manual

Only trained, well-informed personnel, who have been instructed in accordance with this operation manual, may use or work on this machine.

Liability or guarantee is waived if:

- The instructions in this operating manual are not observed.
- The lift is operated, cleaned, or maintained incorrectly.
- Alterations to the functions are carried out without the consent of the manufacturer.
- Original spare parts are not used.

SAFETY INSTRUCTIONS

This chapter informs the user about residual dangers relating to the correct use of the products. It contains generally valid safety instructions which must be observed.

Safety instructions relating to specific actions or situations are listed prior to the respective action and/or description of the situation in the chapter.

PRINCIPLES

This product complies with state-of-the art technical standards and recognized safety regulations, but there are still dangers which may occur which must be considered.

Only operate the product in good condition and observing the information contained in the operating manual.

The operator is responsible for integrating

the product with as little risk as possible into his working environment. This obligation continues through every phase of the product's lifespan, beginning at the planning stage. Residual dangers are to be minimized.

Only trained, competent personnel who have been instructed using the operating manual and the product are permitted to work with the lift.

The operating manual must be understood (responsibility, checking).

DECLARATION

I have read this manual and, in particular, have taken note of the caution

Name (print)

Signature

Date

Name (print)

Signature

Date

PRODUCT DESCRIPTION

The PSL-22/20-E and PSL-22/27-E Electric Skid Lifter is designed on the basis of hand-operated high lift pallet truck. It is equipped with a battery, power unit, hose, and electrical control device.

It is featured by automatic raising and lowering. It can do a tremendous amount of work and increase worker efficiency. Meanwhile, it has kept the features of a hand lift truck, such as the application of material lifting and transporting when the fork is on its low position, and the use as a working table when the fork is at its highest position.

Those features make the Electric Skid Lifter a popular tool in the field of workshop and warehouse as a working table, or loading and unloading table for mini-truck and transporting tool.

Designated Use

- The lift is designed for lifting, lowering, and transportation of loads according to the specifications of the identification plate.
- The lift is to be used on level surfaces
- To move the lift between buildings, warehouses, etc:
 - The lift must be unloaded
 - The road surface must be solid and have good traction
- Travel routes must offer sufficient load-bearing capacity for the loaded truck.
- It is not permitted to use the lift in areas where there is an explosive atmosphere.
- The lift is not suitable for continuous use in coolers or freezers.



Warning!

The user is responsible for determining the actual load bearing capacity of the lift. This can depend on the user, the condition of both the floor and the lift, and the regularity of the maintenance intervals.

PLACING INTO OPERATION

Check for completeness of the construction and the condition of parts before the lift is placed into operation.

Delivery complete with battery

- The battery is full and charged
- The hydraulic tank is full
- The steering roller and the running rollers are equipped with bearings which do not require maintenance. All mast rollers are also maintenance-free.



Caution!

Pedestrian controlled industrial trucks may only be operated by persons who have been satisfactorily instructed in operating the truck and have proved their ability to operate the truck to the responsible representative of the operating company.

The first driving attempts should take place in open areas on level surfaces:

s

Recommendation:

The operator who is to maneuver the lift and is to control the lifting mechanism should be allowed to practice, when unloaded, until they can safely operate these functions

Only then should they undertake loading, transporting, and unloading.



Caution!

The driver is responsible for the lift during his working hours. He must not allow unauthorized personnel to use the lift.



Caution!

- Do not lift or pull people
- Do not put your hand or foot under the fork or on the moving surface of piston rod and mid-cylinder.
- Put the load on the center of the forks. Eccentric loading is strictly prohibited, and may damage the lift
- The safety valve in the power supply unit will automatically open when it is overloaded. Under such circumstance, do not push up-button. Otherwise that will reduce the lifetime of the power unit.
- To replace the hydraulic oil, the forks should be lowered to the lowest position. The oil used should be clean.

OPERATING INSTRUCTIONS

1. Handle is used for pulling and steering.
2. When the fork is lifted to its highest position, the lift should not be moved.
3. Push the Up-Button, the fork goes up. Stop pushing, the fork can stop at any position and won't slide down.
4. Push the Down-Button, the fork goes down. Stop pushing, the fork can stop at any position and won't slide down.
5. As a safety valve is set in the power unit, when a load of 1,000kgs is lifted (it's full capacity), only mid-cylinder can extend out fully, while the piston rod cannot extract out to prevent overload.

Troubleshooting

Problem	Cause	Remedy
Fork does not lift up when pushing up button	<ul style="list-style-type: none"> • Switch is out of order • Fuse is broken • magnetic switch is out of order • Oil level is too low 	<ul style="list-style-type: none"> • Check switch • Replace fuse • Check magnetic switch • Fill oil
Fork down not lower when pushing down button	<ul style="list-style-type: none"> • Switch is broken • Fuse is broken • Magnetic switch is out of order • Object blocking descent 	<ul style="list-style-type: none"> • Check switch • Replace fuse • Check magnetic switch • Check & remove object
Fork does not lift to full height Motor does not work	<ul style="list-style-type: none"> • Not enough oil • Motor broken • Terminals and inserters loose • Battery worn out 	<ul style="list-style-type: none"> • Check & add oil • Check motor brush • Check terminals & inserters • Recharge battery
Battery too weak	<ul style="list-style-type: none"> • Recharging time too short • Battery out of order 	<ul style="list-style-type: none"> • Charge longer • Replace battery
Oil leakage from piston rod & mid-cylinder	<ul style="list-style-type: none"> • Oil seals are broken 	<ul style="list-style-type: none"> • Replace oil seals
Unsteady when in highest position	<ul style="list-style-type: none"> • The ground is not flat or even • Centrifugal axle is left from the ground 	<ul style="list-style-type: none"> • Move the lift to flat surface • Adjust centrifugal axle to touch ground

BATTERY & BATTERY CHARGER

The batteries and battery charger are packed inside the battery pack. Follow the operating procedures to charge battery:

1. Turn switch key counter clockwise to turn off the power supply.
2. Disconnect the battery cable connector from compartment of the stacker and then fully engage it to the compartment of the battery charger.
3. Before connecting the battery charger to the local power supply, check and ensure that the voltage of both is the same.
4. Connect the AC extension cord from the charger into the outlet of local power supply. This will automatically turn the charger on, and it will run at a rate commensurate with

the requirements of the batteries. The charger will automatically control the charging procedure and when the batteries are fully charged, the charger will only supply enough current to maintain battery's charge

The warranty becomes invalid when the operating instructions are not adhered to, when repairs are carried out without using original spare parts or when modifications are not authorized.

Battery Precautions



- Observe operating instructions and display clearly in holding area.
- Work on batteries only under instruction of specially trained staff.



- Wear protective glasses and clothing when working on the batteries
- Observe the accident prevention regulations.



- NO SMOKING around battery
- Do not expose battery to open flames or sparks, at risk of explosion and fire



- If eyes or hands come in contact with acid, rinse immediately with clear water.
- Seek medical attention immediately if contact occurs.



- Avoid risk of explosion, fire and short-circuiting.
- CAUTION! Metal parts of battery are live - do not rest any foreign objects or tools on the battery.



- Electrolyte is very corrosive!



- Do not tilt the battery
- Use only permitted lifting & transporting device, e.g. raising harness
- Lifting hooks must not cause any damage to cells, connectors, or connection cables



- Spent batteries with this symbol are recyclable and must be taken to the appropriate recycling point
- Spent batteries which are not recyclable must be disposed of according to hazardous waste regulations

Figure 1. Lift Assembly

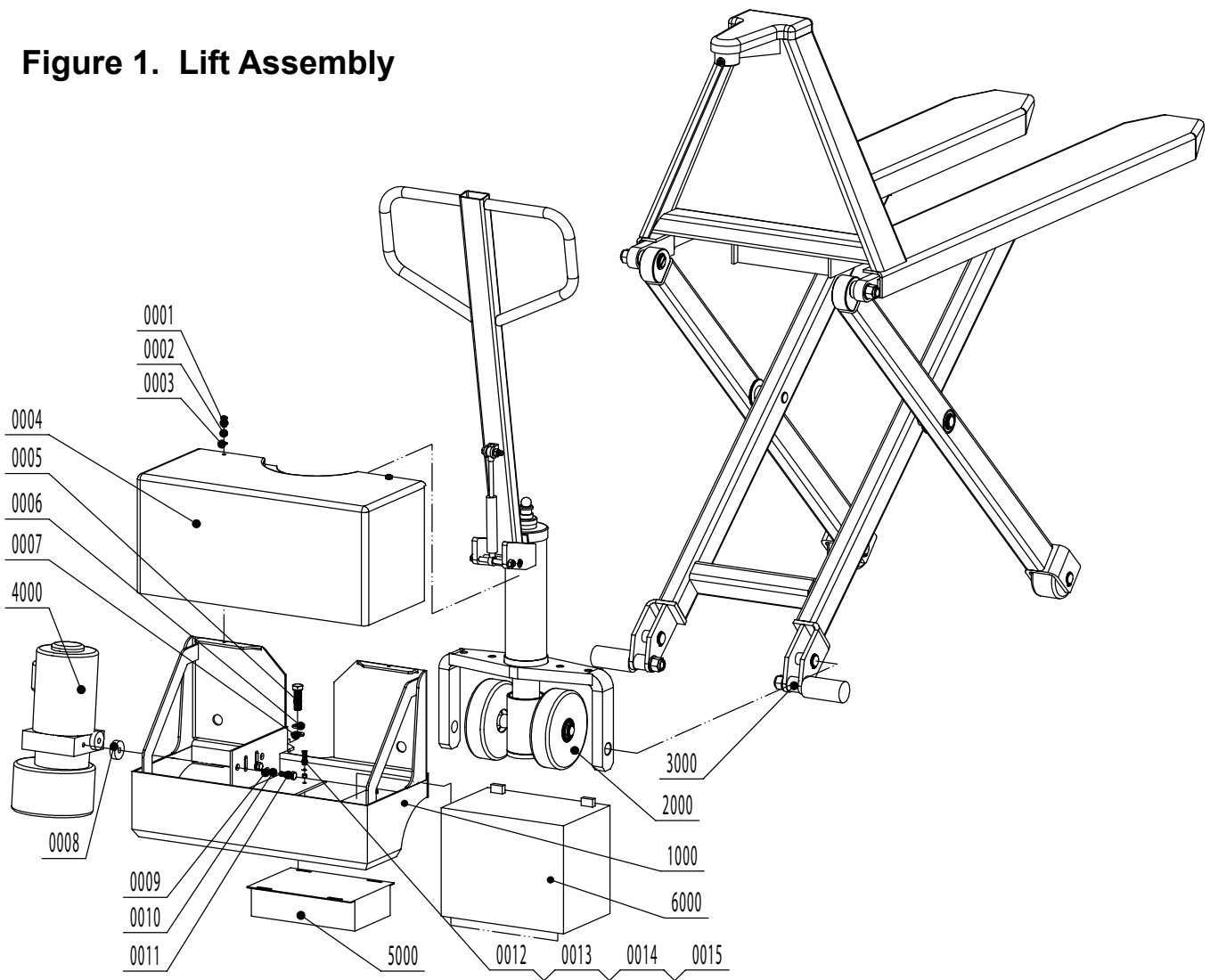

Item	Description	Qty	Item	Description	Qty
1000	Control case	1	0005	Bolt M12 x 40	4
2000	Steering assembly	1	0006	Spring washer 12	4
3000	Lift frame assembly	1	0006	Flat washer 12	4
4000	Power unit	1	0008	Block metal	2
5000	Battery charger 12V/10A	1	0009	Flat washer 8	2
6000	Battery 12V/70Ah	1	0010	Spring washer 8	2
0001	Bolt M6 x 16	2	0011	Bolt M8 x 25	2
0002	Washer 6	2	0012	Bolt M5 x 15	2
0003	Flat washer 6	2	0013	Nut M5	2
0004	Cover 1		0014	Spring washer 5	2
			0015	Flat washer 5	2

Prior to December 2010

Figure 2. Electrical Circuit

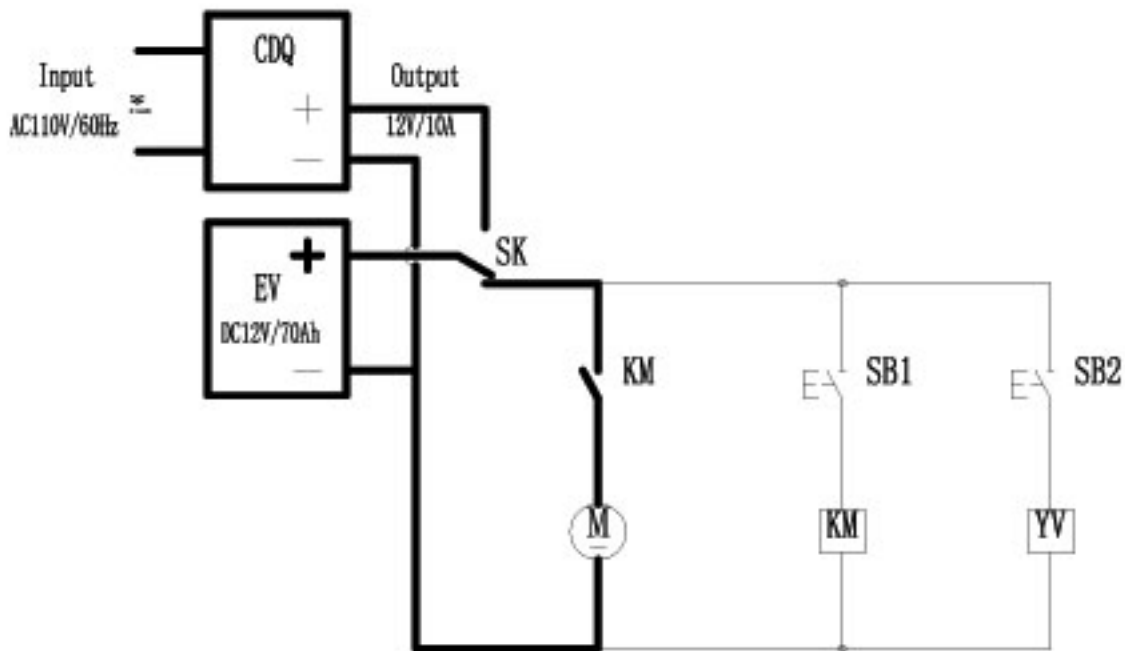

Item	Description
5001	Wire (Control system)
5002	Wire (Main)
5003	Solenoid w/coil
5004	Hydraulic moto
5005	Start switch
2019-1	Down button
2019-1	Up button
2020	On/Off switch
5000	Charger
6000	Battery

Figure 3. Steering Assembly

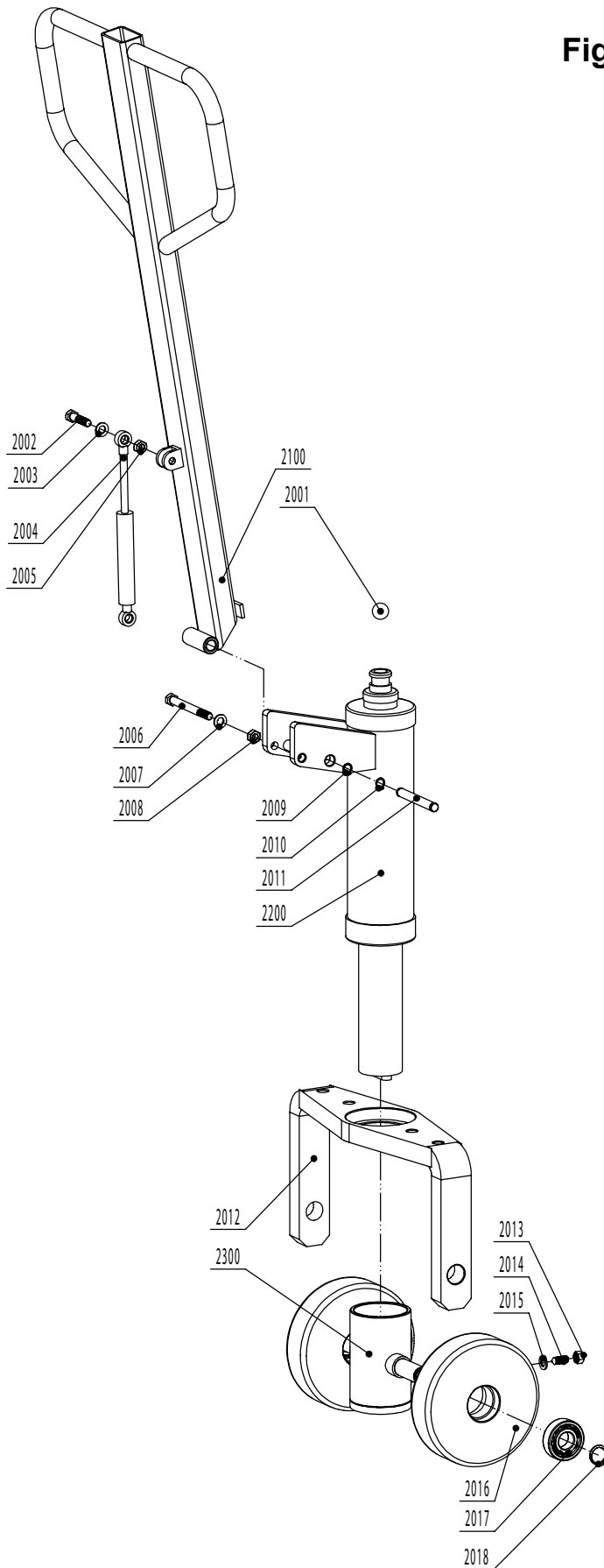

Item	Description	Qty
2100	Handle	1
2200	Cylinder	1
2300	Wheel yoke	1
2001	Steel ball 19	1
2002	Bolt M8 x 35	1
2003	Flat washer 8	1
2004	Air spring	1
2005	Lock nut M8	1
2006	Bolt M8 x 85	1
2007	Flat washer 8	1
2008	Lock nut M8	1
2009	Spring washer 10	1
2010	Spring washer 10	1
2011	Pin 1	1
2012	Cylinder yoke	1
2013	Lock nut M8	1
2014	Lock bolt M8 x 16	1
2015	Flat washer 8	1
2016	Rear wheel	2
2017	Bearing 6204	4
2018	Spring washer 20	2

Figure 4. Cylinder

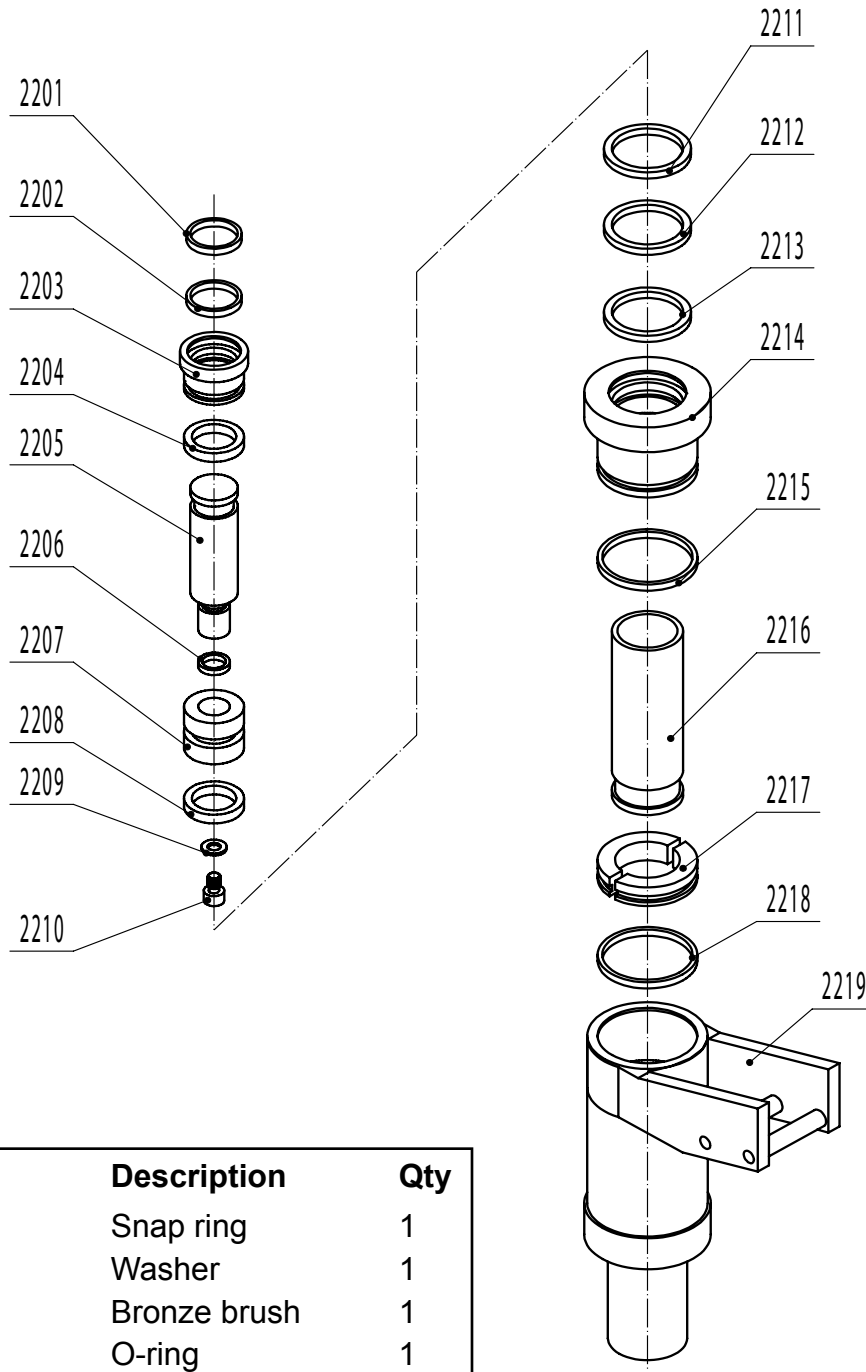

Item	Description	Qty
2201	Snap ring	1
2202	Washer	1
2203	Bronze brush	1
2204	O-ring	1
2205	Piston rod	1
2206	O-ring	1
2207	Piston	1
2208	Y-ring	1
2209	Bronze brush	1
2210	Screw	1

Item	Description	Qty
2211	Scraper ring	1
2212	O-ring	1
2213	Y-ring	1
2214	Cylinder head	1
2215	O-ring	1
2216	Cylinder	1
2217	Copper piston	1
2218	Snap ring	1
2219	Pump housing	1

Figure 5. Frame Assembly

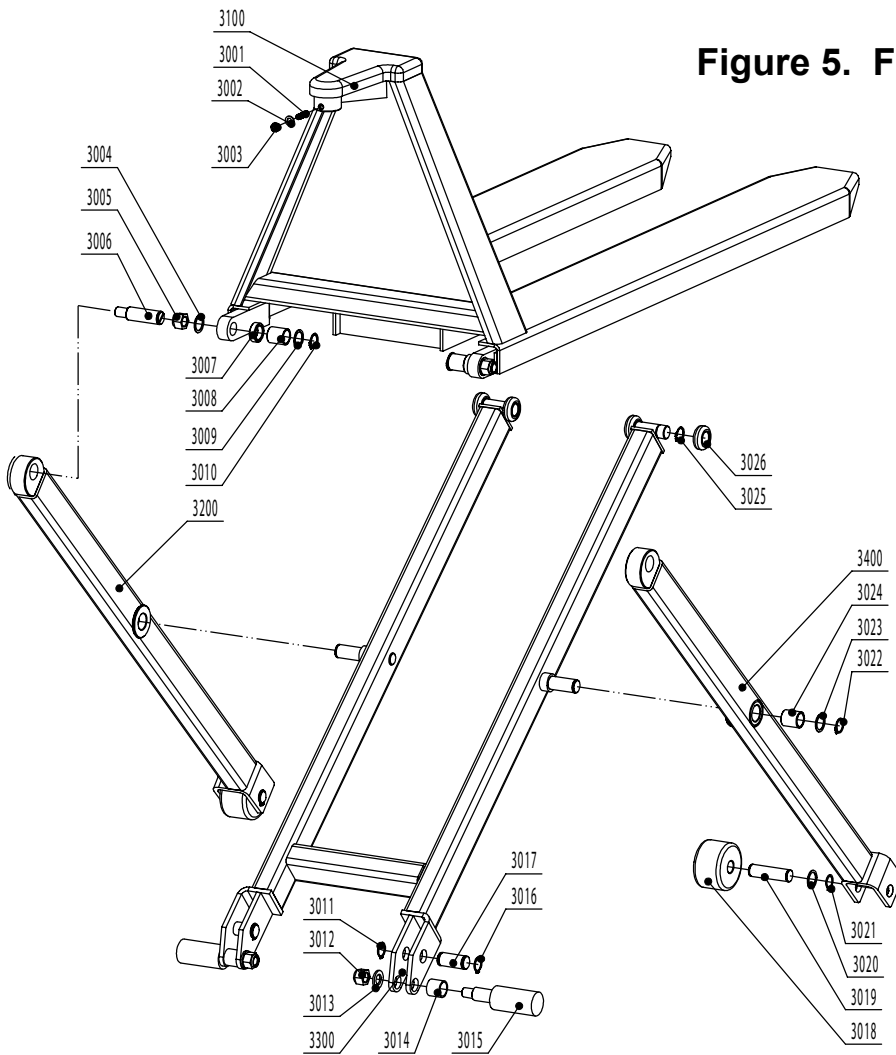

Item	Description	Qty	Item	Description	Qty
3100	Fork assembly	1	3012	Lock nut M16	2
3200	Right scissor	1	3013	Flat washer 16	2
3300	Inner scissor	1	3014	Spacer I	2
3400	Left scissor	1	3015	Centrifugal axle	2
3301	Screw M8 x 30	1	3016	Spring washer 22	2
3302	Flat washer 8	1	3017	Pin III	2
3303	Lock nut M8	1	3018	Front wheel 75	2
3304	Flat washer 16	2	3019	Wheel axle	2
3305	Lock nut M16	2	3020	Washer 22	2
3306	Pin II	2	3021	Spring washer 20	2
3307	Spacer	2	3022	Spring washer 22	2
3308	Copper sleeve 2227	2	3023	Washer 22	2
3309	Washer 22	2	3024	Copper sleeve 2227	2
3010	Spring washer 22	2	3025	Spring washer 22	4
3011	Spring washer 22	2	3026	Wheel 40	4

Figure 6. Power Unit

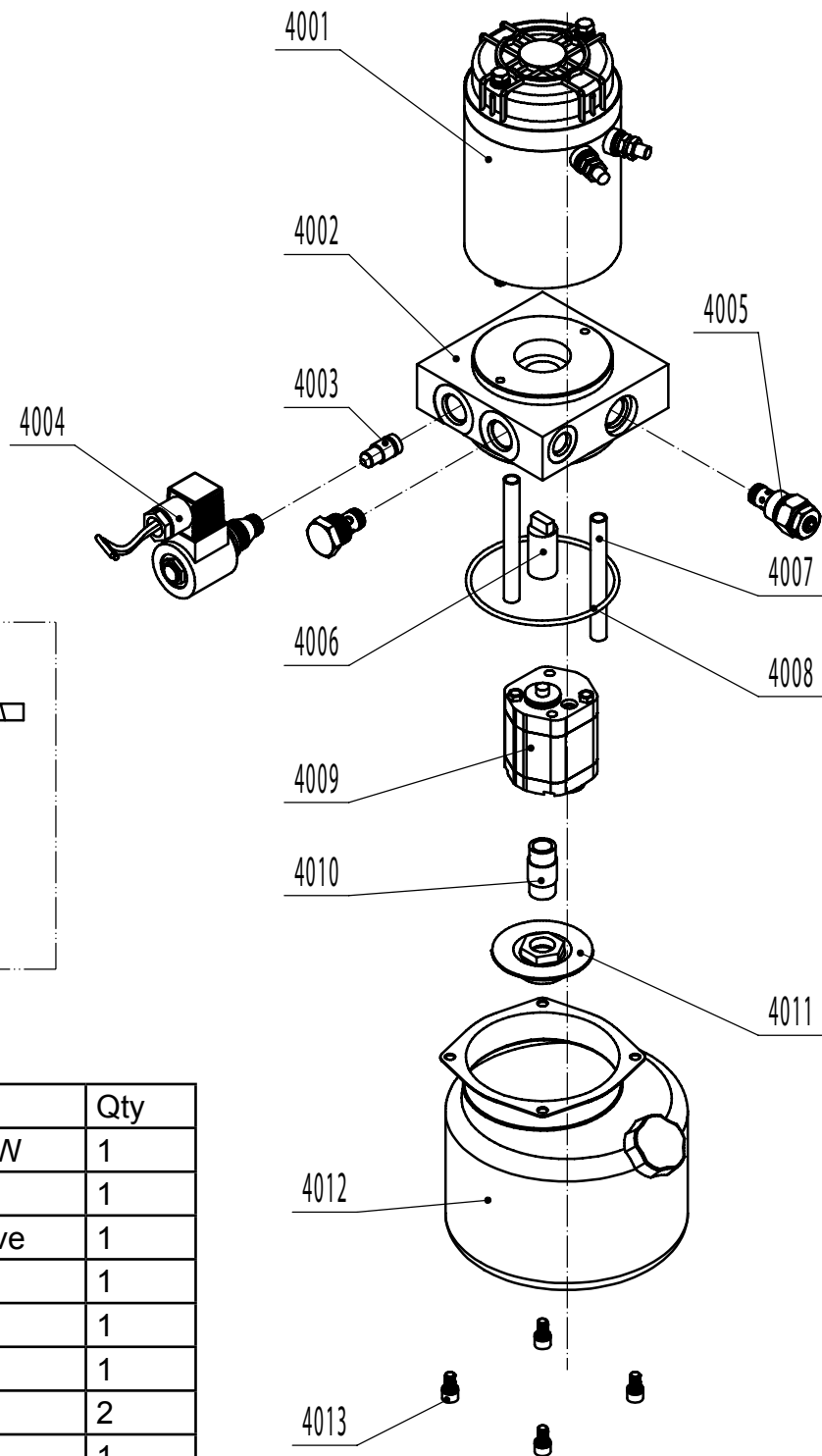
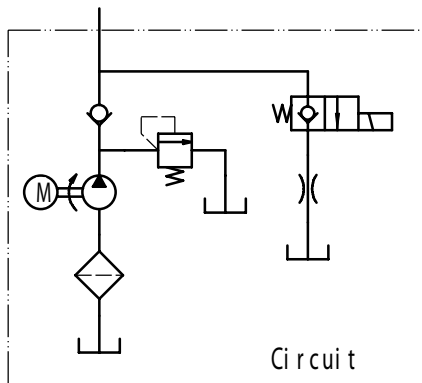

Item	Description	Qty
4001	Motor 12V/1.2KW	1
4002	Block	1
4003	Flow control valve	1
4004	Solenoid valve	1
4005	Relief valve	1
4006	Connect pipe	1
4007	Return tube	2
4008	O-ring 95 x 3.1	1
4009	Gear pump 0.4m ³ /r	1
4010	Suction	1
4011	Filter	1
4012	Tank	1
4013	Bolt M6 x 12	4

Ordering Replacement Parts

Presto Lifts has carefully chosen the components in your unit to be the best available for the purpose. Replacement parts should be identical to the original equipment. Presto Lifts will not be responsible for equipment failures resulting from the use of incorrect replacement parts or from unauthorized modifications to the unit.

Presto Lifts can supply all replacement parts for your lift. With your order, please include the model number and the serial number of the unit. You can find these numbers on the name plate. This plate is located within the cabinet, or the angle iron cylinder cross support.

To order replacement parts, please call the Presto Parts Department. Parts are shipped subject to the following terms:

- FOB factory
- Returns only with the approval of our Parts Department.
- Credit cards preferred (except parts covered by warranty).
- Freight collect for truck (except parts covered by warranty).
- Freight - prepaid and invoice for small parcel shipments (except parts covered by warranty).

Parts replaced under warranty are on a “charge-credit” basis. We will invoice you when we ship the replacement part, then credit you when you return the worn or damaged part.

Presto Lifts Parts Department
21 Park Street, Attleboro, MA 02703

Telephone: 800-343-9322

FAX: 888-788-6496

Email: Service@PrestoLifts.com

www.PrestoLifts.com

PARTS

Standard parts may be returned with a 20% restocking fee. Modified or custom-engineered parts are not returnable. Unfortunately, due to potentially concealed damage, all sales of electrical assemblies are final.

QUALITY ISSUES

Should you feel there is a quality problem, please contact the seller to ask questions and gather information on how to rectify the issue. Presto Lift Inc. reserves the right to determine potential credits, as a result of factory defects, based on its inspection of the merchandise.

GENERAL

All products shipped from our factory have passed Quality Assurance inspection and testing. The carrier of choice has signed for, and accepted the product in new working condition. The customer should inspect to ensure it is not received damaged, has no concealed damage or is not incomplete. Parts orders are determined to be complete based upon Presto Lift, Inc. inspection sheets and carrier shipping weights.

RETURN GOODS AUTHORIZATION POLICY

Presto Lifts provides the Return Goods Authorization (RGA) Policy, for specific models, as a courtesy to our distributors in the event they do not receive what they ordered. If a customer wishes to return a Presto Lifts product, please contact the Customer Service Department and request an RGA number. This request must be made on or before the fifteenth calendar day following the date of Presto Lifts' invoice for the merchandise. Not all units are returnable. Quantity orders and special designs cannot be returned under any circumstances. Presto Customer Service reserves the right for final judgment on all product returns.

The RGA number must appear on the outside of any packaging material for a return to be accepted and processed by Presto Lifts. Customers shipping returns from the Continental US, Canada, or Mexico have thirty (30) days from date of RGA issue to have the product arrive at Presto Lifts' facility. All merchandise must arrive Free on Board at Presto Lifts' facility or the shipment will be refused and returned to the sender. All credits are issued less restocking and refurbishing charges, regardless if the merchandise was damaged in transit.

Return addresses: please refer to your RMA for the address to which your product should be returned.

Presto Lift Inc.
715 Highway 77
Manila, Arkansas 72442

Telephone: 800-343-9322
Fax: 888-788-6496

MANY NEEDS REQUIRE MANY OPTIONS...

Presto LIFTS



LET PRESTO MEET THOSE NEEDS!

Call Presto Sales
for stock or
customized lift inquiries:
800-343-9322

Email: sales@prestolifts.com

